

**OPERATOR'S, UNIT, DIRECT SUPPORT, AND,
GENERAL SUPPORT MAINTENANCE MANUAL**

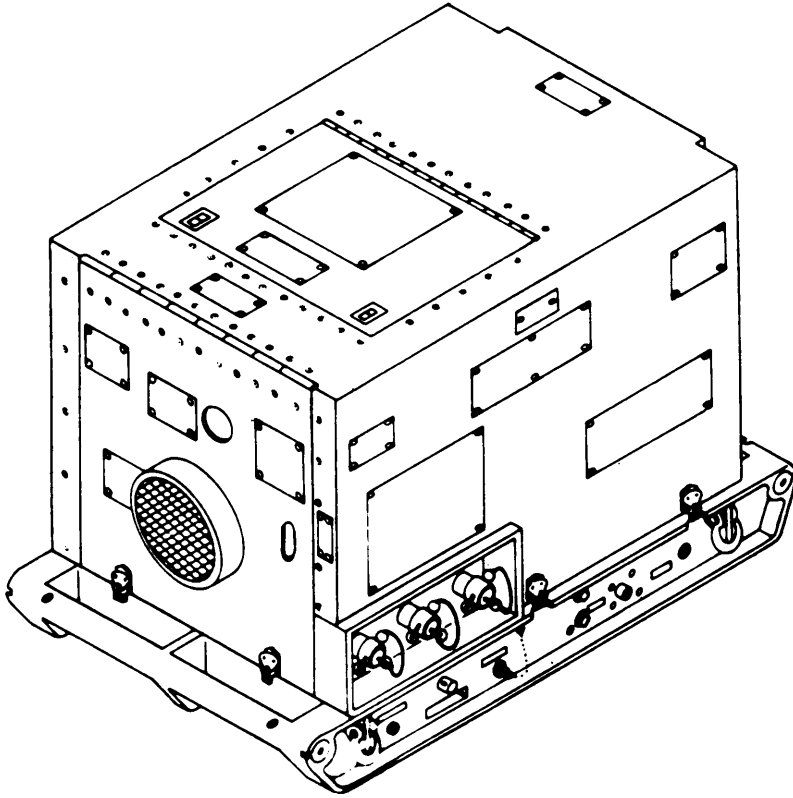

OPERATOR
PREVENTIVE
MAINTENANCE 2-3

OPERATION
UNDER UNUSUAL
CONDITIONS 2-31

LUBRICATION
INSTRUCTIONS 3-1

UNIT
PREVENTIVE
MAINTENANCE 4-5

UNIT
TROUBLESHOOTING 4-11

UNIT
MAINTENANCE
PROCEDURES 4-13

DIRECT SUPPORT
TROUBLESHOOTING 5-1

DIRECT SUPPORT
MAINTENANCE 5-3

GENERAL
SUPPORT
MAINTENANCE 6-1

SMALL MOBILE WATER CHILLER
Model LCW 2685 (4130-01-131-2685)
Model LCC 2685 (4130-01-315-7583)

*This manual supersedes TM 5-4130-237-14, dated 11 December 1985, including changes 1 through 3; change 4 was superseded by TM 10-41 30-239-14, dated 14 November 1991.

Approved for public release; distribution is unlimited

HEADQUARTERS, DEPARTMENT OF THE ARMY

12 JUNE 1992

WARNING

HIGH VOLTAGE

To prevent electric shock, always disconnect power cable from 12/24 VOLT INPUT FOR STARTING connection before performing maintenance.

WARNING

HEARING DAMAGE

Hearing loss may result from operating water chiller without proper hearing protection. Always wear hearing protection when within 4 feet (1.2 meters) of running water chiller.

WARNING

FUEL IS FLAMMABLE

To prevent possible fire or explosion, DO NOT bring sparks or open flames near fuel.

WARNING

DANGEROUS CHEMICALS

- Calcium hypochlorite can cause serious injury if not handled properly. Heed all safety measures below.
- If calcium hypochlorite comes into contact with skin or eyes, flush right away with water. Get medical help.
- Store calcium hypochlorite in a cool, dry place. Keep container closed.
- Mix only in accordance with directions for use.
- DO NOT allow calcium hypochlorite to mix with any other materials, such as fuels, oils, paint products, or ammonia. This may cause fire or hazardous gases.

FOR FIRST AID, SEE FM 21-11.

TECHNICAL MANUAL

No. 10-4130-237-14

HEADQUARTERS
DEPARTMENT OF THE ARMY
WASHINGTON, D.C., 12 JUNE 1992

**Operator's, Unit, Direct Support,
and General Support Maintenance Manual**

SMALL MOBILE WATER CHILLER
(4130-01-131-2685)
(4130-01-315-7583)

Approved for public release; distribution is unlimited.

REPORTING ERRORS AND RECOMMENDING IMPROVEMENTS

You can help improve this manual. If you find any mistake or if you know of away to improve the procedures, please let us know. Mail your letter, DA Form 2028 (Recommended Changes to Publications and Blank Forms), or DA Form 2028-2 located in the back of this manual direct to: Commander, U.S. Army Troop Support Command, ATTN: AMSTR-MMTS, 4300 Goodfellow Boulevard, St. Louis, MO 63120-1798. A reply will be furnished directly to you.

Table of Contents

	Page
CHAPTER 1 INTRODUCTION	1-1
Section I General Information	1-1
Section II Equipment Description and Data	1-1
Section III Principles of Operation	1-4
CHAPTER 2 OPERATING INSTRUCTIONS	2-1
Section I Description and Use of Operator's Controls and Indicators	2-1
Section II Operator Preventive Maintenance Checks and Services (PMCS)	2-3
Section III Operation Under Usual Conditions	2-15
Section IV Operation Under Unusual Conditions	2-30
CHAPTER 3 OPERATOR MAINTENANCE	3-1
Section I Lubrication Instructions	3-1
Section II Troubleshooting	3-1
Section III Maintenance Procedures	3-2

*This manual supersedes TM 5-4130-237-14 dated 11 December 1985, including changes 1 through 3; change 4 is superseded by TM 10-4130-239-14, dated 14 November 1991.

		Page
CHAPTER 4	UNIT MAINTENANCE	4 - 1
Section I	Repair Parts; Special Tools; Test Measurement, and Diagnostic Equipment (TMDE); and Support Equipment	4 - 2
Section II	Service Upon Receipt	4 - 3
Section III	Unit Preventive Maintenance Checks and Services (PMCS)	4-4
Section IV	Unit Troubleshooting	4-10
Section V	Unit Maintenance Procedures	4-13
Section VI	Preparation for Storage or Shipment	4-102
CHAPTER 5	DIRECT SUPPORT MAINTENANCE	5 - 1
Section I	Direct Support Troubleshooting	5 - 1
Section II	Direct Support Maintenance Procedures	5 - 3
CHAPTER 6	GENERAL SUPPORT MAINTENANCE	6 - 1
APPENDIX A	REFERENCES	A-1
APPENDIX B	MAINTENANCE ALLOCATION CHART	B - 1
APPENDIX C	COMPONENTS OF END ITEM AND BASIC ISSUE ITEMS LISTS	C-1
APPENDIX D	ADDITIONAL AUTHORIZATION LIST ITEMS	D-1
APPENDIX E	EXPENDABLE/DURABLE SUPPLIES AND MATERIALS LIST	E - 1
APPENDIX F	ILLUSTRATED LIST OF MANUFACTURED ITEMS	F - 1
	INDEX	Index-1

HOW TO USE THIS MANUAL

This manual is designed to help you operate and maintain the Small Mobile Water Chiller. The front cover table of contents is provided for quick reference to important information. There is also an index located in the final pages for use in locating specific items of information.

Measurements in the manual are given in both US standard and metric units. A metric to US standard conversion chart can be found on the inside back cover.

Read all preliminary information found at the beginning of each task. It has important information and safety instructions you must follow before beginning the task.

Warning pages are located in the front of this manual. You should read the warnings before operating or doing maintenance on the equipment.

A subject index appears at the beginning of each chapter listing sections that are included in that chapter. A more specific index is located at the beginning of each section to help you find the exact paragraph you're looking for.

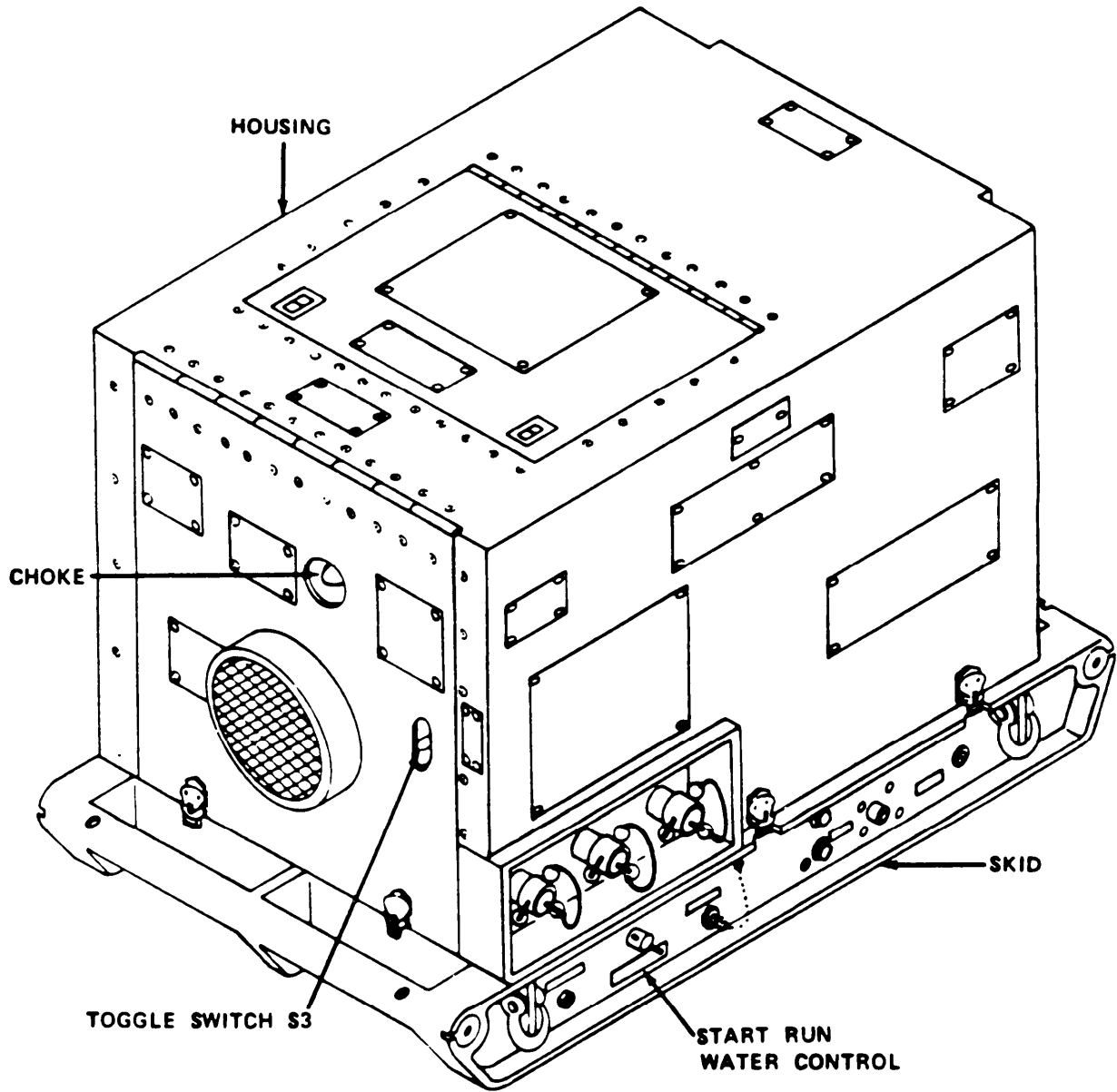

CHAPTER 1 INTRODUCTION

Section I GENERAL INFORMATION

1-1. SCOPE. This manual contains operating instructions and operator's, organizational, direct support, and general support maintenance for the Small Mobile Water Chiller. The water chiller cools intake water to 60° F (16° C) and delivers it at 40 gallons (151 liters) per hour.

1-2. MAINTENANCE FORMS, RECORDS, AND REPORTS. Department of the Army forms and procedures used for equipment maintenance will be those prescribed by DA Pam 738-750, The Army Maintenance Management System (TAMMS).

1-3. DESTRUCTION OF ARMY MATERIEL TO PREVENT ENEMY USE. To prevent enemy use of the water chiller, follow instructions contained in TM 750-244-3.

1-4. PREPARATION FOR STORAGE OR SHIPMENT. See paragraph 4-38 for instructions on preparation for storage or shipment.

1-5. REPORTING EQUIPMENT IMPROVEMENT RECOMMENDATIONS (EIR). If your water chiller needs improvement, let us know. Send us an EIR. You, the user, are the only one who can tell us what you don't like about your equipment. Let us know why you don't like the design. Put it on an SF 368 (Quality Deficiency Report). Mail it to us at: Commander, U.S. Army Troop Support Command, ATTN: AMSTR-MOF, 4300 Goodfellow Boulevard, St. Louis, MO 63120-1798. We'll send you a reply.

Section II. EQUIPMENT DESCRIPTION AND DATA

1-6. EQUIPMENT CHARACTERISTICS, CAPABILITIES, AND FEATURES

a. Characteristics

- Powered by air-cooled, gasoline-driven engine
- Used on M149 series trailer

1-6. EQUIPMENT CHARACTERISTICS, CAPABILITIES, AND FEATURES (CONT)

- Compatible with 400-gallon (1514-liter) water trailer, 250-gallon (946-liter) and 500-gallon (1893-liter) fabric drums, and 5-gallon (19-liter) cans

b. Capabilities and Features

- Cools intake water of 120°F (49°C) to about 60°F (16°C)
- Delivers water at rate of 40 gallons (151 liters) per hour
- Skid-mounted for ease of transport; four-man portable for short distances
- Started with rope or with a 12-volt power source

1-7. LOCATION AND DESCRIPTION OF MAJOR COMPONENTS

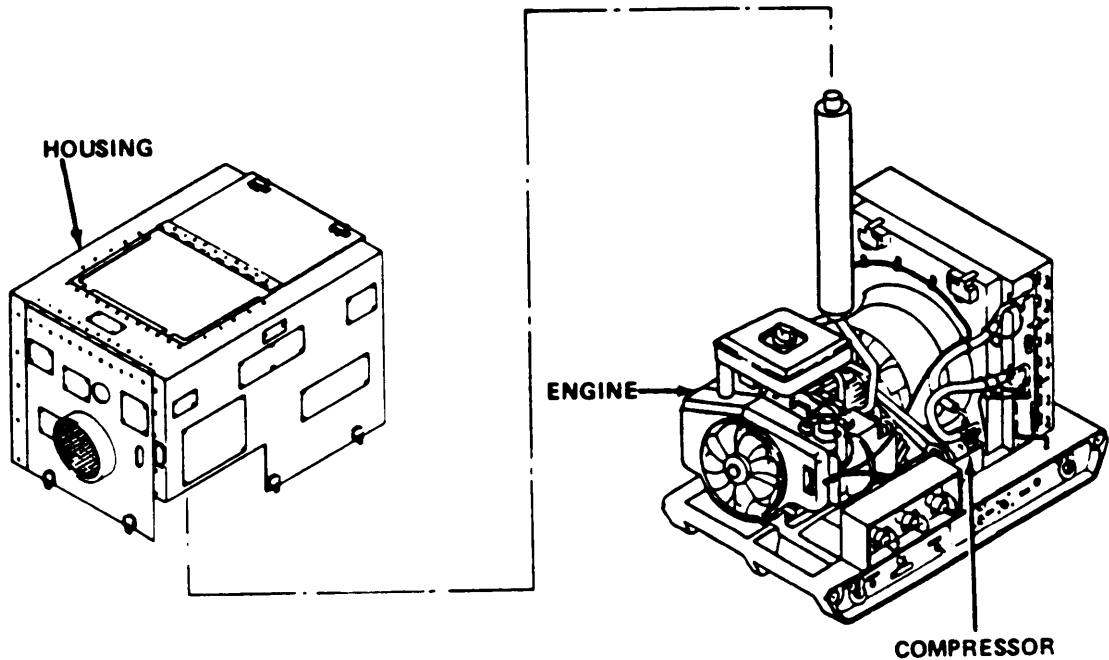

HOUSING. Protects water chiller from damage. Covers moving parts.

ENGINE. Powers belts which drive the compressor and water pump.

COMPRESSOR. Compresses and circulates refrigerant.

1-7. LOCATION AND DESCRIPTION OF MAJOR COMPONENTS (CONT)

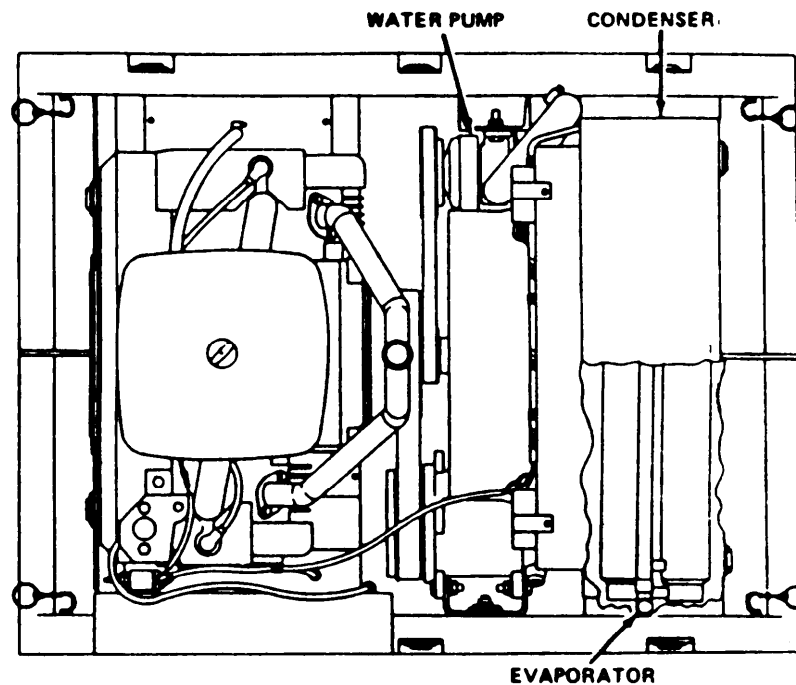

CONDENSER. Changes gas refrigerant to liquid.

WATER PUMP. Pumps water through evaporator.

EVAPORATOR. Absorbs heat from water.

1-8. DIFFERENCES BETWEEN MODELS.

- a. Data Plates. Some models of the water chiller have slightly different data plates. If any data plates are damaged or missing, replace them **ONLY** with the ones listed in this manual. (See paragraph 4-10).
- b. Carburetor. There are two different carburetors used with the water chiller. Differences in repair or adjustment are listed in the appropriate maintenance procedures.
- c. Compressor Drive Pulleys. Some models of the water chiller have a compressor drive pulley assembly with two mounting screws. When replacing this assembly, use a new compressor drive pulley assembly and a new compressor mounting bracket.

1-8. DIFFERENCES BETWEEN MODELS (CONT)

d. Centrifugal Clutch. Some water chillers (designated as Model LCC-2685) are equipped with a centrifugal clutch and matching compressor pulley to reduce starting load and delay period between starts. Differences in repair or adjustment are listed in the appropriate maintenance procedures.

1-9. MOUNTING KITS. There are two different mounting kits with the water chiller. Differences in repair are listed in the appropriate maintenance procedure.

1-10. EQUIPMENT DATA

Water Chiller

Height, cover	20in. (51cm)
Width, cover	25in. (64cm)
Length, cover	29in. (74cm)
Height, overall	24in. (61cm)
Width, overall	26in. (66cm)
Length, overall	34in. (86cm)
Gross weight	315 lb (143 kg)

Engine

Type	2-cylinder
Model series	422435
Horsepower	1 8
Weight	106 lb (48 kg)
Spark plug (resistor type)	gap 0.030 in. (0.76 mm)
Crankcase oil capacity	3.5 pt (1.7 liters)

Special Purpose Kits

Support kit	
Gross weight	47 lb (21 kg)
Trailer mounting kit	
Gross weight (less packing)	69 lb (31 kg)

Shipping Container

Length	41 in. (104 cm)
Width	32 in. (81 cm)
Height	45 in. (114 cm)
Shipping weight	679 lb (308 kg)

Section III. PRINCIPLES OF OPERATION

1-11. GENERAL OPERATION. The water chiller consists of an air-cooled, gasoline engine, a refrigeration system, and a water system. The refrigeration system processes refrigerant through an evaporator. The water system circulates water through the evaporator which absorbs the water's heat. The engine turns drivebelts. These belts drive the compressor and water pump.

1-12. MAJOR SYSTEMS

a. Engine. The water chiller engine has two cylinders. The engine drives a fan mounted on the driveshaft. The fan air-cools the condenser. Drivebelts on the fan hub drive the compressor and the water pump. The speed of the engine is preset and governor controlled.

b. Refrigeration System. Processes refrigerant which cools the water.

(1) Compressor. Compresses and circulates refrigerant through the system.

(2) Condenser Coil. Air-cools gas refrigerant and changes it to liquid at high pressure.

(3) Fan. Draws outside air through the condenser coil to cool compressed refrigerant.

(4) Evaporator. Uses refrigerant to chill water.

c. Water System. Water pump draws warm water from water source. It circulates water through the evaporator where the heat in the water is absorbed.

CHAPTER 2
OPERATING INSTRUCTIONS

Section I. DESCRIPTION AND USE OF OPERATOR'S
CONTROLS AND INDICATORS

2-1. OPERATOR'S CONTROLS AND INDICATORS

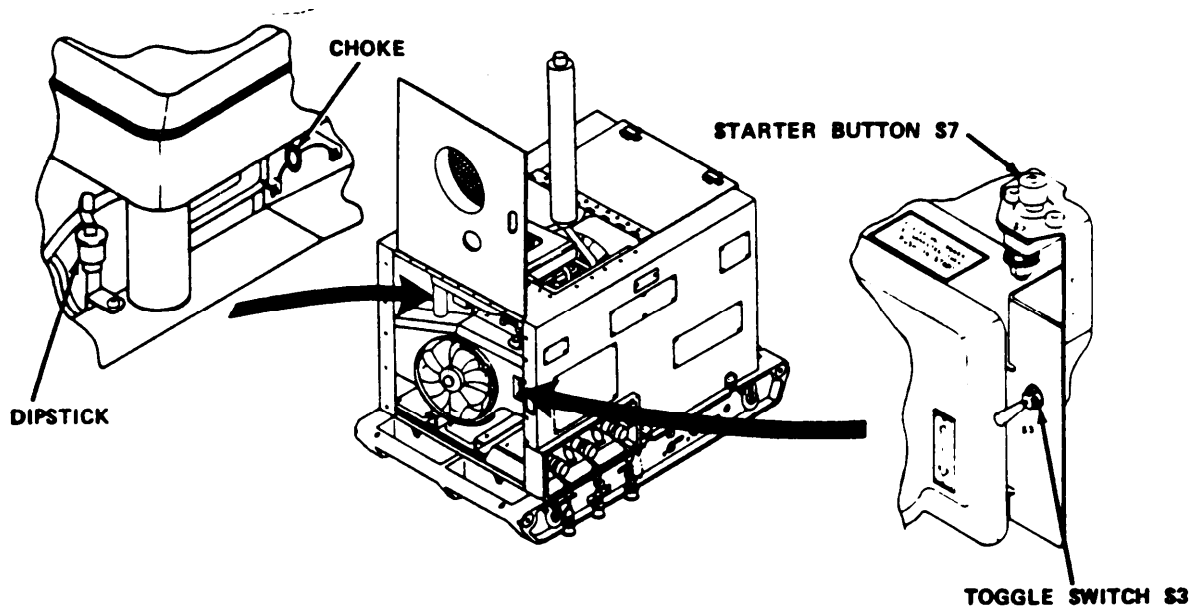

Control or Indicator	Function
Dipstick	Used to check oil level.
Choke	Pulled out to engage. Increases gas flow to engine.
Starter Button S7	Engages starter when pressed. Disengages starter when released.
Toggle Switch S3	Used to place equipment in STOP, RUN, or START mode.

2-1. OPERATOR'S CONTROLS AND INDICATORS (CONT)

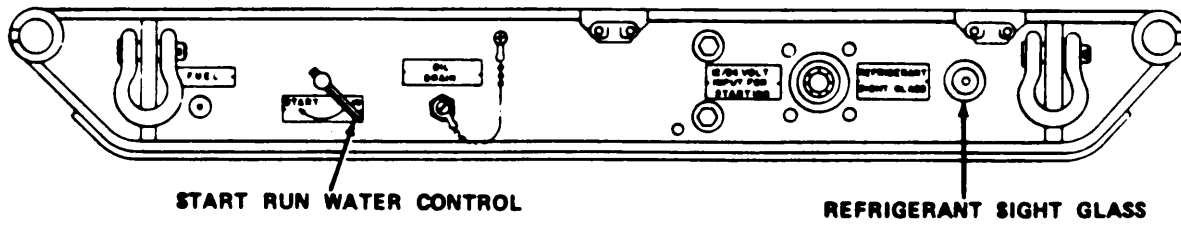

Control or Indicator	Function
START RUN Water Control	Placed in START position for starting and in RUN position for circulating water.
REFRIGERANT SIGHT GLASS	<p>Shows amount of moisture in refrigerant and status of refrigerant charge as follows:</p> <ul style="list-style-type: none"> Dark green center – no moisture Light green center – acceptable moisture content Yellow center – too much moisture Milky white or bubbly liquid – low refrigerant charge Clear, bubble-free refrigerant – fully charged system

Section II. PREVENTIVE MAINTENANCE CHECKS AND SERVICES (PMCS)

2-2. GENERAL

Preventive Maintenance Checks and Services (PMCS) means systematic caring, inspecting, and servicing of equipment to keep it in good condition and to prevent breakdowns. As the water chiller's operator, your mission is to:

- a. Be sure to perform your PMCS each time you operate the water chiller. Always do your PMCS in the same order, so it gets to be a habit. Once you've had some practice, you'll quickly spot anything wrong.
- b. Do your BEFORE (B) PMCS just before you operate the water chiller. Pay attention to WARNINGS, CAUTIONS, and NOTES.
- c. Do your DURING (D) PMCS while you operate the water chiller. During operation means to monitor the water chiller and its related components while it is actually being operated. Pay attention to WARNINGS, CAUTIONS, and NOTES.
- d. Do your AFTER (A) PMCS right after operating the water chiller. Pay attention to WARNINGS, CAUTIONS, and NOTES.
- e. Do your WEEKLY (W) PMCS once a week.
- f. Do your MONTHLY (M) PMCS once a month.
- g. Use DA Form 2404 (Equipment Inspection and Maintenance Worksheet) to record any faults that you discover before, during, or after operation, unless you can fix them. You DO NOT need to record faults that you fix.
- h. Be prepared to assist organizational maintenance when they lubricate the water chiller. Perform (any other services when required by organizational maintenance.

2-3. PMCS PROCEDURES

- a. Your Preventive Maintenance Checks and Services, Table 2-1, lists inspections and care required to keep your water chiller in good operating condition. It is set up so you can make your BEFORE (B) OPERATION checks as you walk around the water chiller.
- b. The "INTERVAL" column of Table 2-1 tells you when to do a certain check or service.
- c. The "PROCEDURE" column of Table 2-1 tells you how to do required checks and services. Carefully follow these instructions. If you do not have tools, or if the procedure tells you to, notify your supervisor.

NOTE

Terms "ready/available" and "mission capable" refer to same status: Equipment is on hand and ready to perform its combat missions. (See DA Pam 738-750)

- d. The "EQUIPMENT IS NOT READY/AVAILABLE IF:" column in Table 2-1 tells you when your water chiller is nonmission capable and why the water chiller cannot be used.
- e. If the water chiller does not perform as required, refer to Chapter 3, Section H, Troubleshooting.
- f. If anything looks wrong and you can't fix it, write on your DA Form 2404. IMMEDIATELY, report it to your supervisor.

g. When you do your PMCS, you will always need a rag or two. Following are checks that are common to the entire water chiller:

- (1) **Keep It Clean.** Dirt, grease, oil, and debris only get in the way and may cover up a serious problem. Clean as you work and as needed. Use dry cleaning solvent (SD-2) on all metal surfaces. Use soap and water when you clean rubber or plastic material. Upholstery can be cleaned with soap and water and a clean, damp cloth.
- (2) **Rust and Corrosion.** Check water chiller and frame for rust and corrosion. If any bare metal or corrosion exists, clean, and apply a thin coat of oil. Report it to your supervisor.
- (3) **Bolts, Nuts, and Screws.** Check them all for obvious looseness, missing, bent, or broken condition. You can't try them all with a tool, but look for chipped paint, bare metal, or rust around bolt heads. If you find a bolt, nut, or screw you think is loose, tighten it or report it to your supervisor.
- (4) **Welds.** Look for loose or chipped paint, rust, or gaps where parts are welded together. If you find a bad weld, report it to your supervisor.
- (5) **Electric Wires and Connectors.** Look for cracked, frayed, or broken insulation, bare wires, and loose or broken connectors. Tighten loose connectors. Report any damaged wires to your supervisor.
- (6) **Hoses and Fluid Lines.** Look for wear, damage, and leaks, and make sure clamps and fittings are tight. Wet spots show leaks, but a stain around a fitting or connector can also mean a leak. If a leak comes from a loose fitting or connector, tighten it. If something is broken or worn out, report it to your supervisor.

h. When you check for "operating condition," you look at the component to see if it's serviceable.

2-4. LEAKAGE DEFINITIONS FOR OPERATOR PMCS

It is necessary for you to know how fluid leakage affects the status of the water chiller. Following are types/classes of leakage an operator needs to know to be able to determine the status of the water chiller. Learn these leakage definitions and remember – when in doubt, notify your supervisor.

CAUTION

- **Equipment operation is allowable with minor leakages (Class I or II). Of course, consideration must be given to fluid capacity in the item/system being checked/inspected. When in doubt, notify your supervisor.**
- **When operating with Class I or II leaks, continue to check fluid levels as required in your PMCS.**
- **Class III leaks should be reported immediately to your supervisor.**

- a. CLASS I - Seepage of fluid (as indicated by wetness or discoloration) not great enough to form drops.
- b. CLASS II- Leakage of fluid great enough to form drops but not enough to cause drops to drip from item being checked/inspected.
- c. CLASS III- Leakage of fluid great enough to form drops that fall from item being checked/inspected.

Table 2-1 Operator Preventive Maintenance Checks and Services (PMCS)

Note: If the Water Chiller must be kept in continuous operation, check and service only those items that can be checked and serviced without disturbing operation. Make the complete checks and services when the equipment can be shut down.

ITEM NO.	INTERVAL	ITEM TO CHECK/SERVICE	CREWMEMBER/PROCEDURE	NOT FULLY MISSION CAPABLE IF:
				
1.	Before	Housing	a. Check for cracks, breaks, and proper fastening. b. Check grills for dirt and debris. Clean as necessary.	Housing or doors missing missing.
2.	Before	Choke	Check for proper movement.	Choke not working properly.

Table 2-1 Operator Preventive Maintenance Checks and Services (PMCS) (Continued)

ITEM NO.	INTERVAL	ITEM TO CHECK/SERVICE	CREWMEMBER/PROCEDURE	NOT FULLY MISSION CAPABLE IF:
3.	Before	Exhaust System	a. Check muffler for tightness against locknuts. If needed hand tighten. b. Check muffler and manifold for cracks or leaks.	Muffler missing Muffler or manifold cracked or leaking.
			Check for tightness, cracks and bends.	Fan loose, cracked or bent.

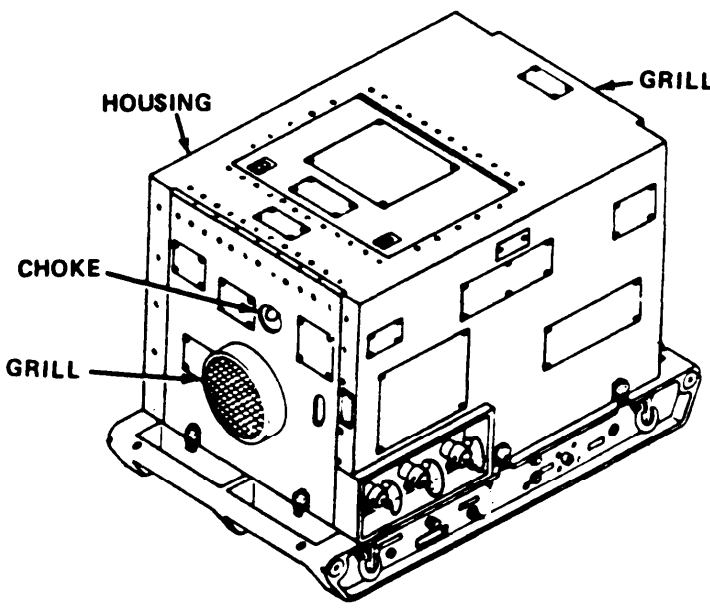
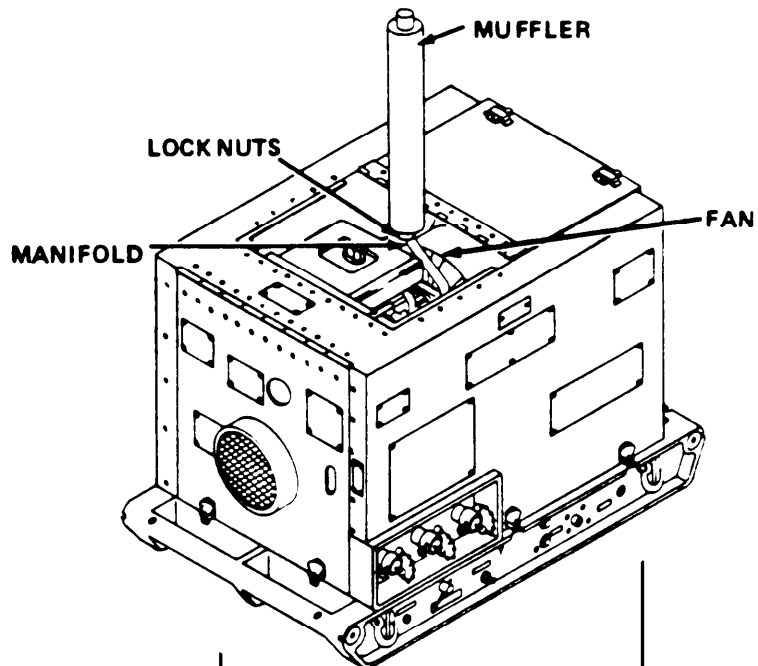

Table 2-1 Operator Preventive Maintenance Checks and Services (PMCS) (Continued)

ITEM NO.	INTERVAL	ITEM TO CHECK/ SERVICE	CREWMEMBER/ PROCEDURE	NOT FULLY MISSION CAPABLE IF:
5.	Before	Belts	Check for wear, cracks, missing teeth, and tightness.	Belt worn, cracked, missing teeth or loose.

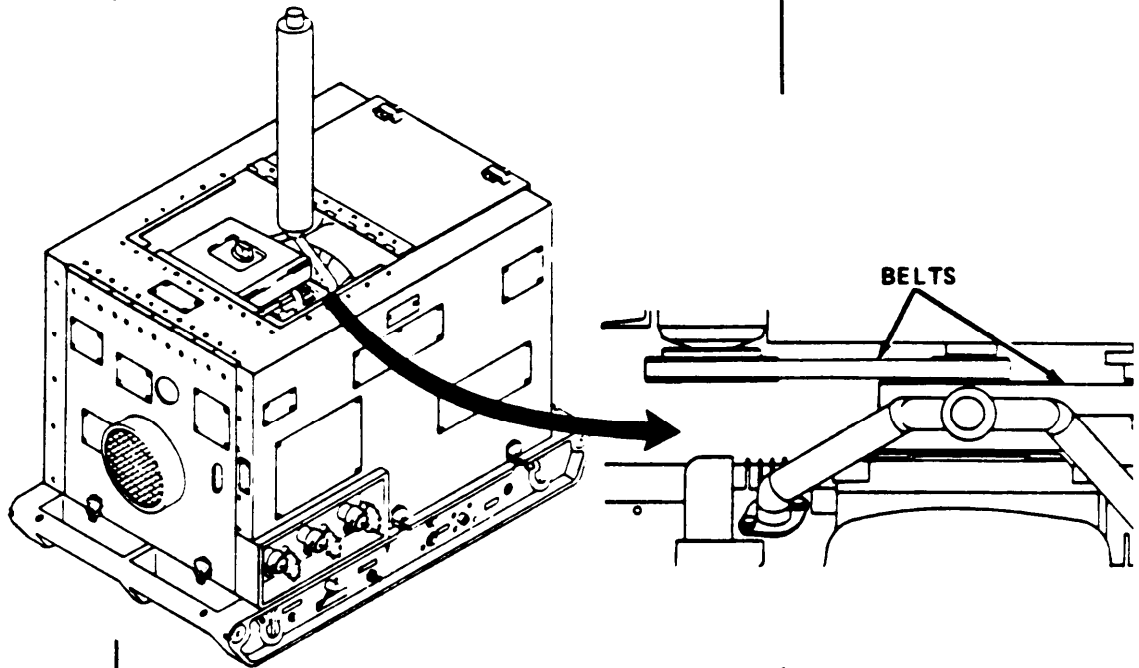

Table 2-1 Operator Preventive Maintenance Checks and Services (PMCS) (Continued)

ITEM NO.	INTERVAL	ITEM TO CHECK/SERVICE	CREWMEMBER/PROCEDURE	NOT FULLY MISSION CAPABLE IF:
6.	Before	Wiring Harness/ pressure switch assemblies	Inspect for loose connections, bare wires, and corrosion.	Connections are loose, or wires are bare or corroded.

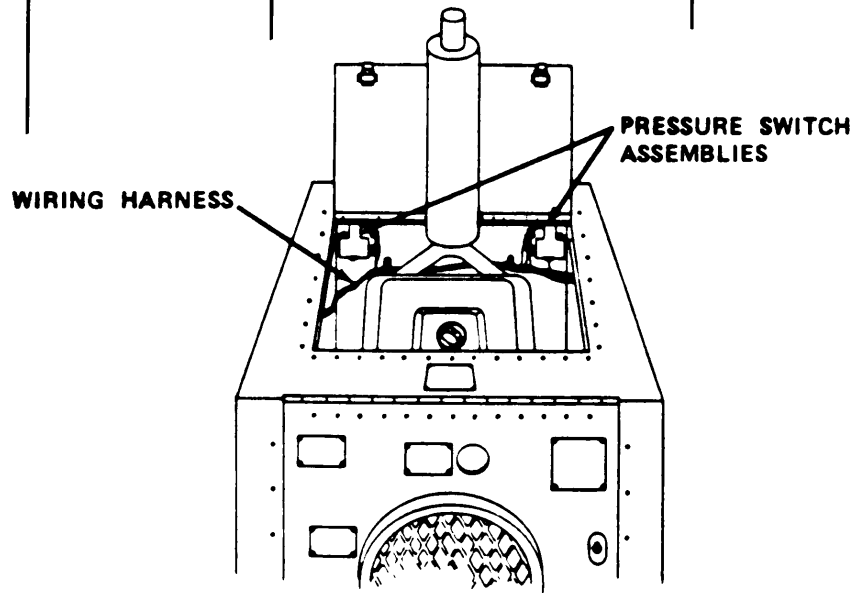

Table 2-1 Operator Preventive Maintenance Checks and Services (PMCS) (Continued)

ITEM NO.	INTERVAL	ITEM TO CHECK/SERVICE	CREWMEMBER/PROCEDURE	NOT FULLY MISSION CAPABLE IF:
7.	Before	Hoses	 <p data-bbox="738 1297 1089 1392">Inspect all hoses for leakage, kinks, crimps, chafing and loose fittings.</p>	Hose leaks or is kinked or crimped.

Table 2-1 Operator Preventive Maintenance Checks and Services (PMCS) (Continued)

ITEM NO.	INTERVAL	ITEM TO CHECK/ SERVICE	CREWMEMBER/ PROCEDURE	NOT FULLY MISSION CAPABLE IF:
8.	Before	Crankcase Oil	 <p data-bbox="678 1272 1029 1373">Check level. Add oil (item 10 appendix E) as necessary to <u>Full</u> mark on dipstick.</p>	<p data-bbox="1084 1272 1360 1339">Oil level below <u>Add</u> mark on dipstick.</p>

Table 2-1 Operator Preventive Maintenance Checks and Services (PMCS) (Continued)

ITEM NO.	INTERVAL	ITEM TO CHECK/SERVICE	CREWMEMBER/PROCEDURE	NOT FULLY MISSION CAPABLE IF:
				
9.	Before	Start/Run Water Control	Turn control back and forth to check operation.	Control will not move.
10.	Before	12/24 Volt Input For Starting Connection.	Check for damage.	Connector damaged.

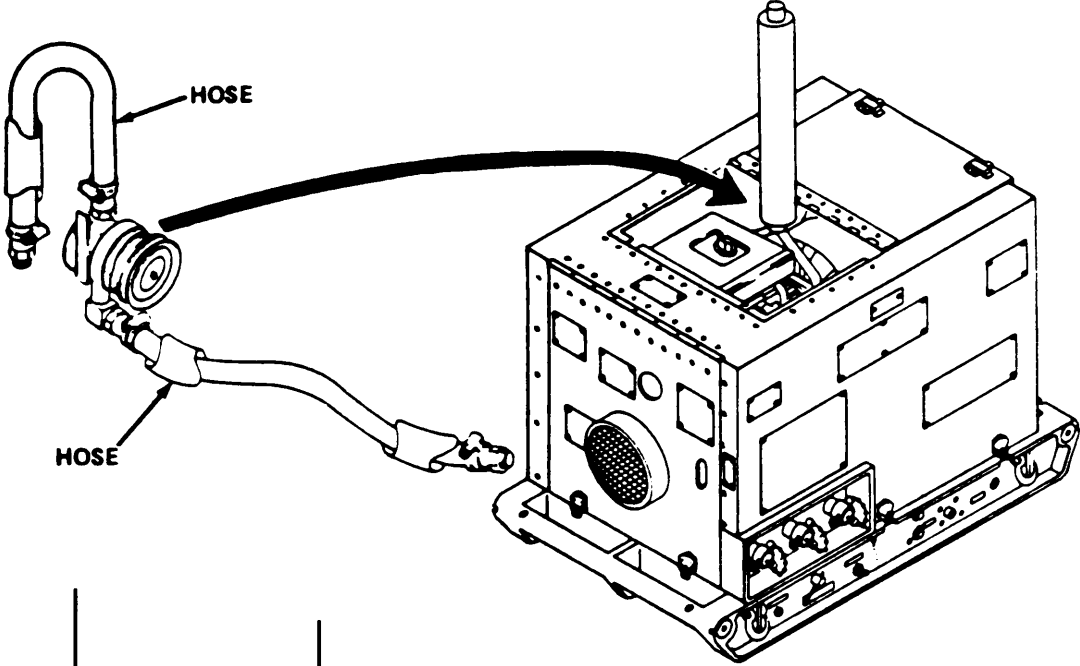
Table 2-1 Operator Preventive Maintenance Checks and Services (PMCS) (Continued)

ITEM NO.	INTERVAL	ITEM TO CHECK/ SERVICE	CREWMEMBER/ PROCEDURE	NOT FULLY MISSION CAPABLE IF:
11.	Before	Skid	Check for cracks and broken welds.	Skid cracked or broken.
				
12.	Before	Trailer Mounting Kit.	Check that load binders or grab hooks are fastened. Fasten as needed.	Load binders or grab hooks are loose or broken.
				

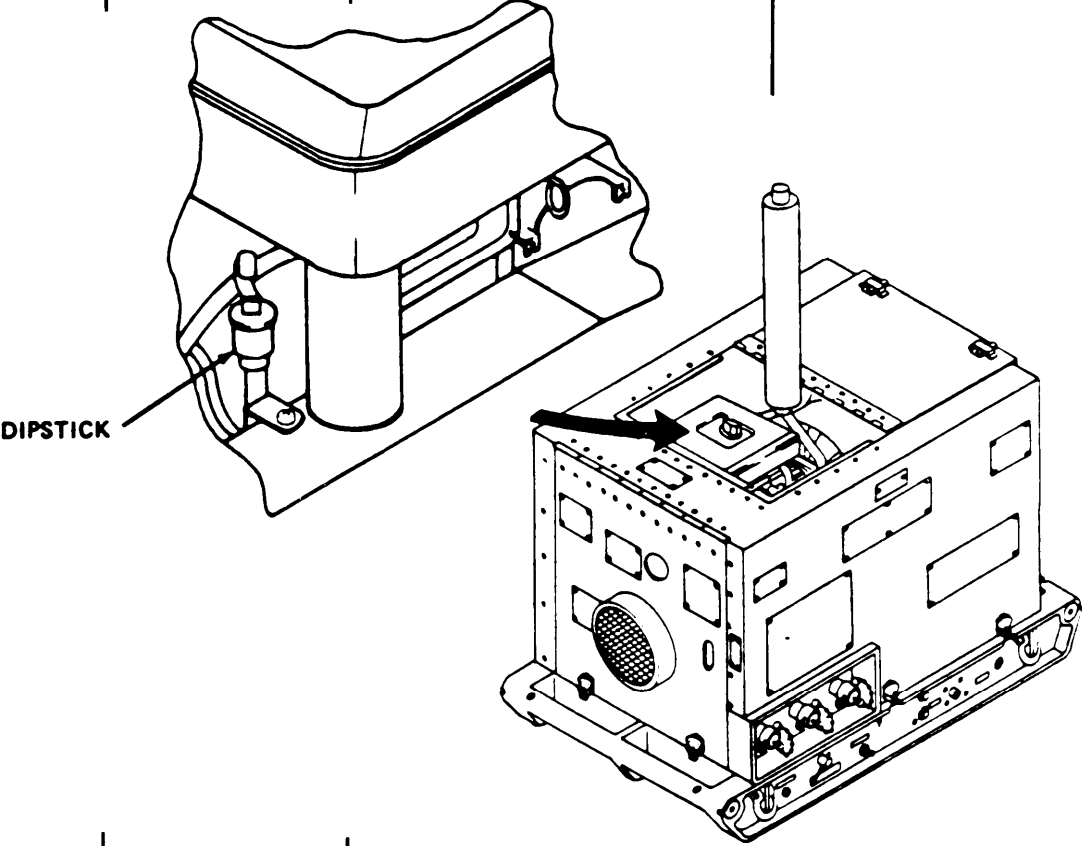
Table 2-1 Operator Preventive Maintenance Checks and Services (PMCS) (Continued)

ITEM NO.	INTERVAL	ITEM TO CHECK/SERVICE	CREWMEMBER/PROCEDURE	NOT FULLY MISSION CAPABLE IF:
13.	Before	Fuel Line	Check for damage or leaks.	Fuel line damaged or is leaking.
14.	Before	Water Hoses	Check all water hoses for leaks or cracks.	Hoses are leaking or cracked.
15.	Before	Fuel	Check level of fuel; fill as required.	
16.	Daily	Refrigerant	Look through refrigerant sight glass after 15 to 20 minutes of operation.	Refrigerant sight glass not showing clear, bubble-free refrigerant with green center.
17.	Daily	Water Storage	Check supply. Refill with potable water as necessary.	Water supply low.

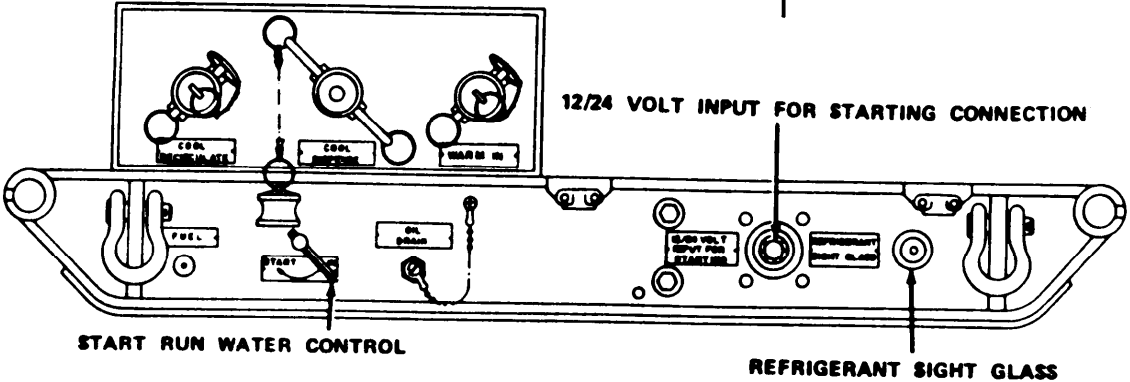
Table 2-1 Operator Preventive Maintenance Checks and Services (PMCS) (Continued)

ITEM NO.	INTERVAL	ITEM TO CHECK/ SERVICE	CREWMEMBER/ PROCEDURE	NOT FULLY MISSION CAPABLE IF:
18.	Weekly	Air Cleaner Foam Precleaner	After 25 hours of engine operation or weekly, which ever comes first. Remove and service. (See para 3-5).	Foam precleaner dirty.
19.	Weekly	Condenser	Check for dirt and debris.	Condenser full of dirt or debris.
20.	Monthly	Air Cleaner Paper Cartridge.	After 100 hours of engine operation or monthly, which ever comes first. Remove and clean (See para 3-5).	Cartridge dirty.

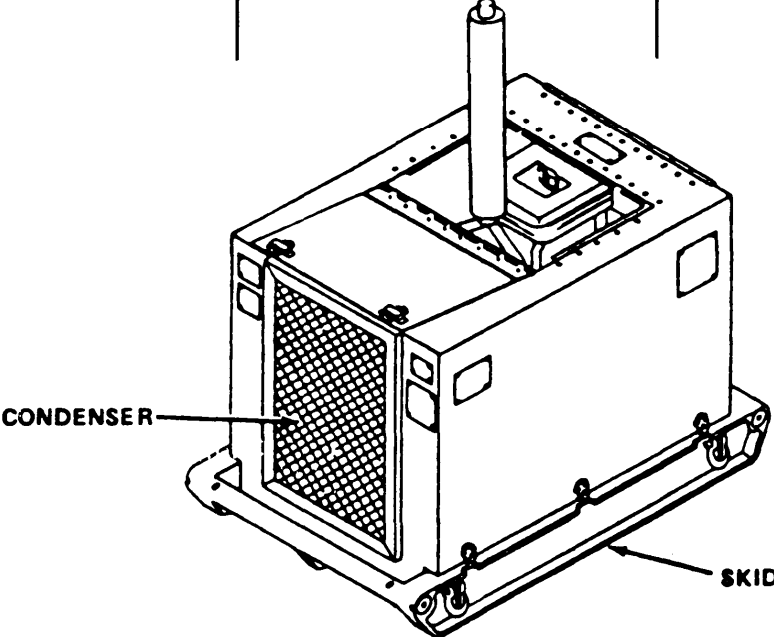
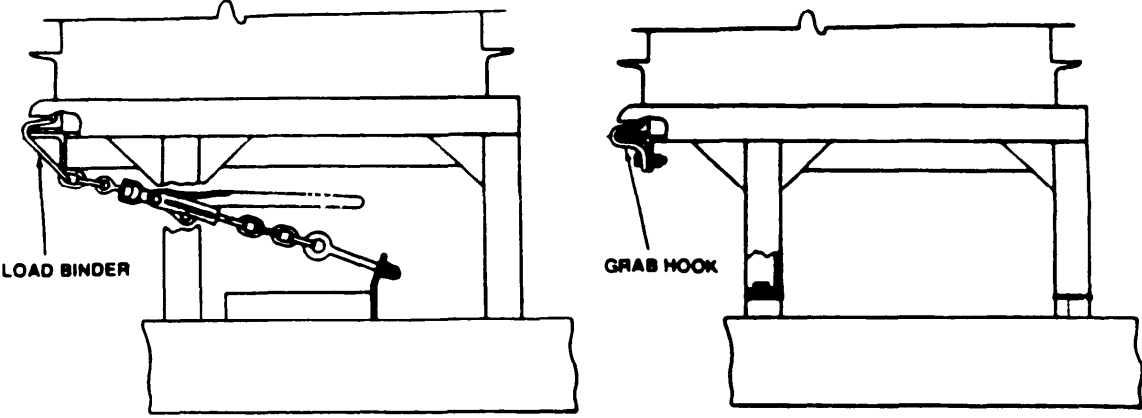
Section III. OPERATION UNDER USUAL CONDITIONS

2-5. ASSEMBLY AND PREPARATION FOR USE

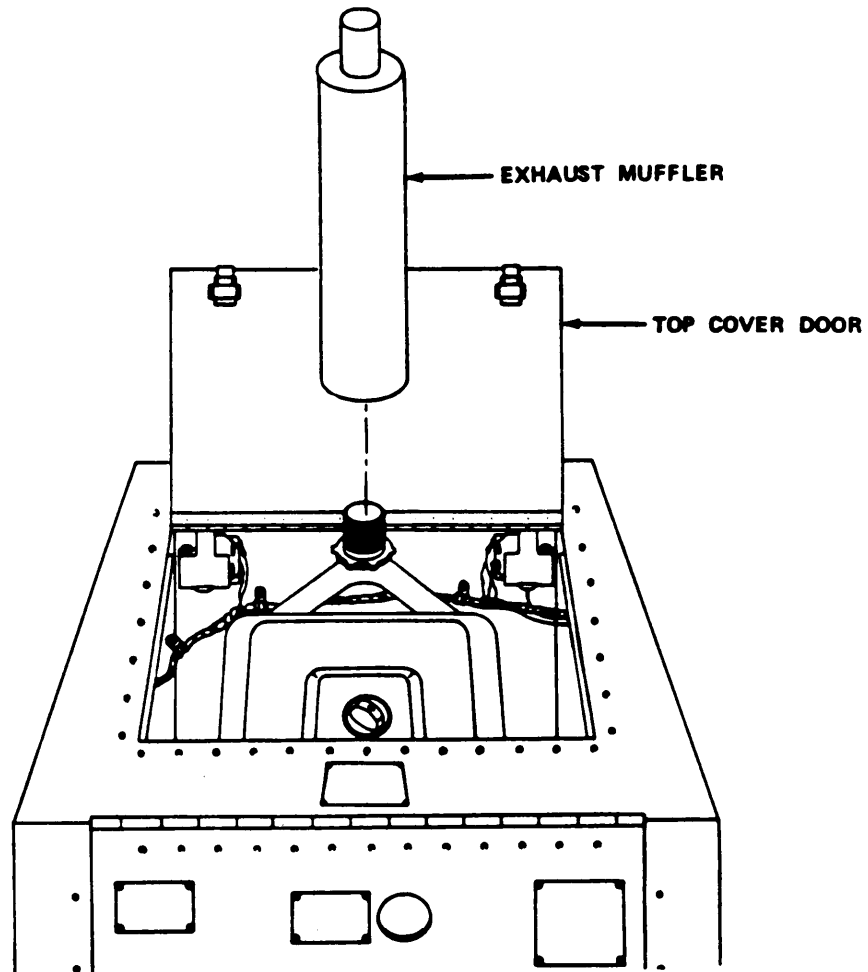

- 1 Unlatch and open top cover door of water chiller.
- 2 Remove muffler from duffle bag. Install exhaust muffler on engine exhaust port. Hand-tighten on existing locknuts.

2-5. ASSEMBLY AND PREPARATION FOR USE (CONT)

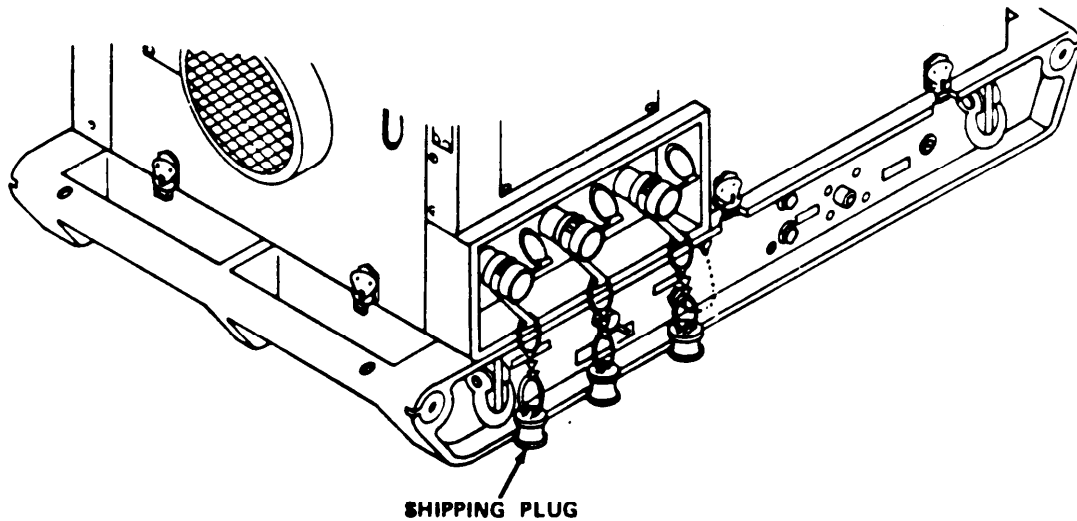

- 3 Remove shipping plugs from COOL RECIRCULATE, COOL DISPENSE, and WARM IN connections. Make sure no foreign matter is in openings.
- 4 Remove fuel line and four water hoses from support kit duffle bag.

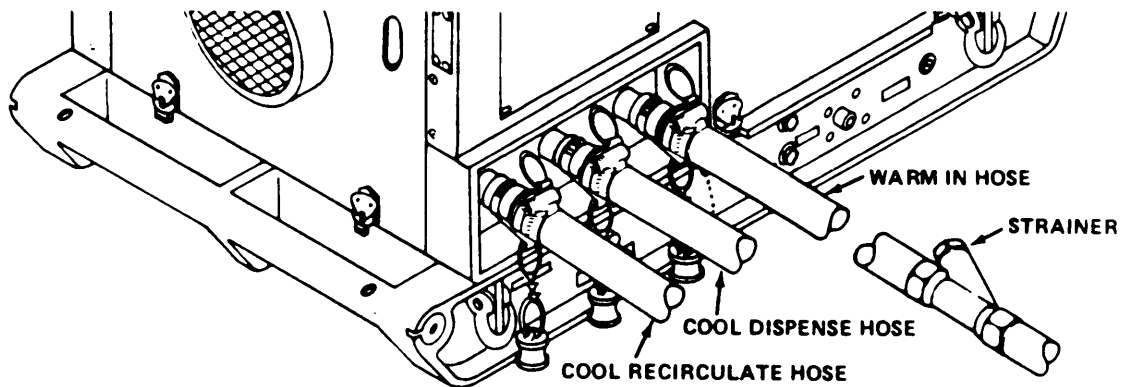

- 5 Install three hoses in connections on water chiller. Connect free end of hose attached to WARM IN connection to strainer kit. Connect fourth hose from water supply to other end of strainer kit. Turn strainer so that arrow on side agrees with flow direction.

2-5. ASSEMBLY AND PREPARATION FOR USE (CONT')

6 Route hose from COOL RECIRCULATE connection to return cool water to water supply.

7 Attach dispense nozzle to hose connected to COOL DISPENSE connection.

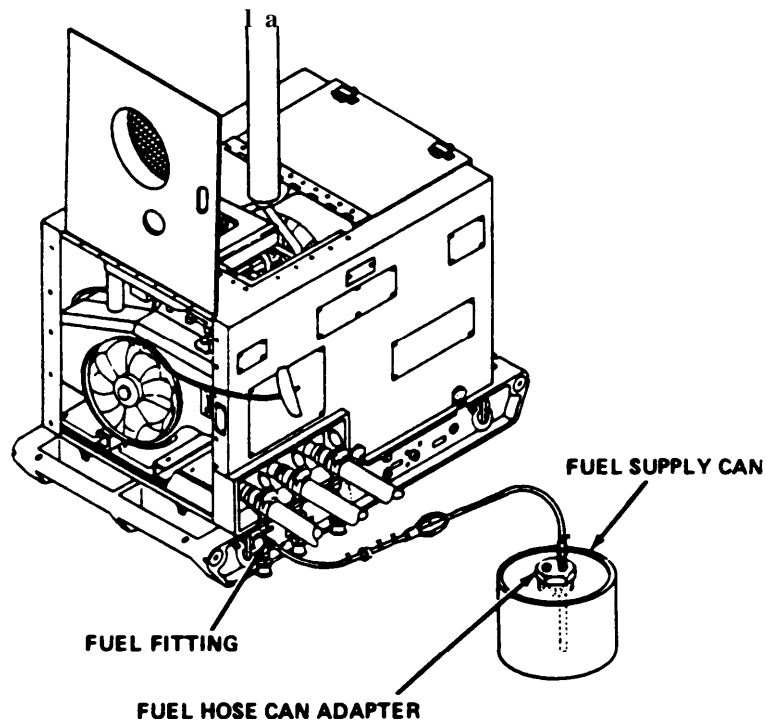

WARNING

Fuel is flammable. To prevent possible fire or explosion, DO NOT bring sparks or open flame near fuel.

8 Screw can adapter and fuel hose into fuel supply can. Connect other end of fuel hose to quick-disconnect FUEL fitting on front of water chiller.

2-6. OPERATING PROCEDURE

WARNING

- To prevent damage to hearing, wear hearing protection at all times within 4 feet (1.2 meters) of water chiller.
- Do not operate water chiller after shipment or repairs until system has been purged with disinfectant to prevent water contamination. (See paragraph 2-6b.)

CAUTION

- To prevent clogging, DO NOT operate water chiller without strainer. (See para 2-5, step 5.)
- Failure to connect all water hoses may cause damage to equipment. DO NOT operate water chiller without adequate water supply.

NOTE

- Install exhaust muffler and connect water hoses before starting engine. (See paragraph 2-5.)
- Perform before (B) PMCS.

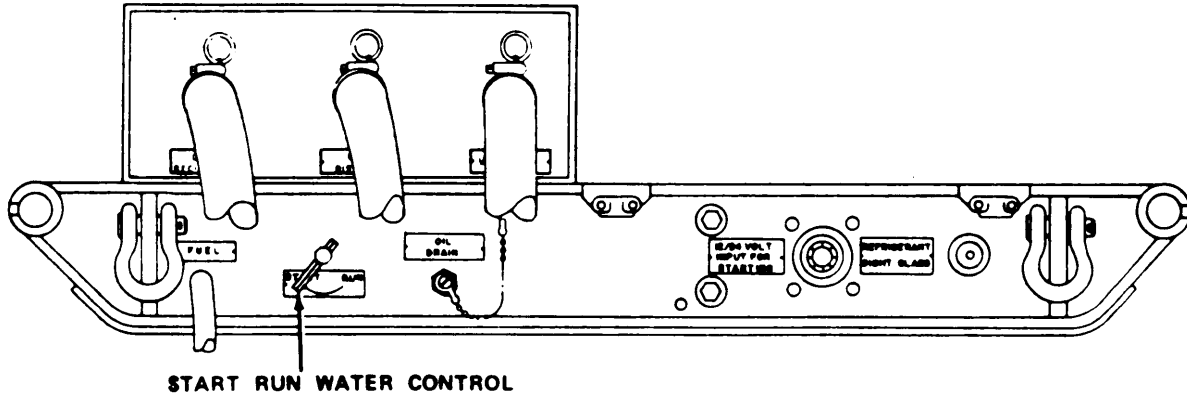

a. Startup

- 1 Place START RUN water control in START position.

2-6. OPERATING PROCEDURE (CONT)

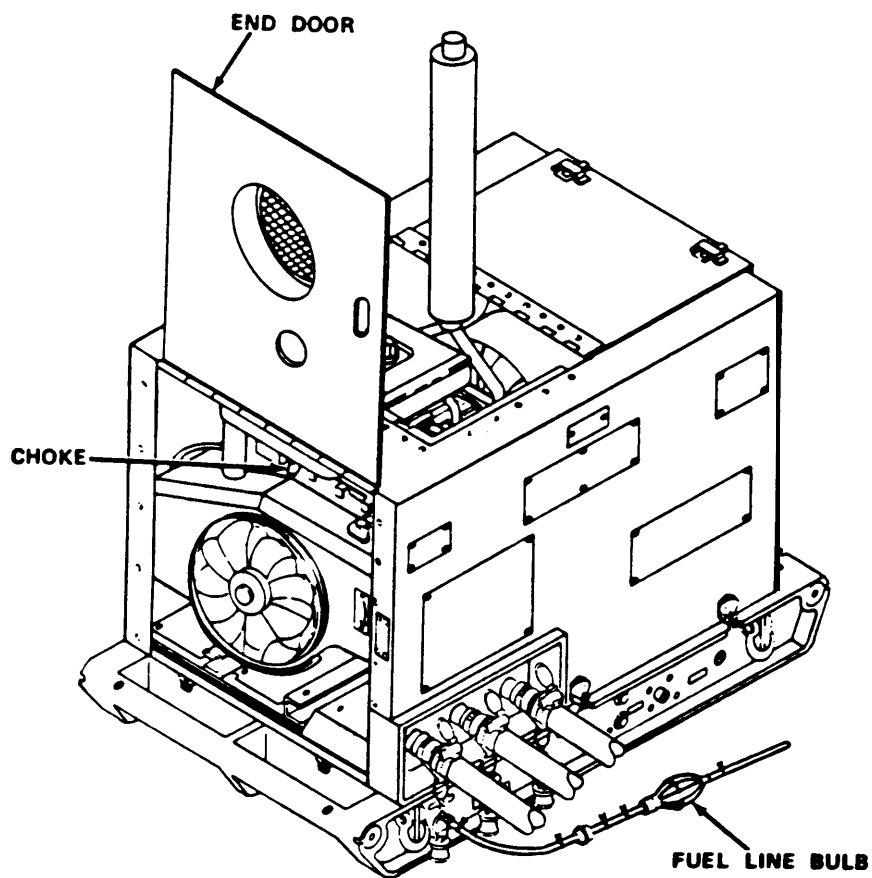

2 Open end door.

NOTE

Choking is usually not required for restarting within 30 minutes after engine temperature reaches 90°F (32°C).

- 3 If needed, pull out choke to engage.
- 4 Squeeze and release bulb in fuel line until pressure is felt.

2-6. OPERATING PROCEDURE (CONT)

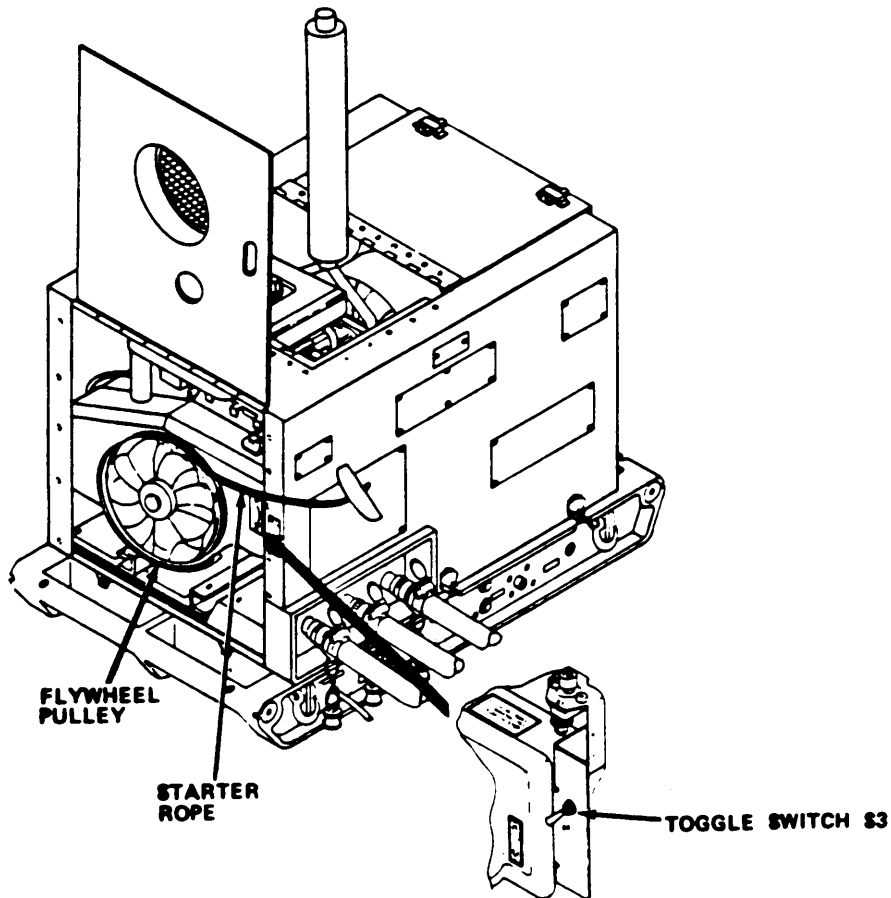

NOTE

Step 5 is for starting when 12-volt power source is not available. Two persons may be required for this step. Step 6 is for starting using 12-volt power source.

- 5 If 12-volt power source unavailable: Wrap starter rope from left to right around flywheel pulley. Hold toggle switch S3 in START position. Pull starter rope.

2-6. OPERATING PROCEDURE (CONT)

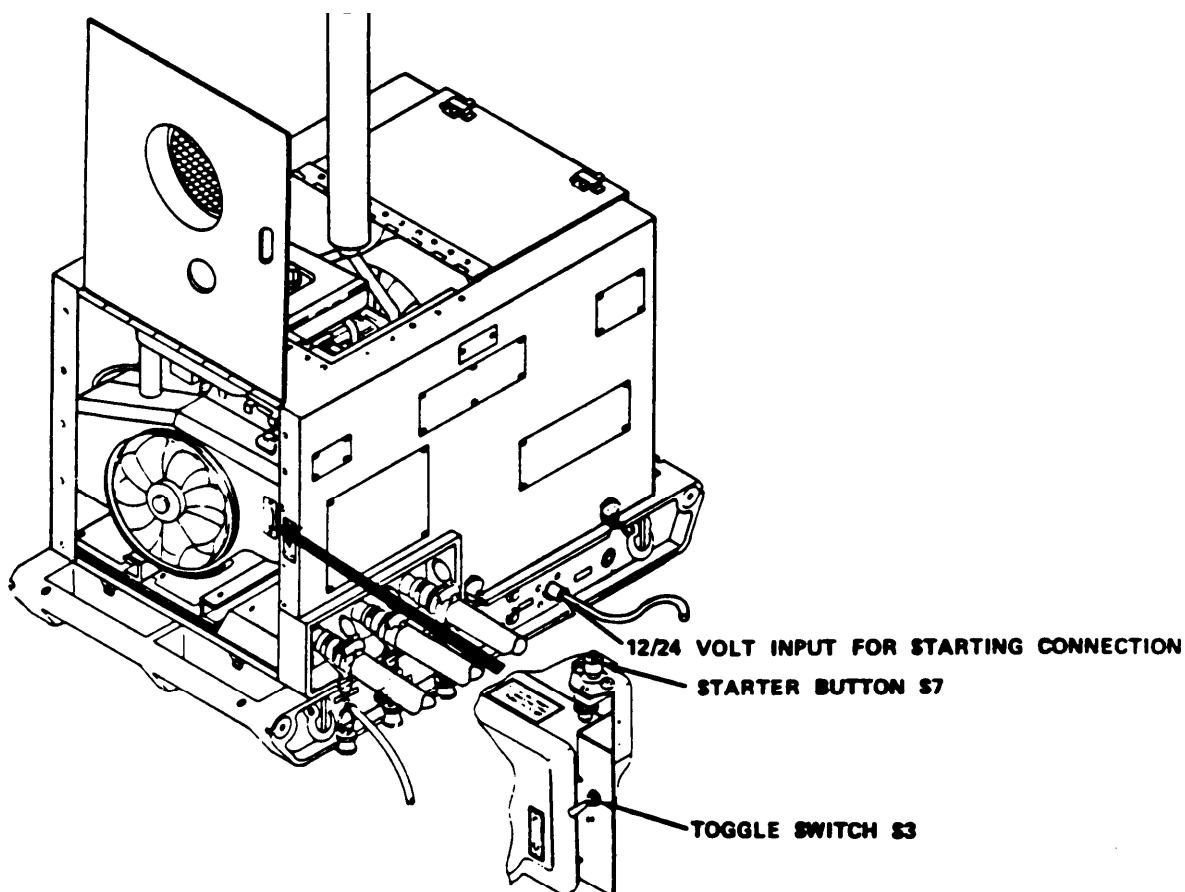
**CAUTION**

To prevent damage to starter

- If engine fails to start within 15 seconds, release starter button,
 - Allow starter to cool at least 10 minutes before trying to restart.
 - If only 24-volt power source available reduce power source to 12 volts.
- 6 If 12-volt power source available: Insert cable from source into 12/24 VOLT INPUT FOR STARTING connection. Hold toggle switch S3 in START position. Push starter button S7. Release starter button S7 when engine starts.

2-6. OPERATING PROCEDURE (CONT)

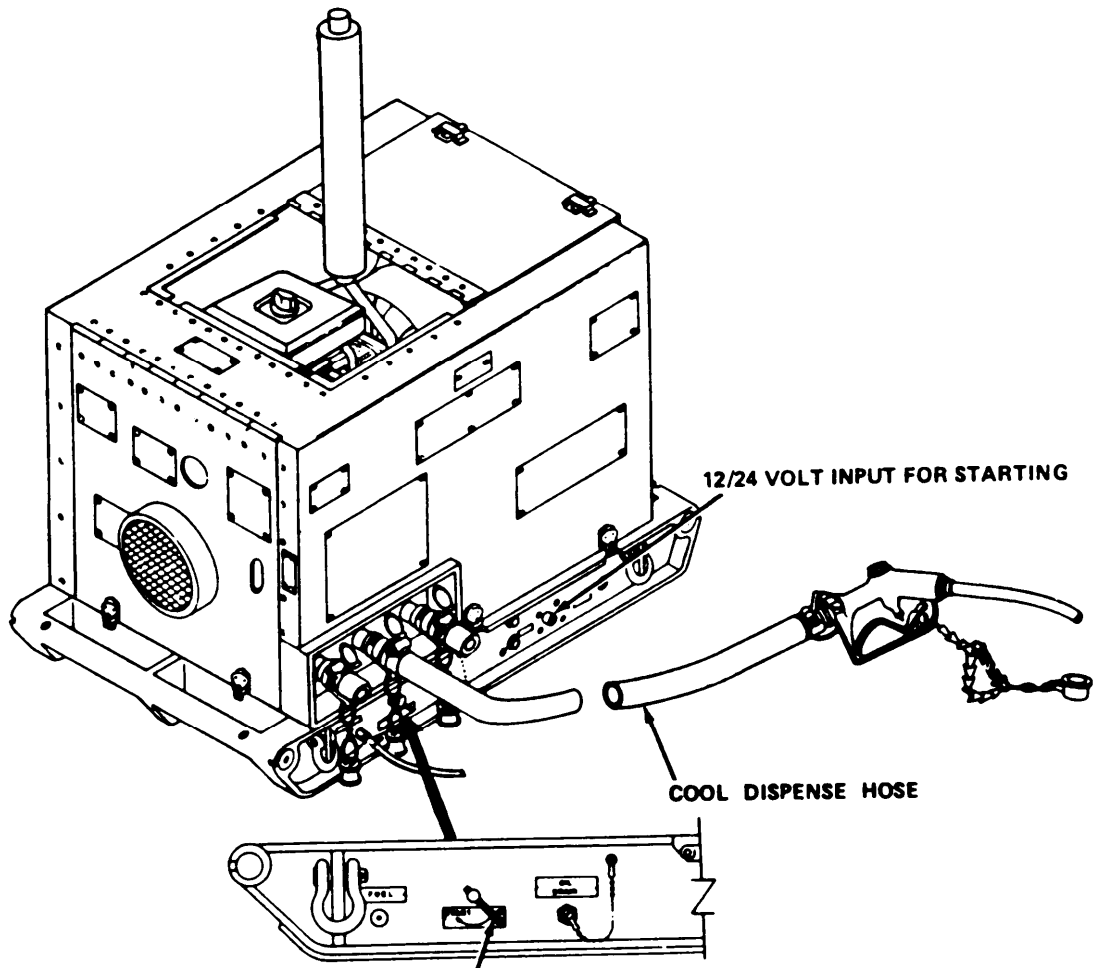

- 7 Open dispense nozzle. When there are few or no air bubbles in water from cool dispense hose, place START RUN control in RUN position.
- 8 If used, disconnect power cable from 12/24 VOLT INPUT FOR STARTING connection.
- 9 After 25 hours of operation, notify organizational maintenance to change oil.

2-4. OPERATING PROCEDURE (CONT)

b . Purging the Water System. tern. Before using the water chiller after shipment or repairs, the system must be purged with disinfectant.

WARNING

- Calcium hypochlorite can cause serious injury if not handled properly. Heed all safety measures below.
- If calcium hypochlorite comes into contact with skin or eyes, flush right away with water. Get medical help.
- Store calcium hypochlorite in cool, dry place. Keep container closed.
- Mix only in accordance with directions for use.
- DO NOT allow calcium hypochlorite to mix with any other materials, such as fuels, oils, paint products, or ammonia. This may cause fire or hazardous gases.

1 Fill two 5-gallon (19-liter) pails with water. Add 0.1 ounce (2.8 grams) of calcium hypochlorite powder (item 4, appendix E) to each. Stir each pail with a wooden paddle until powder is dissolved.

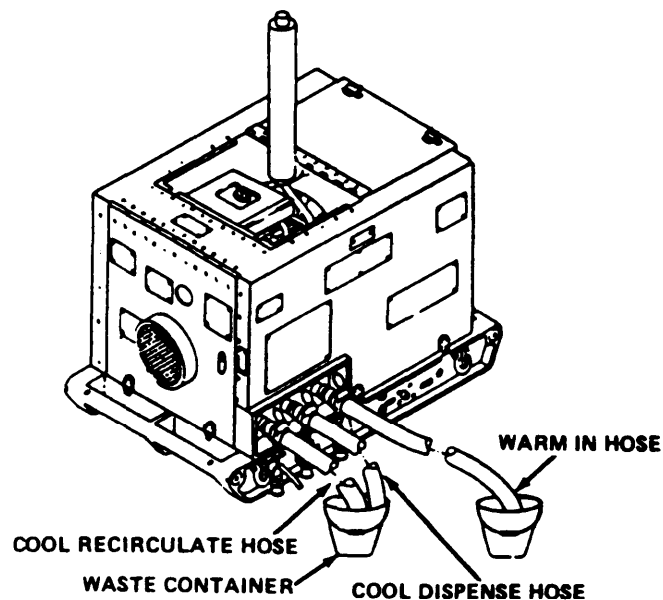

2-6. OPERATING PROCEDURE (CONT)

CAUTION

To prevent clogging, do not operate chiller without strainer in WARM IN hose.

- 2 Connect three water hoses to water chiller. Place other end of warm in hose in pail of solution. Water will be discharged from cool recirculate and cool dispense hoses into waste container.
- 3 Start water chiller. (See paragraph 2-6a.)

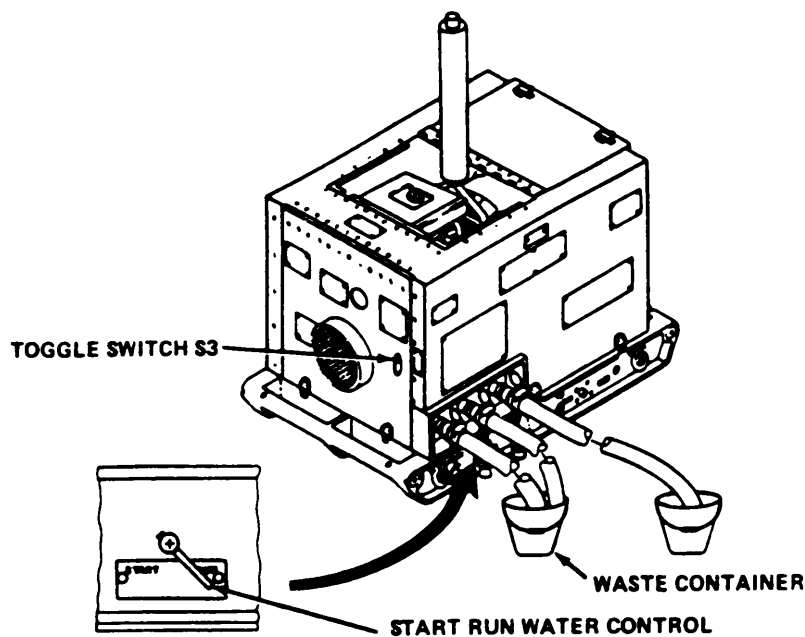

CAUTION

To prevent undissolved hypochlorite crystals from entering system, do not use water from bottom of pail. Leave about 1/2 gallon (2 liters) of solution in each pail.

- 4 With engine running, place START RUN water control in RUN position and circulate both pails of chlorine solution through water system.

2-6. OPERATING PROCEDURE (CONT)

5 Allow chlorine solution to circulate through water system until depleted. Open nozzle on dispensing hose periodically during the cycle and dispense chlorine solution until both pails are empty. Place toggle switch S3 in STOP position. Remove warm in hose from pail.

6 Connect warm in hose to potable water supply.

7 Start engine. (See paragraph 2-6a.) Flush water system thoroughly, discharging water from cool dispense hose to waste container. Connect cool recirculate hose to potable water supply. Water chiller is now ready for operation.

c. Automatic Shutdown. The water chiller will be automatically shut down by safety switches under the following conditions:

- Refrigerant pressure too high.
- Refrigerant pressure too low.
- Water temperature too high.
- Water temperature too low.

If engine stops suddenly, notify unit maintenance.

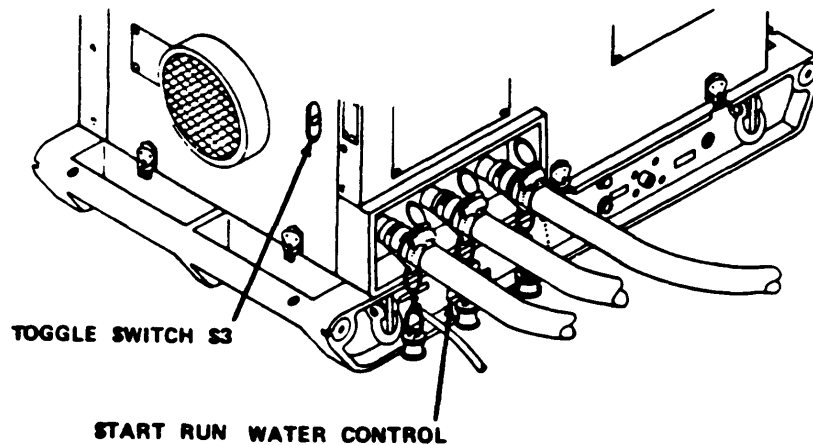

d. Shutdown

1 Hold toggle switch S3 in STOP position until engine stops, then release. Place START RUN water control lever in START position. (Equipment is now in standby condition.)

2-6. OPERATING PROCEDURE (CONT)

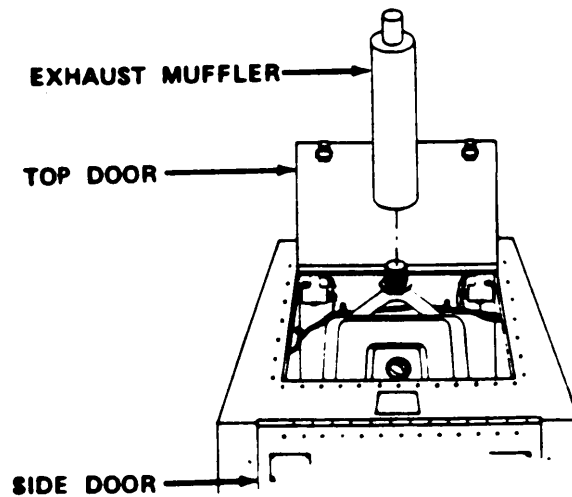

WARNING

To prevent burns, wait until exhaust muffler cools before trying to remove it.

2 Remove exhaust muffler. Place in duffle bag.

3 Close and latch top and side doors.

2-7. PREPARATION FOR MOVEMENT

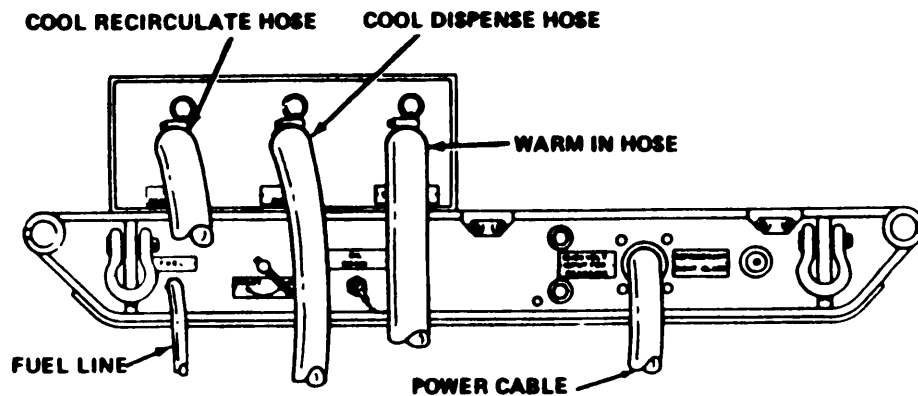

1 Shut down water chiller. (See paragraph 2-6d.)

2-7. PREPARATION FOR MOVEMENT (CONT)

WARNING

Fuel is flammable. To prevent possible fire or explosion, DO NOT bring sparks or open flame near fuel.

- 2 Disconnect fuel hose from water chiller and from fuel supply. Drain and place in duffel bag.
- 3 Disconnect three water hoses from water chiller connections. Install shipping plugs. Disconnect hoses from water storage tank. Drain hoses and place in duffel bag.

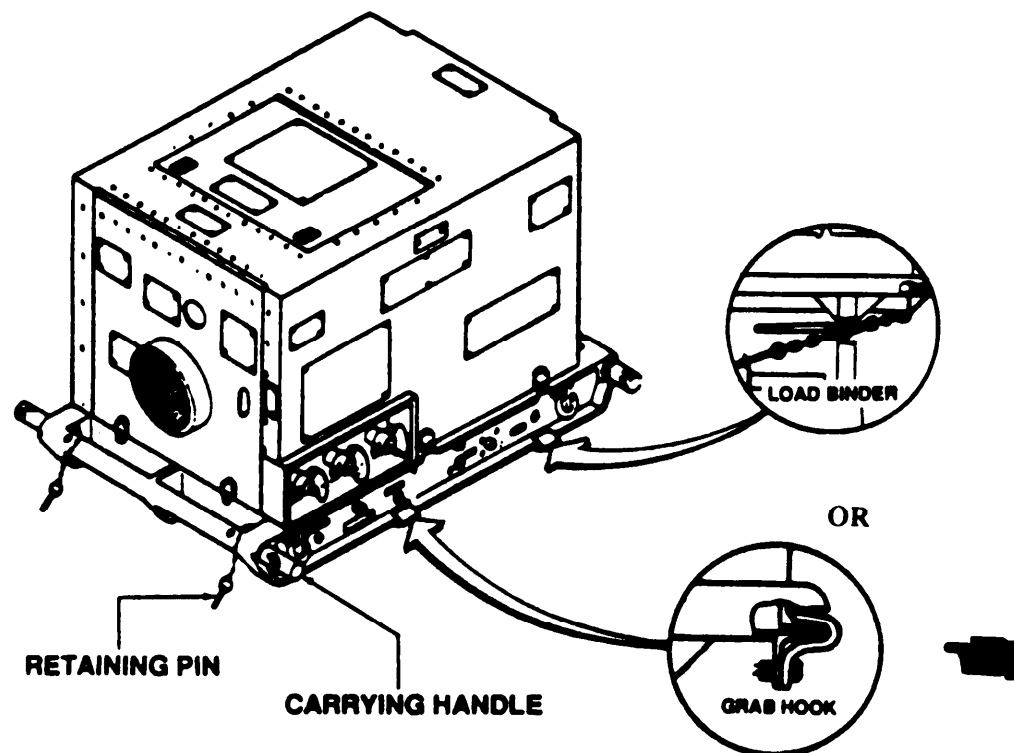

4 To disconnect water chiller from M149 trailer:

- (a) Disconnect two load binders or grab hooks.
- (b) Pull out four retaining pins. Pull out four carrying handles.

WARNING

To prevent personal injury, four persons are required to lift water chiller.

- (c) Slide water chiller out of mounting kit.

2-8. OPERATING INSTRUCTIONS ON DECALS AND INSTRUCTION PLATES

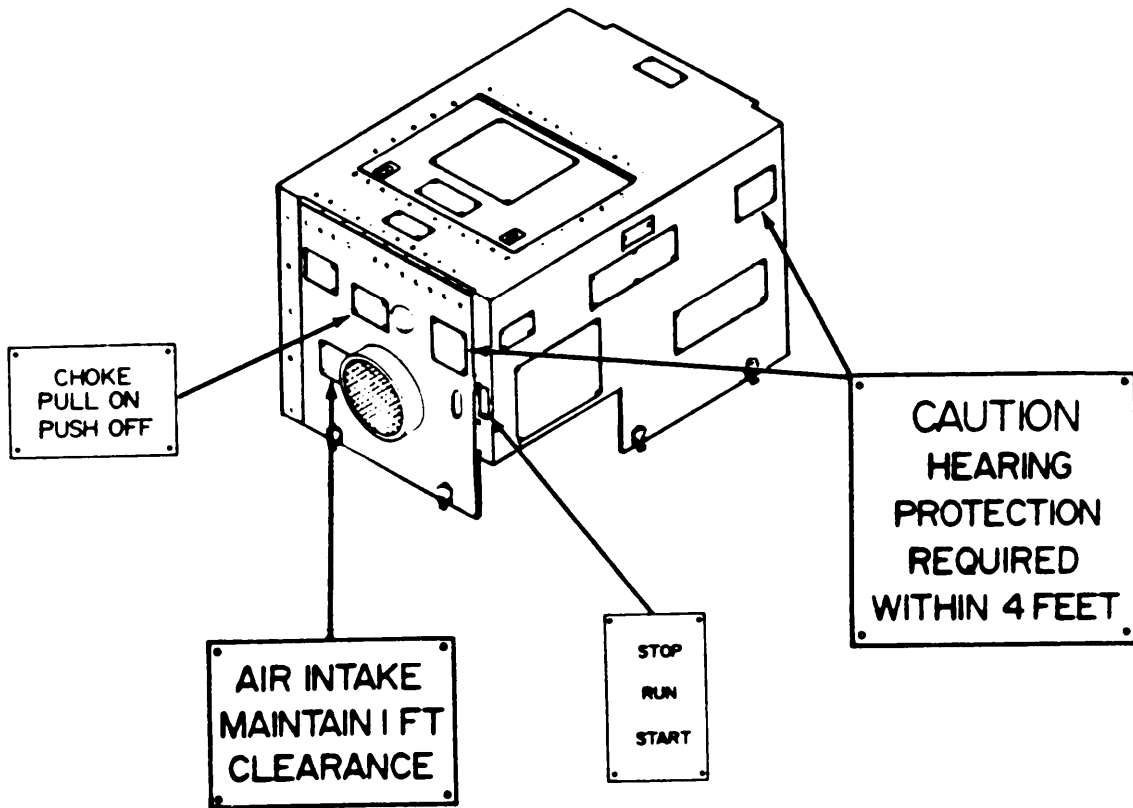

2-8. OPERATING INSTRUCTIONS ON DECALS AND INSTRUCTION PLATES (CONT)

SMWC

OPERATING PROCEDURE: Refer to O & M Manual regarding sanitizing and maintenance.

START-UP PREPARATION.

- Remove auxiliary equipment from duffle bag
- Route water hose from supply source and connect to strainer kit assembly
- Turn strainer so that arrow on side agrees with flow direction
- Connect a second hose between strainer and WARM IN fitting on SMWC

CAUTION: DO NOT OPERATE WITHOUT STRAINER

- Route a third water hose to return cooled water to supply source
- Connect to COOL RECIRCULATE fitting on SMWC
- Connect nozzle hose to COOL DISPENSE fitting on SMWC
- Open hinged lid of SMWC Leave open while operating
- Check engine oil level, add oil if required, NSN 9150-00-166-6705 (15W-40)
- Attach fuel hose to FUEL fitting on SMWC and other end to fuel source, NSN 9130-00-160-1817 (Combat Automotive Type I)
- Install muffler on exhaust manifold
- Be sure water valves at tanks, if provided, are open
- Hold engine switch in START position
- Turn START RUN handle of SMWC to START position
- Pull CHOKE for cold start

CAUTION: DO NOT RUN ENGINE UNLESS WATER HOSES ARE CONNECTED

Start engine with pull cord or with 12 volt DC power source to SLAVE RECEPTACLE. After approximately 10 seconds of operation, turn START RUN handle to RUN position. Release engine switch to return to RUN.

Water will automatically recirculate to supply source when COOL DISPENSE nozzle is not in use.

CAUTION
LID MUST BE OPEN
WHEN RUNNING

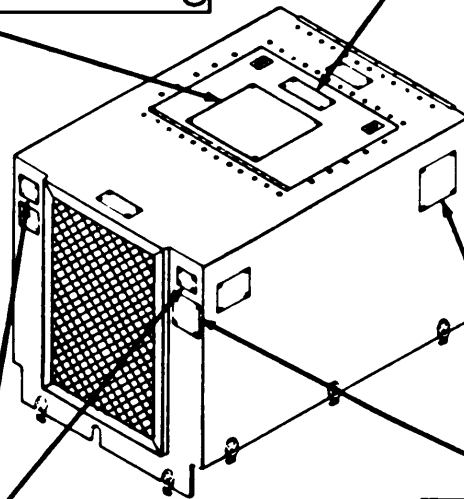

AIR INTAKE
MAINTAIN 1 FT
CLEARANCE

CAUTION
HEARING
PROTECTION
REQUIRED
WITHIN 4 FEET.

Section IV. OPERATION UNDER UNUSUAL CONDITIONS

2-9. OPERATION IN UNUSUAL WEATHER

- a. Sandy or Dusty Conditions. Check air filter elements and condenser daily. See table 2-1, item nos. 18, 19, and 20.
- b. Saltwater or Humid Conditions. Check for corrosion of wiring harness and pressure switch assemblies. See table 2-1, item no. 6.
- c. Extreme Heat Conditions. Check housing grills and crankcase oil daily. See table 2-1, item nos. 1 and 8.

CHAPTER 3
OPERATOR MAINTENANCE

Section I. LUBRICATION INSTRUCTIONS

3-1. CRANKCASE OIL. The only necessary lubrication for the water chiller is oil for the crankcase. See table 2-1 for adding oil. Oil should be changed after 25 hours of operation. Change oil as follows:

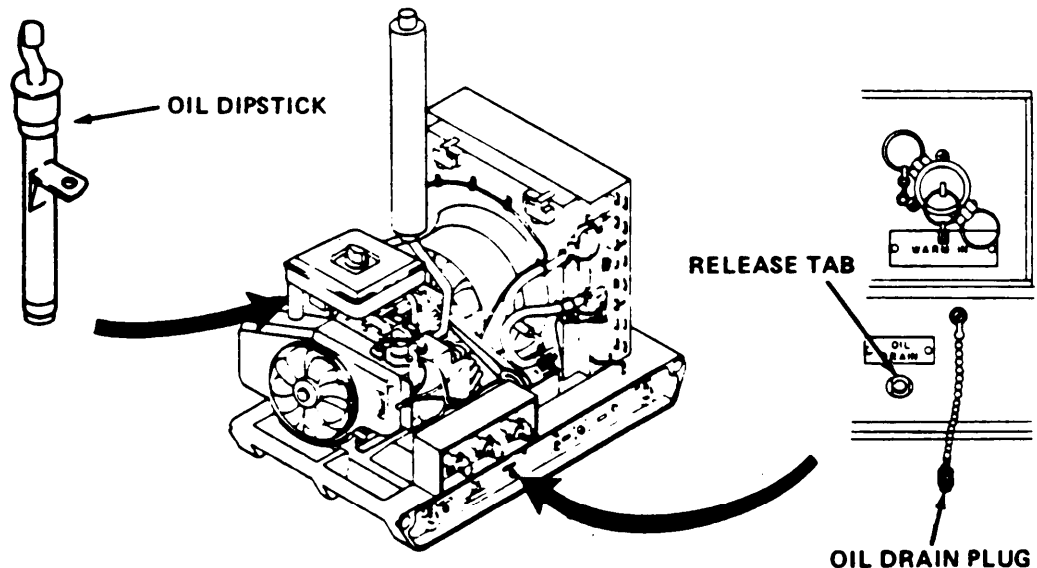

- 1 Place oil drain pan (appendix D) under OIL DRAIN.
- 2 Press release tab, pull oil drain plug, and let oil drain. Install plug. Discard waste oil.
- 3 Pull out dipstick. Fill engine with 3.5 pints (1.65 liters) of oil (MIL-L46152) through oil filler tube. Top up to FULL mark on dipstick. Install dipstick.

Section II. TROUBLESHOOTING PROCEDURES

3-2. OPERATOR TROUBLESHOOTING. Operator troubleshooting consists of performing the preventive maintenance checks and services (PMCS), table 2-1. If water chiller fails to start or does not operate properly, perform your PMCS. If the problem is not corrected, notify unit maintenance.

Section III. OPERATOR MAINTENANCE PROCEDURES

3-3. GENERAL. This section contains operator/crew maintenance instructions authorized by the Maintenance Allocation Chart (MAC), appendix B, and by the source, maintenance, and recoverability (SMR) coded items to support the water chiller.

3-4. AIR CLEANER FOAM PRECLEANED SERVICE

This task covers:

- a. Removal
- b. Cleaning
- c. Installation

INITIAL SETUP

Materials/Parts

- Engine oil, item 10, appendix E
- Liquid detergent, item 6, appendix E

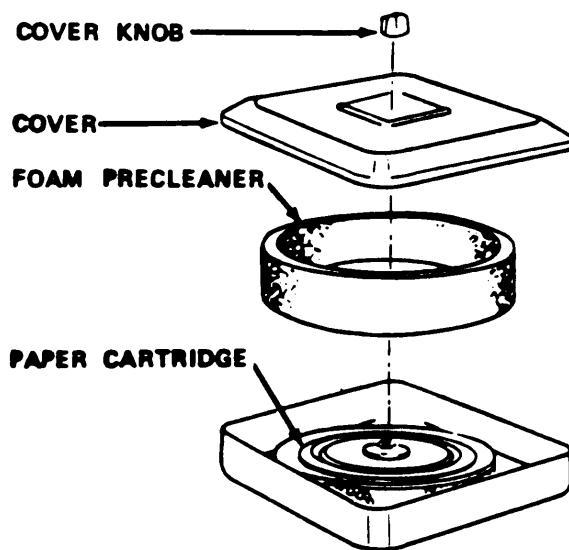

a. Removal

- 1 Remove cover knob. Lift off cover.
- 2 Remove foam precleaned from around paper cartridge.

b. Cleaning

- 1 Wash foam precleaned with liquid detergent and water. Rinse and squeeze dry.
- 2 Oil with 1 oz. (30 cc) of engine oil (MIL-L-46152). Squeeze to spread oil evenly.

3-4. AIR CLEANER FOAM PRECLEANED SERVICE (CONT)

c. Installation

1 Install foam precleaner around paper cartridge.

2 Install cover. Install cover knob.

3-5. AIR CLEANER PAPER CARTRIDGE SERVICE

This task covers:

- a. Removal
- b. Cleaning
- c. Installation

Materials/Parts

Liquid detergent, item 6, appendix E

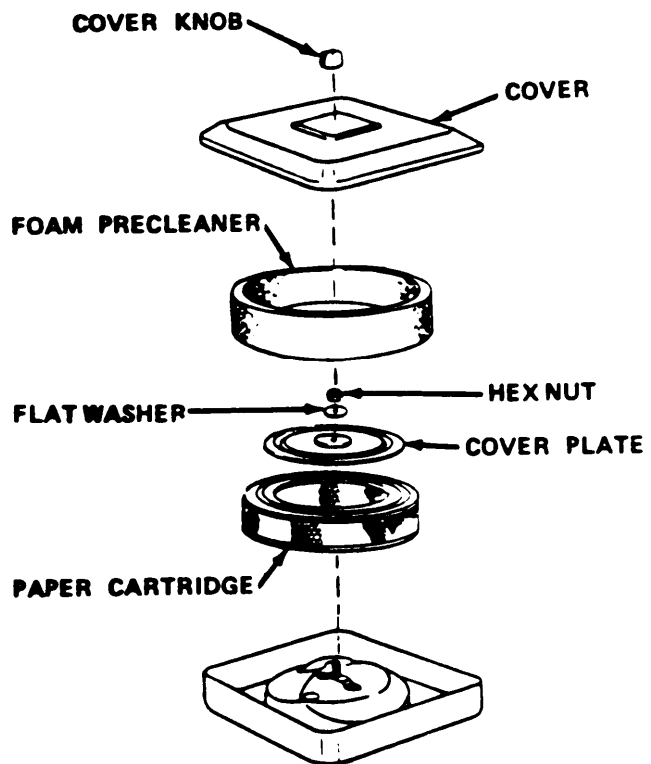

a. Removal

1 Remove cover knob. Lift off cover.

2 Remove foam precleaned from around paper cartridge and clean it (para 3-4).

3 Remove hexnut and flatwasher.

4 Lift off cover plate. Remove paper cartridge.

3-5. AIR CLEANER PAPER CARTRIDGE SERVICE (CONT)

b. Cleaning

- 1 Tap cartridge gently on hard surface or wash in detergent and water.
- 2 After washing, rinse thoroughly in clear water. Dry thoroughly before using.
- 3 Wipe off cover plate with clean cloth.
- 4 Service air cleaner foam precleaned (para 3-4).

c. Installation

- 1 Install paper cartridge and cover plate.
- 2 Install flatwasher and hexnut. Hand-tighten.
- 3 Install foam precleaned around paper cartridge.
- 4 Install cover and cover knob.

**CHAPTER 4
UNIT MAINTENANCE**

**Section I - REPAIR PARTS; SPECIAL TOOLS; TEST, MEASUREMENT, AND
DIAGNOSTIC EQUIPMENT (TMDE); AND SUPPORT EQUIPMENT**

	Para		Para
Common Tools and Equipment	4-1	Repair Parts	4-3
Special Tools, TMDE, and Support Equipment	4-2		

Section II. SERVICE UPON RECEIPT

Unpacking and Inspection	4-4
------------------------------------	-----

**Section III. UNIT PREVENTIVE MAINTENANCE CHECKS
AND SERVICES (PMCS)**

General	4-5	PMCS Procedures	4-6
-------------------	-----	---------------------------	-----

Section IV. UNIT TROUBLESHOOTING

Unit Troubleshooting	4-7
--------------------------------	-----

Section V. UNIT MAINTENANCE PROCEDURES

General	4-8	Air Cleaner Elements	
Housing Replacement	4-9	Replacement	4-20
Housing Repair	4-10	Carburetor Replacement	4-21
Wiring Harness Repair	4-11	Intake Manifold Assembly	
Toggle Switch S3		Replacement	4-22
Replacement	4-12	Starter Panel Assembly	
Water Pump Drivebelt		Replacement/Repair	4-23
Replacement	4-13	Sparkplugs Replacement	4-24
Compressor Drivebelt		Armature Group	
Replacement	4-14	Replacement/Repair	4-25
Fan Assembly Replacement	4-15	Dipstick and Tube Assembly	
Pulley Drive (Used on all		Replacement/Repair	4-26
water chillers Model LCW-2685 only)		Starter Replacement	4-27
Replacement/Repair	4-16	Flywheel and Ring Gear	
Centrifugal Clutch		Assembly Replacement/	
(Model LCC-2685 only)		Repair	4-28
Replacement/Repair	4-17	High Pressure Switch	
Exhaust System		Continuity Test	4-29
Replacement/Repair	4-18	Low Pressure Switch	
Engine Assembly		Continuity Test	4-30
Replacement/Repair	4-19	Water Pump Replacement	4-31

Section V. UNIT MAINTENANCE PROCEDURES (CONT)

	Para		Para
High Temperature Thermal		Skid Repair	4-36
Switch Replacement	4-32	Trailer Mounting Kit Repair	4-37
Relief Valve Repair	4-33	Modified Trailer Mounting	
Low Temperature Thermal Switch Test ..	4-34	Kit Repair	4-38
Vehicle Receptacle		Support Kit Repair	4-39
Assembly Replacement	4-35		

Section VI. PREPARATION FOR STORAGE OR SHIPMENT

Storage and Shipment Instructions . . .4-40

Section I. REPAIR PARTS; SPECIAL TOOLS; TEST, MEASUREMENT, AND DIAGNOSTIC EQUIPMENT (TMDE); AND SUPPORT EQUIPMENT

- 4-1. COMMON TOOLS AND EQUIPMENT.** For authorized common tools and equipment, refer to modified table of organization and equipment (MTOE) applicable to your unit.
- 4-2. SPECIAL TOOLS, TMDE, AND SUPPORT EQUIPMENT.** Refer to the Repair Parts and Special Tools List (RPSTL), appendix F, or the Maintenance Allocation Chart (MAC), appendix B.
- 4-3. REPAIR PARTS.** Repair parts are listed and illustrated in the RPSTL, TM 10-4130-237-24P.

Section II. SERVICE UPON RECEIPT**4-4. UNPACKING AND INSPECTION**

a. General. The basic water chiller, support kit, and trailer mounting kit are crated and shipped as one item. Support kit and trailer mounting kit are boxed together on top of the water chiller.

b. Unpacking the Water Chiller

- 1 Place crated unit as close as possible to point of use.
- 2 Remove steel bands from top of crate, being careful not to damage water chiller components.
- 3 Remove cardboard box containing kits from top of water chiller. (Instructions are also on box.)
- 4 Open cardboard box and remove contents.
- 5 Inspect all contents for damage.

NOTE

- The cardboard box contains a duffle bag for storing components of support kit after removal from packing box. Select components required for installation from support kit. Store spare support kit components in duffle bag for later use.
- Check contents using appendix C, Components of End Item and Basic Issue Items Lists.

- 6 Check support kit contents. These items are required for setting up water chiller as operational unit.
- 7 Check contents of trailer mounting kit. Do not remove from shipping ease until ready for installation.
- 8 Remove crating from around water chiller and remove hold-down bolts from skid base.
- 9 Remove water chiller from crating and place at point of operation.

4-4. UNPACKING AND INSPECTION (CONT)

- c. Inspection Upon Receipt of Shipment. Inspect water chiller for loose or missing screws and fasteners and for bent, dented, cracked, or broken components. Inspect air intakes/grills for debris and damage. Perform monthly (M) preventive maintenance checks and services (PMCS).

Section III. UNIT PREVENTIVE MAINTENANCE CHECKS AND SERVICES (PMCS)

4-5. GENERAL

- a. Always keep in mind the CAUTIONS and WARNINGS while performing PMCS.
- b. Report any deficiencies using the proper forms. See DA Pam 738-750.
- c. If the PMCS table requires removal of assemblies or equipment, refer to the maintenance procedures section of this chapter.

4-6. PMCS PROCEDURES

- a. Purpose. The PMCS table lists the inspections and care of the equipment required to keep it in good operating condition.
- b. Use. To perform PMCS, follow the directions listed for each column below.

(1) Item No. This column numbers the checks and services in order of performance. It is the source of item numbers for the TM Number Column on DA Form 2404, Equipment Inspection and Maintenance Worksheet.

(2) Interval. This column tells you when to do a certain check or service. The codes in this column are as follows:

W – Perform these checks and services once per week.

M – Perform these checks and services once per month and upon receipt of new equipment.

H – Perform these checks and services after the number of hours of equipment operation listed in the column.

4-6. PMCS PROCEDURES (CONT)

(3) Item to be Inspected Procedure. This column tells you what item is to be inspected. It also tells you how to do the required checks and services. Carefully follow these instructions. If directed by the procedure, or if you do not have the required tools, have direct support maintenance do the work.

c. Housing Removal/Reinstallation. Before performing PMCS, remove muffler and housing. After PMCS, reinstall housing and muffler. (See paragraphs 4-9 and 4-17.)



Table 4-1. Unit Preventive Maintenance Checks and Services (PMCS)

Note: If the Water Chiller must be kept in continuous operation, check and service only those items that can be checked and serviced without disturbing operation. Make the complete checks and services when the equipment can be shut down.

ITEM NO.	INTERVAL	ITEM TO CHECK/SERVICE	CREWMEMBER/PROCEDURE	NOT FULLY MISSION CAPABLE IF:
1.	Weekly	Carburetor	 <p>a. Remove air cleaner element and air cleaner housing (para 4-19).</p> <p>b. Check for loose mounting bolts.</p> <p>c. Check for cracks.</p> <p>d. Check fuel pump for loose mounting screws or cracks.</p>	<p>Fuel or vacuum lines leaking.</p> <p>Mounting bolts loose.</p> <p>Carburetor cracked.</p> <p>Fuel pump cracked or loose.</p>

Table 4-1. Unit Preventive Maintenance Checks and Services (PMCS) (Continued)

ITEM NO.	INTERVAL	ITEM TO CHECK/SERVICE	CREWMEMBER/PROCEDURE	NOT FULLY MISSION CAPABLE IF:
2.	Weekly	Starter	 <p>Check for loose mounting bolts and cable connection.</p>	Mounting bolts or cable connection loose.
3.	Weekly	Governor Assembly	 <p>Check for loose mounting bolts and damage to governor lever and springs.</p>	Mounting bolts loose or damage to governor lever or springs.

Table 4-1. Unit Preventive Maintenance Checks and Services (PMCS) (Continued)

ITEM NO.	INTERVAL	ITEM TO CHECK/ SERVICE	CREWMEMBER/ PROCEDURE	NOT FULLY MISSION CAPABLE IF:
4.	Weekly	Engine	 <p>PULLEY</p> <p>COMPRESSOR</p> <p>MOUNTING BOLT</p> <ol style="list-style-type: none"> Check for leaks at engine base gasket, front and rear crank case cover gaskets, and left and right breather assembly gaskets. Check for loose mounting bolts and cracks. 	<p>Engine Leaks</p> <p>Engine cracked or loose mounting bolts.</p>
			 <p>REAR CRANKCASE COVER MOUNTING BOLT</p> <p>BREATHER ASSEMBLY MOUNTING BOLTS</p> <p>ENGINE BASE GASKET</p> <p>ENGINE BASE MOUNTING BOLTS</p>	
5.	Weekly	Condenser	Inspect condenser for dirt, debris and clogging.	Condenser clogged.

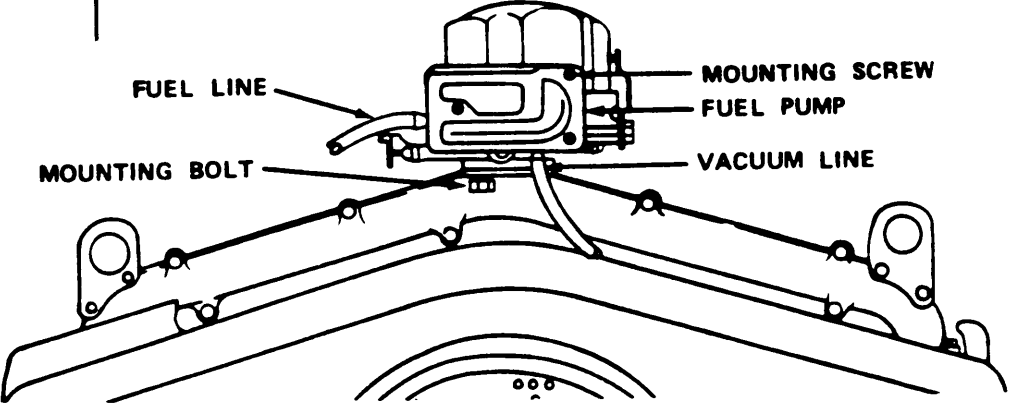
Table 4-1. Unit Preventive Maintenance Checks and Services (PMCS) (Continued)

ITEM NO.	INTERVAL	ITEM TO CHECK/ SERVICE	CREWMEMBER/ PROCEDURE	NOT FULLY MISSION CAPABLE IF:
6.	Weekly	Strainer	 <p>Inspect and clean strainer.</p>	Strainer clogged.
7.	Monthly	Compressor	 <p>Check for unusual noise, leaks irregular pulley motion and loose mounting bolts.</p>	Compressor is loose, leaking, noisy or has irregular pulley motion.

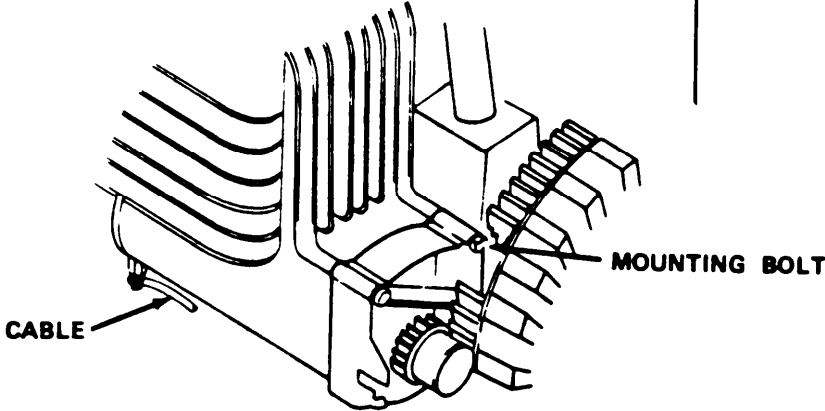
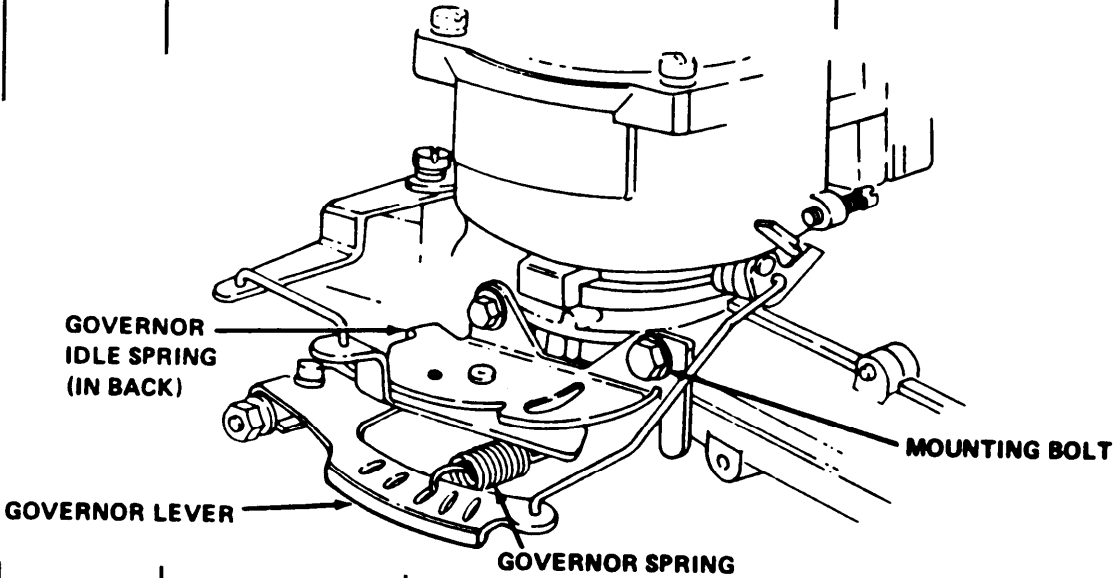
Table 4-1. Unit Preventive Maintenance Checks and Services (PMCS) (Continued)

ITEM NO.	INTERVAL	ITEM TO CHECK/SERVICE	CREWMEMBER/PROCEDURE	NOT FULLY MISSION CAPABLE IF:
8.	Monthly	Water Pump.	 <p>Check for cracks, leaks, and loose mounting bolts.</p>	Water pump leaking, cracked or is loose.
9.	Monthly	Spark Plugs.	 <p>Check for cracks, burning and fouling. Remove and clean after 200 hrs of operation or monthly whichever comes first.</p>	Cracked, burnt or fouled plugs.

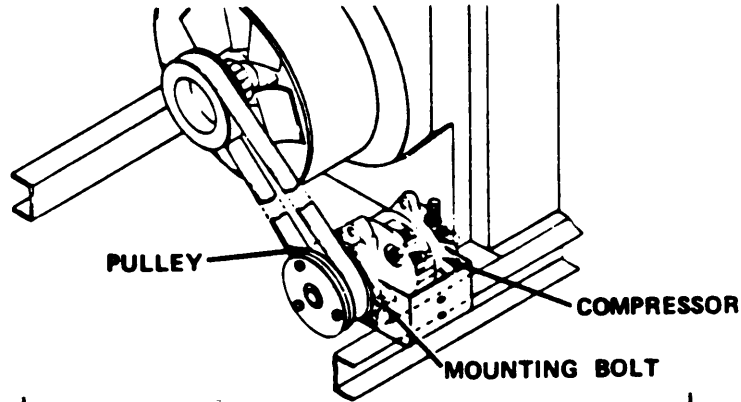
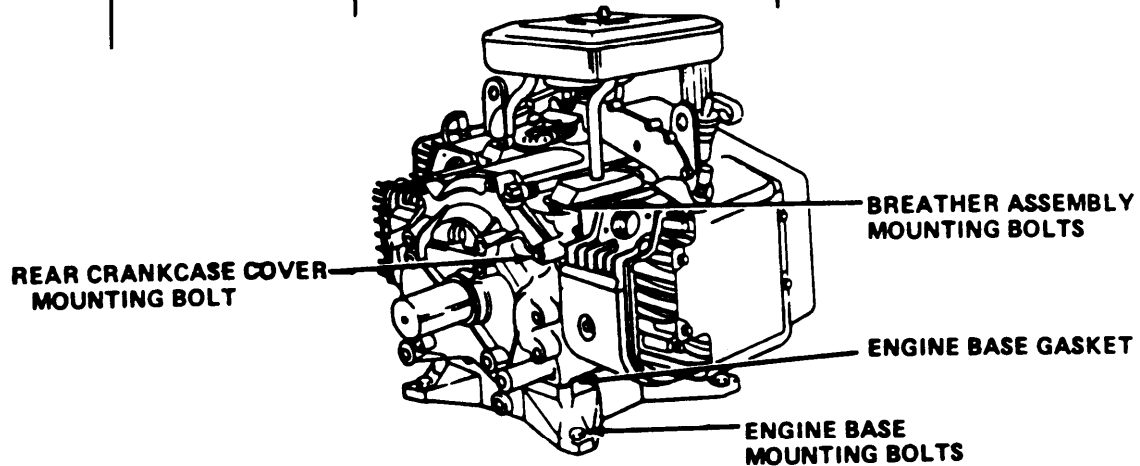
Section IV. UNIT TROUBLESHOOTING

4-7. **UNIT TROUBLESHOOTING.** Table 4-2, Troubleshooting, lists common malfunctions which may be found during normal operation or during an inspection, check procedure, or scheduled testing. Perform the tests/inspections and corrective actions in order listed. This manual cannot list all malfunctions that may occur or list all tests/inspections and corrective actions. If a malfunction occurs that is not listed or covered in corrective action, notify your supervisor.

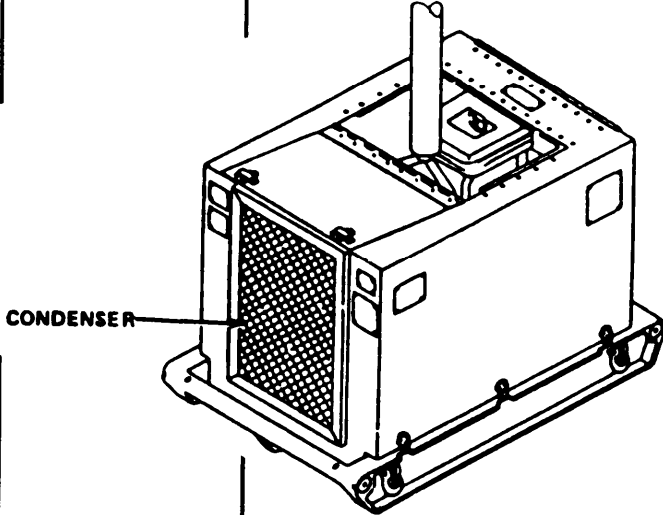
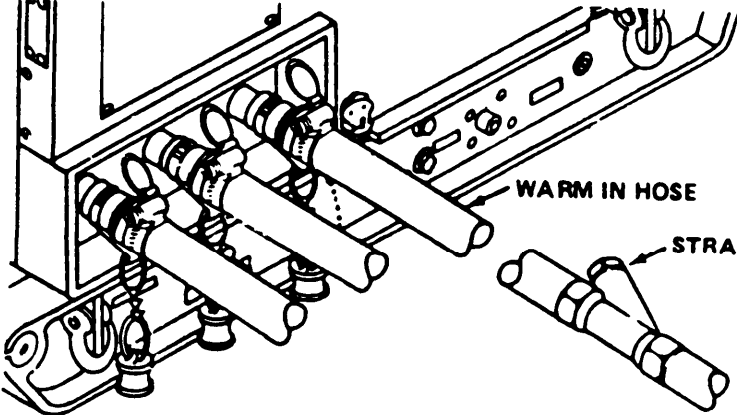
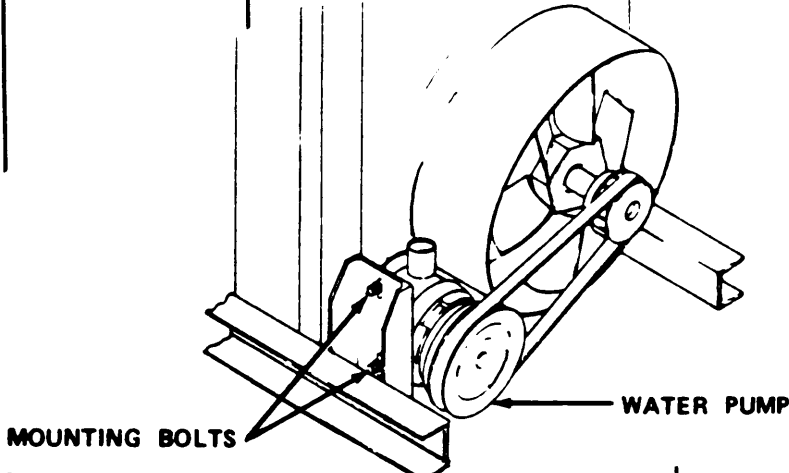
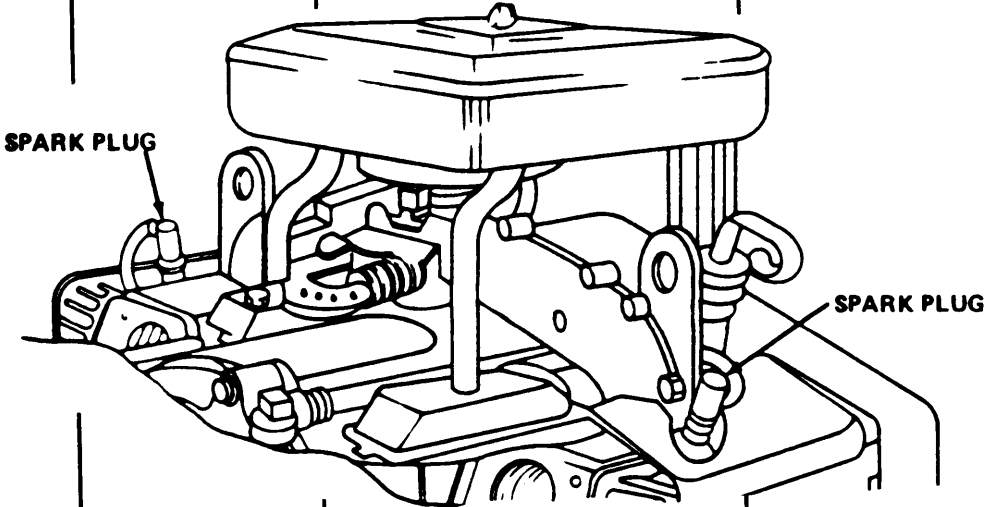
Table 4-2. Troubleshooting

MALFUNCTION	TEST OR INSPECTION	CORRECTIVE ACTION
-------------	--------------------	-------------------

1. ENGINE FAILS TO START WITHOUT EXTERNAL POWER OR CRANKS BUT FAILS TO START WITH EXTERNAL POWER.

Step 1. Disconnect wiring harness, wire number 4, from toggle switch S3, terminal number 2. Try to start water chiller engine (para 2-6).

If engine starts, turn engine off and reconnect wiring harness, wire number 4 to toggle switch S3, terminal number 2. Check high and low pressure switches and wiring harness for continuity (paras 4-29, 4-30 and 4-11). If switches and wiring harness have continuity, notify Direct Support to check refrigeration.

If engine does not start, proceed with steps 2 through 8 below until engine malfunction has been corrected and engine starts. Reconnect wiring harness, wire number 4, to toggle switch S3, terminal number 2, and restart engine. Check high and low pressure switches and wiring harness for continuity (paras 4-29, 4-30 and 4-11). If switches and wiring harness have continuity, notify Direct Support to check refrigeration.

Step 2. Check to see if water supply temperature is below 60°F (16°C) or above 120°F (49°C).

Water chiller is not designed to run if water supply temperature is below 60°F (16°C) or above 120°F (49°C). Do not run water chiller until proper conditions exist.

Step 3. Check fuel line and fuel filter for damage or blockage.

Repair fuel line or replace fuel falter (para 4-39).

Step 4. Check spark plugs for fouling or damage.

Clean or replace spark plugs (para 4-24).

Step 5. Check carburetor for damage, blockage, or proper adjustment.

Replace or adjust carburetor (para 4-21).

Step 6. Test toggle switch S3 (para 4-12).

Replace toggle switch S3 (para 4-12).

Table 4-2. Unit Troubleshooting (Cont)

MALFUNCTION

TEST OR INSPECTION

CORRECTIVE ACTION

Step 7. Test armature group (para 4-25).

Replace armature group (para 4-25).

Step 8. Check engine compression (para 4-19). Should not vary more than 25 percent between cylinders.

If greater than 25 percent variance, notify your supervisor.

2. ENGINE FAILS TO CRANK WITH EXTERNAL POWER.

Step 1. Check for proper voltage to 12/24 VOLT INPUT FOR STARTING connection. Obtain proper voltage.

Step 2. Check for proper voltage at back of 12/24 VOLT INPUT FOR STARTING connection (para 4-34).

If voltage incorrect, replace connection (para 4-35).

Step 3. Test starter button S7 for voltage (para 4-23).

Replace starter button S7 (para 4-23).

Step 4. Check for proper voltage at starter (para 4-27).

Replace starter cable or starter (para 4-27).

Step 5. Check ring gear for damage (para 4-28).

Replace ring gear (para 4-28). If problem not corrected, notify your supervisor.

3. ENGINE STOPS SUDDENLY.

Step 1. Check to see if water supply temperature is below 60°F (16°C) or above 120°F (49°C).

Water chiller is not designed to run if water supply temperature is below 60°F (16°C) or above 120°F (49°C). Do not run water chiller until proper conditions exist.

Table 4-2. Unit Troubleshooting (Cont)

MALFUNCTION	TEST OR INSPECTION	CORRECTIVE ACTION
-------------	--------------------	-------------------

3. ENGINE STOPS SUDDENLY (CONT)

Step 2. Test high temperature thermal switch for continuity (para 4-32).

Replace switch (para 4-32).

Step 3. Check for loose or broken compressor drivebelt.

Adjust or replace compressor drivebelt (para 4-14).

Step 4. Test high and low pressure switches and low temperature thermal switch for continuity (para 4-29,4-30, and 4-33).

If any switch fails test, notify your supervisor.

4. LOW ENGINE SPEED.

Step 1. Check for dirty air filter elements.

Clean or replace air falter elements (para 34, 3-5, or 4-19).

Step 2. Check carburetor adjustment.

Adjust or replace carburetor (para 4-21). If problem not corrected, notify your supervisor.

5. PRODUCT WATER NOT COOL.

Step 1. Check REFRIGERANT SIGHT GLASS for bubbles or milky white liquid.

If bubbles or milky white liquid present, notify your supervisor.

Step 2. Check engine speed (MALFUNCTION 4).

If problem not corrected, notify your supervisor.

Table 4-2. Unit Troubleshooting (Cont)

MALFUNCTION
TEST OR INSPECTION
CORRECTIVE ACTION

6. LOW OUTLET WATER PRESSURE.

Step 1. Check water hoses for leaks or blockage.

Repair or replace hose (para 4-39).

Step 2. Check for loose or broken water pump drivebelt.

Adjust or replace water pump drivebelt (para 4-13).

Step 3. Check water pump for proper operation,

Replace water pump (para 4-31).

Step 4. Check engine speed (MALFUNCTION 4).

If problem not corrected, notify your supervisor.

Section V. UNIT MAINTENANCE PROCEDURES

4-8. GENERAL

a. Scope. This section contains unit maintenance instructions authorized by the Maintenance Allocation Chart (MAC), appendix B, and by the source, maintenance, and recoverability (SD) coded items to support the water chiller.

b. Equipment Conditions. Unless otherwise specified, perform all maintenance under the following conditions:

- 1 Engine stopped.

4-8. GENERAL (CONT)

WARNING

To prevent electric shock, be very careful when disconnecting power from 12/24 VOLT INPUT FOR STARTING connection.

- Power disconnected from 12/24 VOLT INPUT FOR STARTING connection.

Fuel is flammable. To prevent fire or explosion, DO NOT bring sparks or open flame near fuel line.

- Fuel line disconnected.
- Muffler (para 4-18) and housing (para 4-9) removed.

After performing maintenance:

- Install housing (para 4-9) and muffler (para 4-18).
- If necessary, reconnect power cable to 12/24 VOLT INPUT FOR STARTING connection.

4-9. HOUSING REPLACEMENT

This task covers:

a. Removal

b. Installation

INITIAL SETUP

Equipment

Condition

<u>Para</u>	<u>Condition Description</u>
4-8	Engine stopped, power disconnected, fuel line disconnected, muffler and housing removed.

Personnel Required

Two to lift housing.

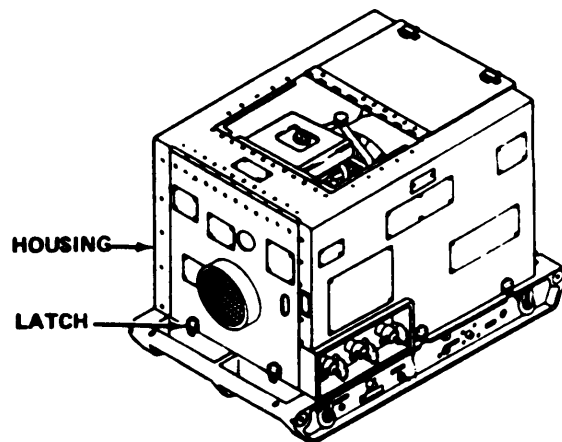

4-9. HOUSING REPLACEMENT (CONT)

a. Removal

- 1 Turn nine latches left to lengthen. Pull away from slot. Turn right to shorten to prevent catching on slot.
- 2 With one person at each end, slowly lift housing. Tilt as needed to clear engine and condenser. Remove housing.

b. Installation

- 1 With one person at each end, slowly lower housing over water chiller. Tilt (as needed to clear engine and condenser).
- 2 Fasten nine latches.

4-10. HOUSING REPAIR

This task covers repair only.

INITIAL SETUP

Equipment
Condition

Para

Condition Description

Tools

4--8

Engine stopped, power disconnected, fuel line disconnected, muffler and housing removed.

Common No. 1 Organizational Maintenance Automotive Maintenance and Repair Shop Eqpt, item 2, appendix B

Materials/Parts

Tags, item 22, appendix E

General Mechanic's Tool Kit, item, appendix B

NOTE

Repair of the housing consists of replacement of defective rivets, top and side latches, data plates, and rubber stripping.

4-10. HOUSING REPAIR (CONT)

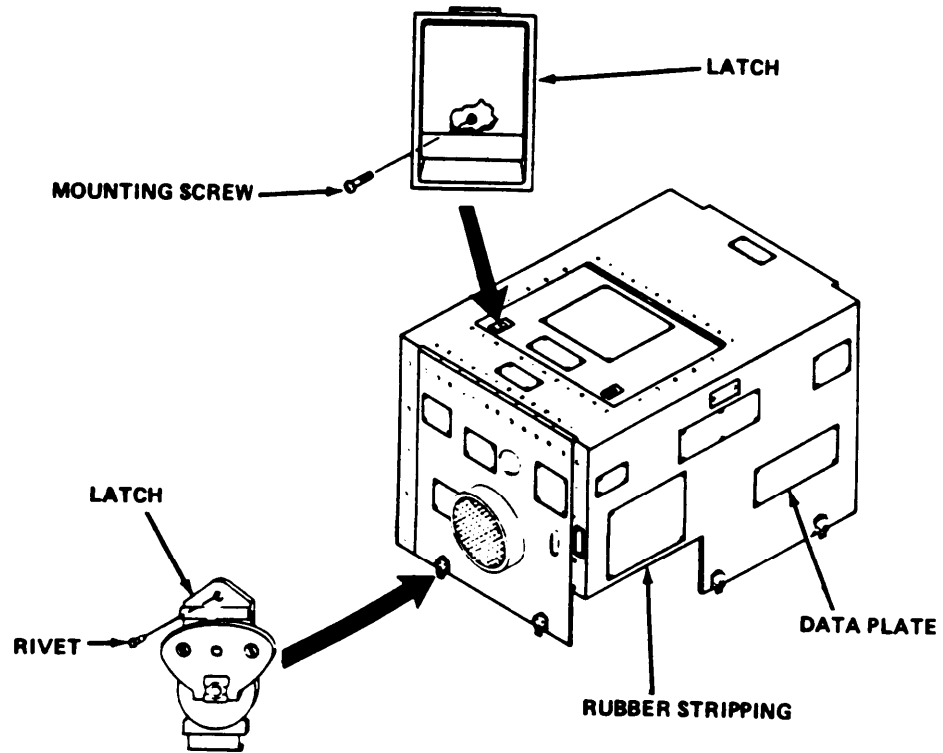

a. Replacement of Side Latches and Rivets

- 1 Cut off rivets. Remove latch (if replacing it).
- 2 Install latch. Insert correct size rivet. Hammer rivet tight.

b. Replacement of Top Latches

- 1 Hold top latch in open position. Remove mounting screw and bracket. Remove top latch.
- 2 Hold top latch in open position. Install mounting screw through top latch into bracket.

4-10. HOUSING REPAIR (CONT)

c. Replacement of Data Plates

1 Drill out existing rivets on data plate. Remove data plate from housing.

2 Install data plate on housing. Aline mounting holes.

3 Install pop rivets in mounting holes.

d. Replacement of Rubber Stripping

1 Remove existing rubber stripping.

2 Cut new stripping to correct length. Install stripping with adhesive side against housing. Trim any excess.

4-11. WIRING HARNESS REPAIR

This task covers:

a. Testing

b. Repair

INITIAL SETUP

Equipment

Condition

Para

Condition Description

Tools

4-8

Engine stopped, power disconnected, fuel line disconnected, muffler and housing removed.

Common No. 1 Organizational Maintenance Automotive Maintenance and Repair shop Eqpt item 2, appendix B

General Mechanic's Tool Kit, item 1, appendix B

4-11. WIRING HARNESS REPAIR (CONT)

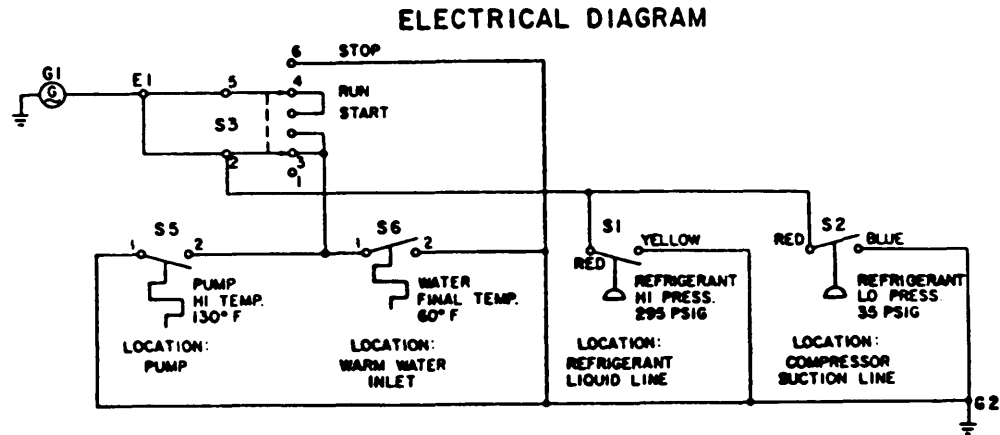

a. Testing

- 1 Prepare multimeter for continuity test.
- 2 Place red lead on one end of wire section to be tested. Place black lead on other end of wire section to be tested.
- 3 Multimeter should display less than 1 ohm. If it does not display less than 1 ohm, replace wire.

b. Repair

NOTE

Repair of wiring harness consists of replacement of defective wire.

- 1 Unwrap harness cover as needed. Remove damaged wire from wiring harness.

4-11. WIRING HARNESS REPAIR (CONT)

2 Cut correct length of wire from bulk wire. (See table below.) Crimp terminal to each end of wire.

Wire Number	Wire Location		Wire Length	
	From	To	in.	(cm)
1	S3-2	E1	12.5	(32)
2	S3-3	S6-1	30	(76)
3	S3-2	S3-5	4	(10)
4	S3-2	S2-RED	32	(81)
5	S3-6	S6-2	30	(76)
6	S2-RED	S1-RED	19	(48)
7	S2-BLU	S1-YEL	15	(38)
8	S1-YEL	S5-1	20	(51)
9	S3-3	S5-2	57	(145)
10	S5-1	GND 2	19	(48)

3 Install wire in wiring harness. Rewrap cover as needed.

4-12. TOGGLE SWITCH S3 REPLACEMENT

This task covers:

- a. Testing
- b. Removal
- c. Installation

INITIAL SETUP

Equipment
Condition

<u>Para</u>	<u>Condition Description</u>	<u>Tools</u>
4-8	Engine stopped, power disconnected, fuel line disconnected, muffler and housing removed.	Common No. 1 Organizational Maintenance Automotive Maintenance and Repair Shop Eqpt, item 2 appendix B

Materials/Parts

Tags, item 22, appendix E

4-12. TOGGLE SWITCH S3 REPLACEMENT (CONT)

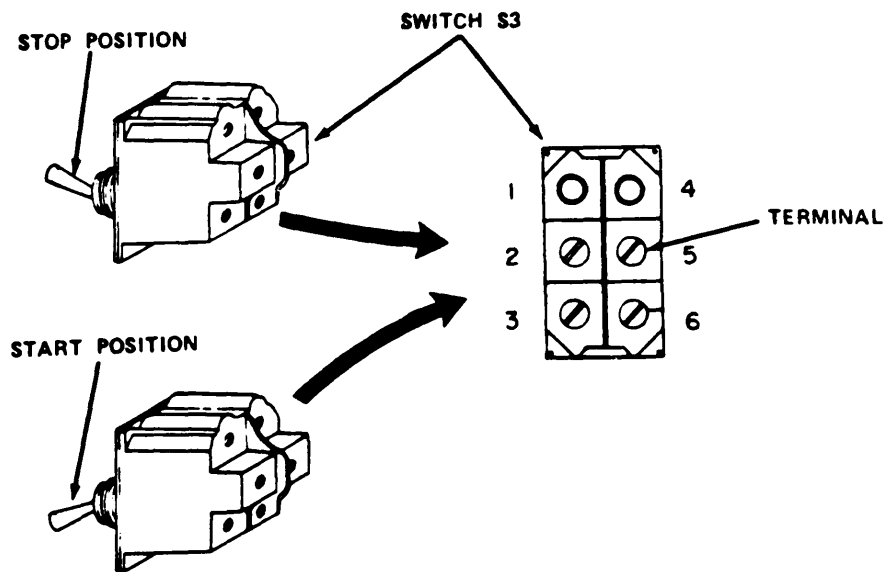
a. Testing

- 1 Tag and remove eight wires from back of switch.
- 2 Prepare multimeter for continuity test. Place red lead on terminal 5 and black lead on terminal 6.
- 3 If multimeter shows less than 1 ohm, replace switch.
- 4 Hold switch S3 in STOP position. Place red lead on terminal 5 and black lead on terminal 6.
- 5 If multimeter shows greater than 1 ohm, replace switch.
- 6 Hold switch S3 in START position. Place red lead on terminal 2 and black lead on terminal 3.
- 7 If multimeter shows less than 1 ohm, replace switch.
- 8 If switch passes test, reinstall eight wires on back of switch. Remove tags.

4-12. TOGGLE SWITCH S3 REPLACEMENT (CONT)

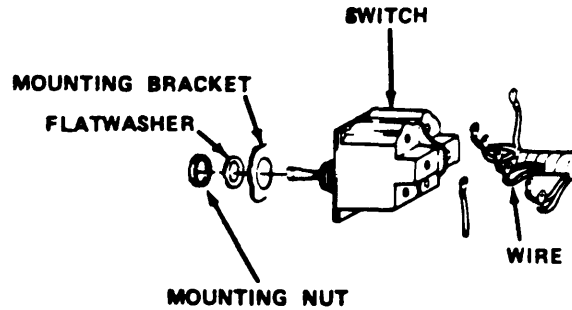

b. Removal

- 1 Tag and remove eight wires from back of switch.
- 2 Remove mounting nut and flatwasher.
- 3 Remove switch from mounting bracket.

c. Installation

- 1 Install switch in mounting bracket.
- 2 Install flatwasher and mounting nut.
- 3 Install eight wires on back of switch. Remove tags.

4-13. WATER PUMP DRIVEBELT REPLACEMENT

This task covers:

a. Removal

b. Installation and Adjustment

INITIAL SETUP

Tools

Equipment

Condition

Para

Condition Description

Tools

4-8

Engine stopped, power disconnected, fuel line disconnected, muffler and housing removed.

General Mechanic's Tool Kit, item 1, appendix B

4-13. WATER PUMP DRIVEBELT REPLACEMENT (CONT)

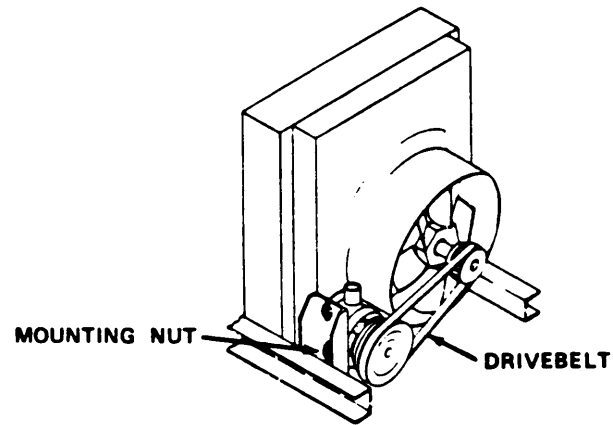

a. Removal

- 1 Loosen two mounting nuts.
- 2 Lift water pump, sliding mounting bolts up in holes.
- 3 Remove drivebelt from water pump pulley and pulley drive. Lift over fan to remove.

b. Installation and Adjustment

- 1 Install drivebelt on pulley drive and water pump pulley.
- 2 Push down on water pump, sliding bolts down in holes.
- 3 Adjust drivebelt to proper tension, about 1/4-inch (2/3-centimeter) deflection at center of belt.
- 4 Tighten mounting nuts.

4-14. COMPRESSOR DRIVEBELT REPLACEMENT

This task covers:

- a. Removal
- b. Inspection (Pulley Drive)
- c. Installation and Adjustment

INITIAL SETUP

Equipment

Condition

<u>Para</u>	<u>Condition Description</u>	<u>Tools</u>
4-8	Engine stopped, power disconnected, fuel line disconnected, muffler and housing removed.	General Mechanic's Tool Kit, item 1, appendix B
4-13	Water pump drivebelt removed.	

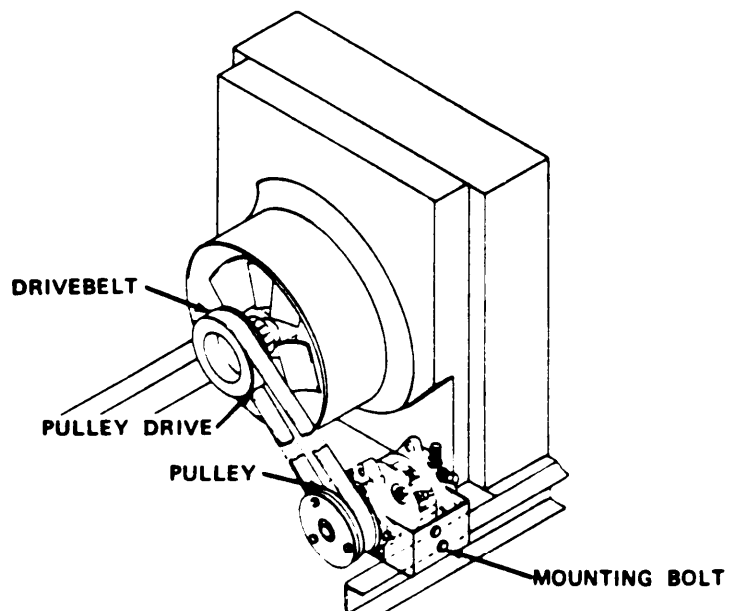

a. Removal

- 1 Loosen two bracket mounting bolts.
- 2 Lift compressor, sliding bracket mounting bolts up in holes.
- 3 Remove drivebelt from compressor pulley and pulley drive. Lift belt over fan to remove.

4-14. COMPRESSOR DRIVEBELT REPLACEMENT (CONT)

b. Inspection (Pulley Drive)

- 1 With belt removed, inspect pulley drive or centrifugal clutch for wear and damage.
- 2 If pulley drive or centrifugal clutch is worn or damaged, replace it (para 4-16 or 4-17).

c. Installation and Adjustment

- 1 Install drivebelt on pulley drive and compressor pulley.
- 2 Push down on compressor, sliding bracket mounting bolts down in holes.
- 3 Adjust drivebelt to proper tension, about 1/4-inch (2/3-centimeter) deflection at center of belt.
- 4 Tighten two bracket mounting bolts.
- 5 Install water pump drivebelt (para 4-13).

4-15. FAN ASSEMBLY REPLACEMENT

This task covers:

- a. Removal
- b. Installation

INITIAL SETUP

Equipment
Condition

<u>Para</u>	<u>Condition Description</u>	<u>Tools</u>
4-8	Engine stopped, power disconnected, fuel line disconnected, muffler and housing removed.	General Mechanic's Tool Kit, item 1, appendix B
4-19	Engine removed.	

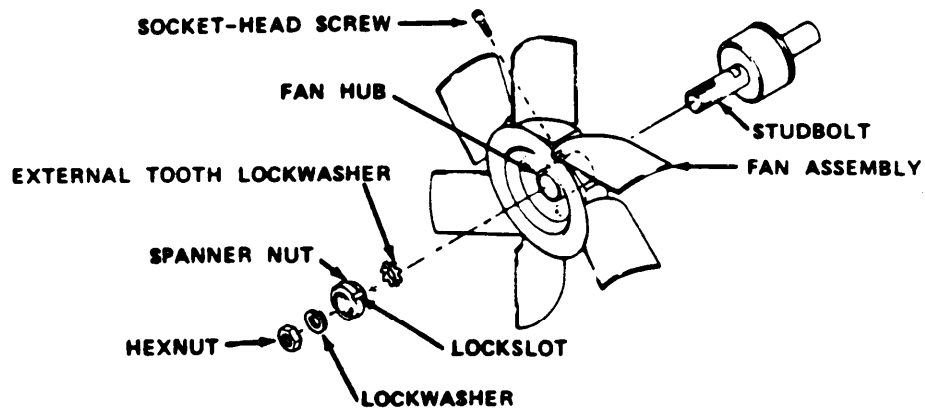

4-15. FAN ASSEMBLY REPLACEMENT (CONT)

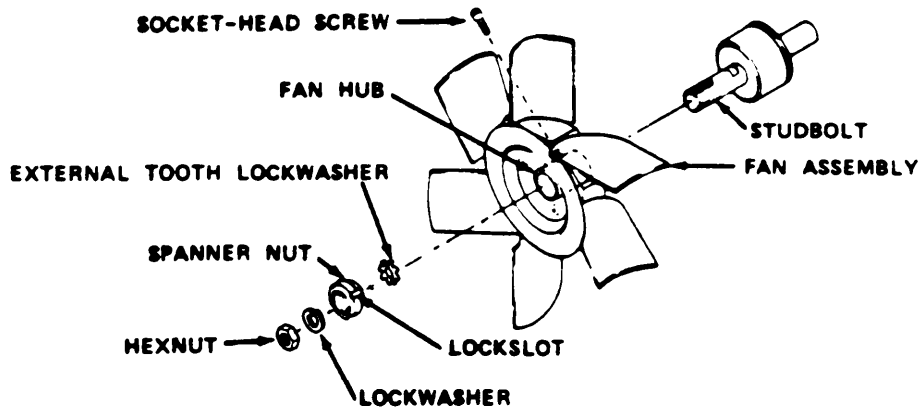

a. Removal

- 1 Remove hexnut and lockwasher from studbolt.
- 2 Bend ear of external tooth lockwasher away from spanner nut.
- 3 Remove spanner nut and external tooth lockwasher from studbolt.
- 4 Loosen socket-head screw on back of fan hub.
- 5 Remove fan assembly.

b. Installation

- 1 Install fan assembly on studbolt.

NOTE

Make sure that ear of lockwasher aligns with lock-slot on spanner nut.

- 2 Install external tooth lockwasher and spanner nut on studbolt.
- 3 Bend ear of external tooth lockwasher into slot on spanner nut.
- 4 Tighten socket-head screw on back of fan hub.
- 5 Install lockwasher and hexnut on stud and bolt .
- 6 Install engine (para 4-19).

4-16. PULLEY DRIVE REPLACEMENT/REPAIR. (Applicable to Models LCW 2685 only).

This task covers:

- a. Disassembly
- b. Assembly

INITIAL SETUP

Equipment

Condition

<u>Para</u>	<u>Condition Description</u>	<u>Tools</u>
4-8	Engine stopped, power disconnected, fuel line disconnected, muffler and housing removed.	General Mechanic's Tool Kit, item 1, appendix B
4-19	Engine removed.	
4-15	Fan assembly removed.	

NOTE

During disassembly of the pulley drive, inspect parts for wear and damage. Repair of the pulley drive consists of replacement of defective parts.

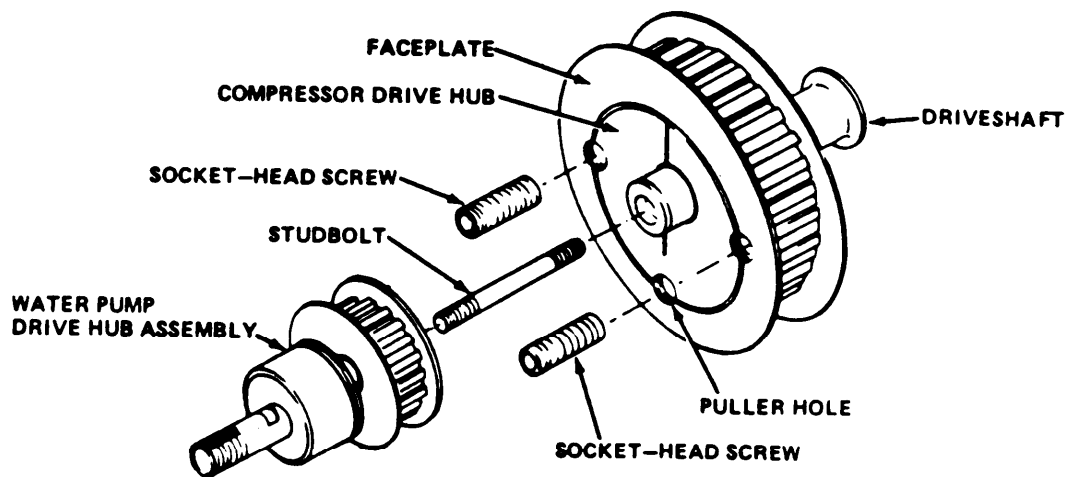

a. Disassembly

- 1 Remove water pump drive hub assembly.
- 2 Unscrew threaded studbolt from end of engine driveshaft.
- 3 Remove two socket-head screws from compressor drive hub.

4-16. PULLEY DRIVE REPLACEMENT/REPAIR (CONT)

- 4 Install socket-head screw in puller hole in compressor drive hub. Tighten socket-head screw while gently tapping on outer part of faceplate.
- 5 Tighten screw and continue tapping, until faceplate can be pushed back toward engine and free of center hub.

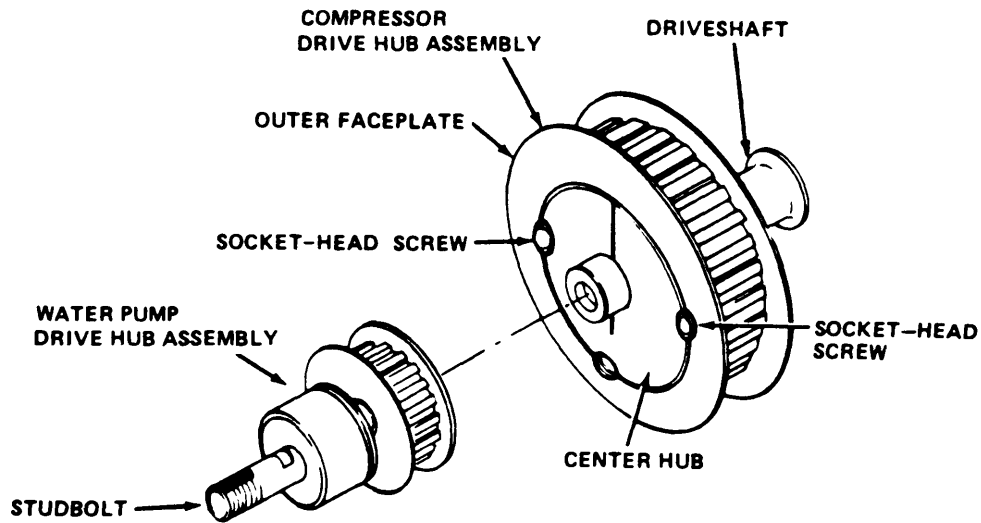

- 6 Remove center hub and locking key from driveshaft.
- 7 Remove faceplate from driveshaft.

b. Assembly

NOTE

Side of faceplate with three screws faces away from engine.

- 1 Place faceplate on driveshaft against engine.
- 2 Place locking key in slot on driveshaft.
- 3 Aline center hub with locking key. Install center hub on end of driveshaft.

4-16. PULLEY DRIVE REPLACEMENT/REPAIR. (CONT)

4 While sliding center hub back on driveshaft, place faceplate loosely on center hub.

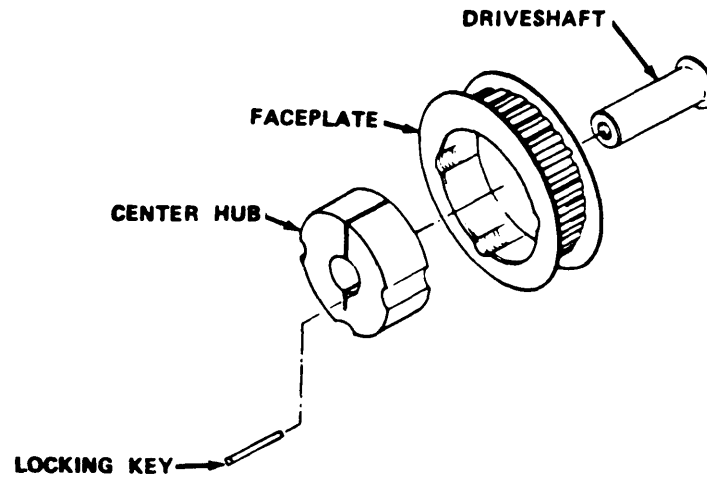

- 5 Push compressor drive hub assembly back against engine. Adjust to provide clearance of about 3/16 in. (1/2 cm) between assembly and engine.
- 6 Install studbolt in driveshaft.
- 7 Install water pump drive hub assembly on driveshaft.
- 8 Install fan assembly (para 4-15).
- 9 Install engine (para 4-19).

4-17 CENTRIFUGAL CLUTCH REPLACEMENT/REPAIR. (Applicable to Model LCC-2685 only).

This task covers:

a. Disassembly

b. Assembly

INITIAL SETUP

Equipment

Condition

<u>Para</u>	<u>Condition Description</u>	<u>Tools</u>
4-8	Engine stopped, power disconnected, fuel line disconnected, muffler and housing removed.	General Mechanic's Tool Kit, item 1, appendix B
4-19	Engine removed.	Shop Equipment Automotive: Maintenance and Repair Organizational Common #1, item 2, appendix B
4-15	Fan assembly removed.	Puller Adapter. appendix F

NOTE

During disassembly, inspect parts for wear and damage. Repair consists of replacement of defective parts.

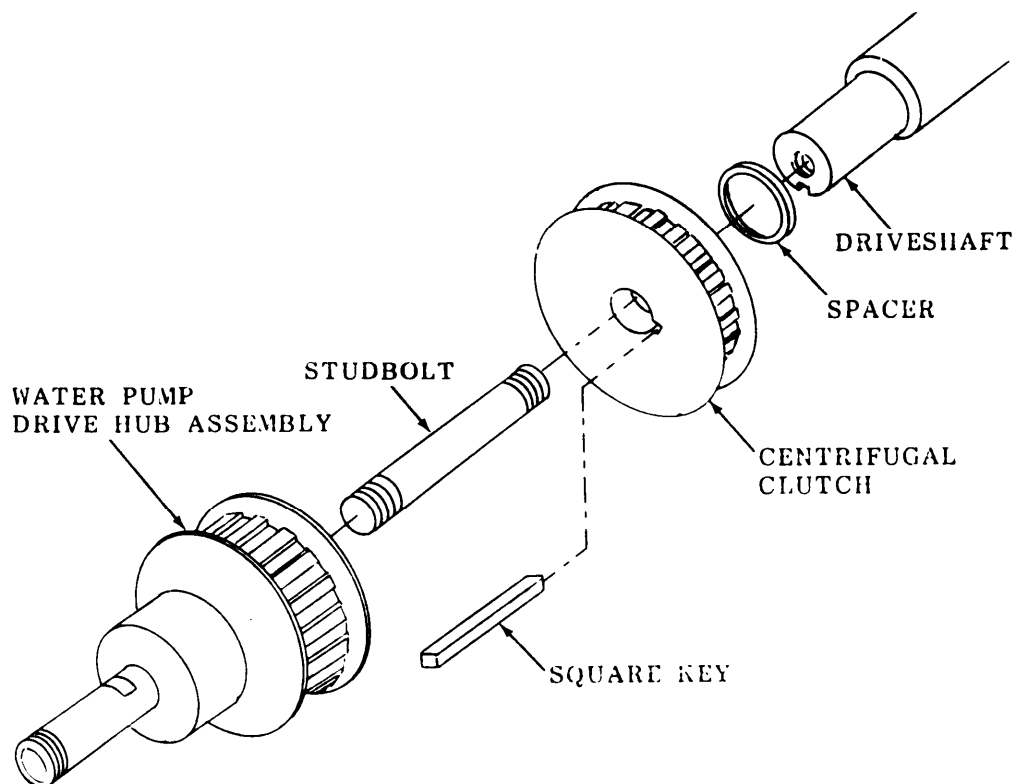

4-17. CENTRIFUGAL CLUTCH REPLACEMENT/REPAIR (CONT)**a. Disassembly**

- 1** Using drive hub assembly adapter and puller, remove drive hub assembly.
- 2** Unscrew threaded studbolt from end of engine driveshaft.
- 3** Remove centrifugal clutch from driveshaft.
- 4** Remove square key and spacer from driveshaft.

b. Assembly

- 1** Place spacer on driveshaft against the shoulder.
- 2** Replace the driveshaft square key and install the centrifugal clutch (recessed area first) on the driveshaft.
- 3** Screw the studbolt into the driveshaft end.
- 4** Install water pump drive hub assembly.
- 5** Install fan assembly (para 4-15).
- 6** Install engine (para 4-19).

4-18. EXHAUST SYSTEM REPLACEMENT/REPAIR

This task covers:

a. Removal

b. Installation

INITIAL SETUP

Equipment

Condition

<u>Para</u>	<u>Condition Description</u>	<u>Tools</u>
4-8	Engine stopped, power disconnected, fuel line disconnected, housing removed.	Common No. 1 Organizational Maintenance Automotive Maintenance and Repair Shop Eqpt, item 2, appendix B

NOTE

Repair of the exhaust system consists of replacement of the muffler, manifold, or gaskets. During disassembly, inspect muffler and manifold for wear and damage. Replace if worn or damaged. Always replace gaskets.

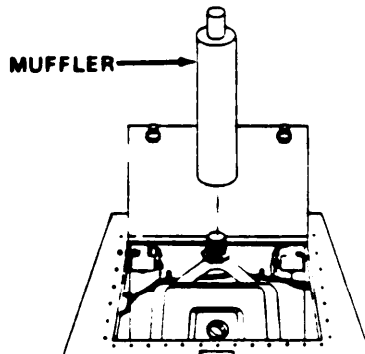

a. Removal

WARNING

To prevent burns, DO NOT try to remove muffler until it cools down.

1 Remove muffler.

4-18. EXHAUST SYSTEM REPLACEMENT/REPAIR (CONT)

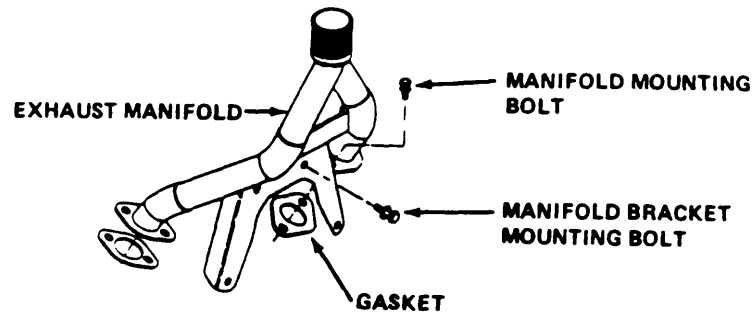

- 2 Remove four exhaust manifold mounting bolts.
- 3 Remove four exhaust manifold bracket mounting bolts.
- 4 Remove exhaust manifold and two gaskets. Discard gaskets.

b. Installation

- 1 Install two exhaust manifold gaskets on engine.
- 2 Install exhaust manifold on gaskets.

CAUTION

To prevent damage to manifold, be sure to install all bolts by hand before tightening. Tighten in order listed.

- 3 Install four exhaust manifold mounting bolts. Hand-tighten.
- 4 Install four exhaust manifold bracket mounting bolts. Hand-tighten.
- 5 Tighten four exhaust manifold mounting bolts.
- 6 Torque four exhaust manifold bracket mounting bolts to 140 in. lb (15.8 Nm).

4-19. ENGINE ASSEMBLY REPLACEMENT

This task covers:

- a. Compressor Testing
- b. Removal
- c. Installation

INITIAL SETUP

Equipment
Condition

<u>Para</u>	<u>Condition Description</u>	<u>Tools</u>
4-8	Engine stopped, power disconnected, fuel line disconnected, muffler and housing removed.	General Mechanic's Tool Kit, item 1, appendix B Common No. 1 Organizational Maintenance Automotive Maintenance and Repair Shop Eqpt, item 2, appendix B
4-24	Spark plugs removed (testing only).	Engine oil, item 10, appendix E Tags, item 22, appendix E Drain pan, appendix D

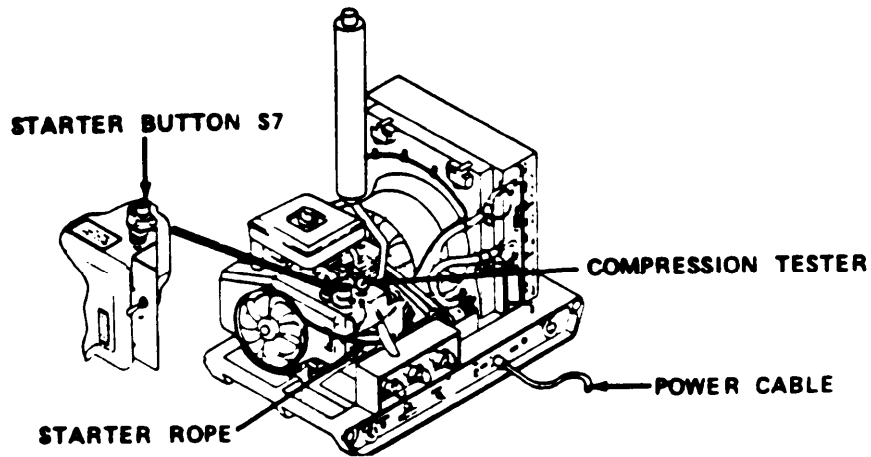

4-19. ENGINE ASSEMBLY REPLACEMENT (CONT)**a. Compressor Testing**

- 1 Insert compression tester in one cylinder.
- 2 If electric power available, insert power cable in 12/24 VOLT INPUT FOR STARTING connection. Push starter button S7. If electric power unavailable, turn engine with starter rope.
- 3 Note compression displayed on tester.
- 4 Insert compression tester in other cylinder. Repeat step 2.
- 5 Note compression displayed on testers. If there is more than a 25 percent difference between the two readings, notify direct support maintenance.
- 6 Install spark plugs (para 4-24).

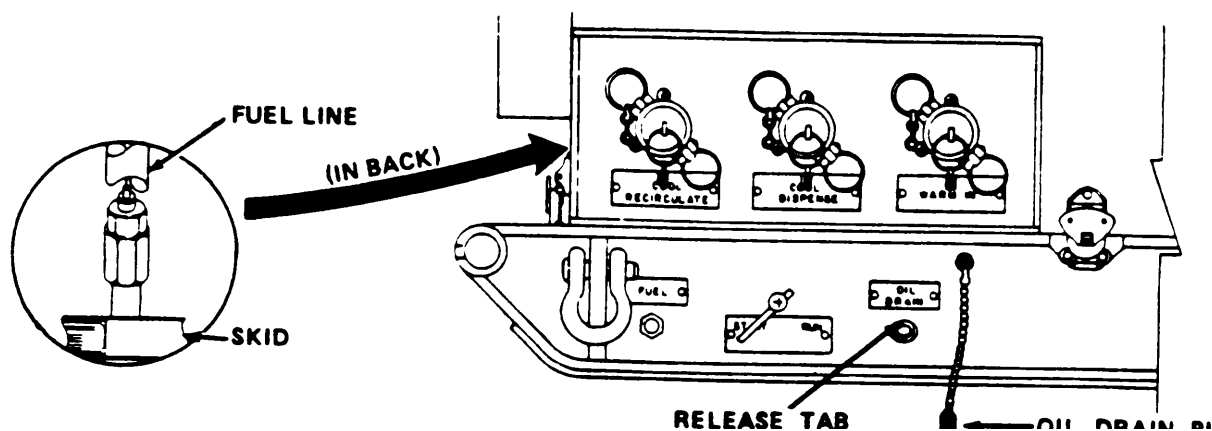
**b. Removal**

- 1 Remove water pump drivebelt (para 4-13).
- 2 Remove compressor drivebelt (para 4-14).
- 3 Disconnect fuel line from engine base connection.
- 4 Place oil drain pan (appendix D) under OIL DRAIN.
- 5 Press release tab and pull out on drain plug. Allow oil to drain. Install plug.

4-19. ENGINE ASSEMBLY REPLACEMENT (CONT)

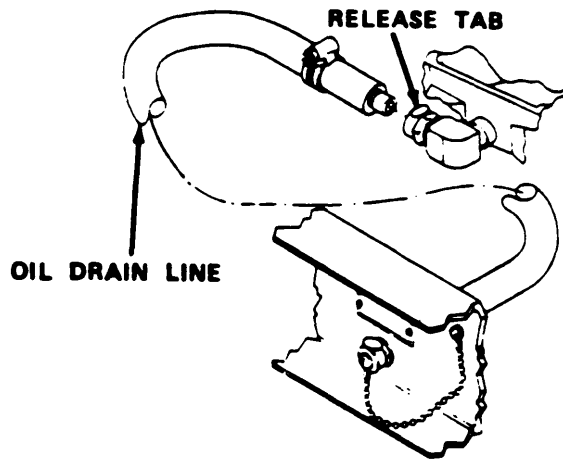

6 Press release tab. Disconnect crankcase oil drain line at base of engine.

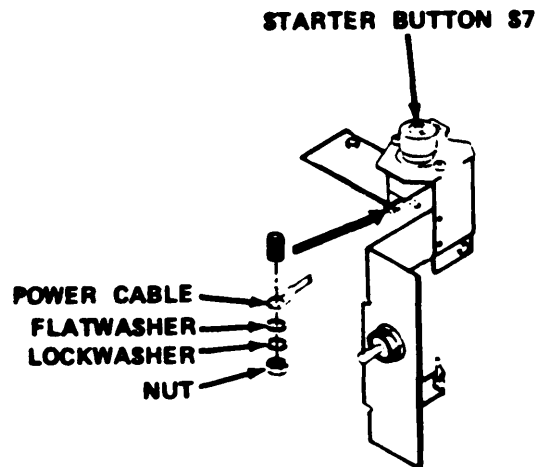

WARNING

To prevent electric shock, make sum power is disconnected from 12/24 VOLT INPUT FOR STARTING connection before performing this procedure.

7 Remove nut, lockwasher, and flatwasher. Remove power cable from starter button S7.

4-19. ENGINE ASSEMBLY REPLACEMENT (CONT)

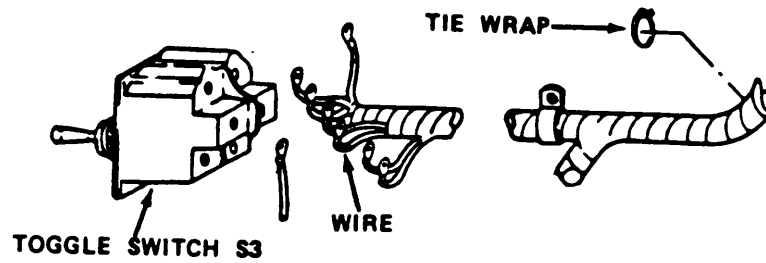

- 8 Cut tie wrap holding wires and remove.
- 9 Tag and remove eight wires on back of toggle switch S3.

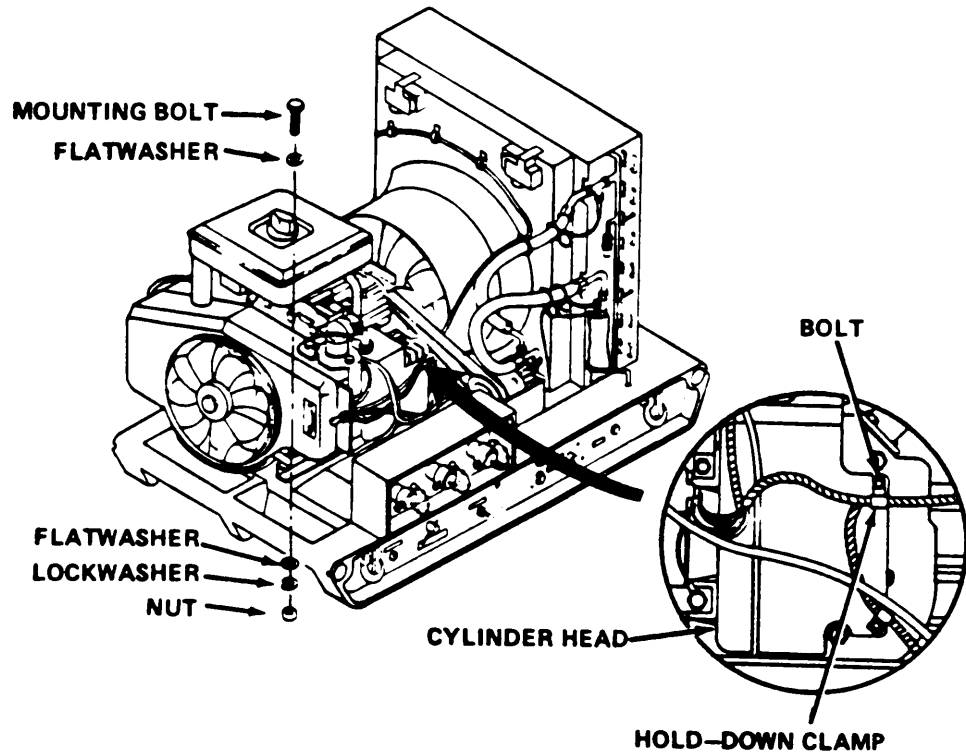

- 10 Remove two bolts and two wire hold-down clamps from cylinder head.
- 11 Remove four engine mounting bolts, four nuts, eight flatwashers, and four lockwashers.

4-19. ENGINE ASSEMBLY REPLACEMENT (CONT)

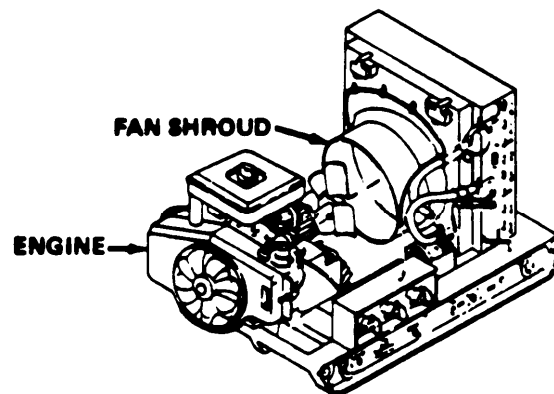

12 Slide engine back free of fan shroud and remove from water chiller base.

13 Remove fan assembly (para 4-15).

14 Remove pulley drive (applicable to water chillers, Model LCW-2685) (para 4-16).

15 Remove centrifugal clutch (applicable to water chillers, Model LCC2685 only) (para 4-17).

c. Installation

1 Install pulley drive (applicable to water chiller, Model LCW-2685) (para 4-16).

2 Install centrifugal clutch (applicable to water chillers, Model LCC2685 only) (para 4-17).

3 Install fan assembly (para 4-15).

4 Place engine on water chiller base and slide forward to align mounting bolt holes.

5 Install four engine mounting bolts, four nuts, eight flatwashers, and four lockwashers.

4-19. ENGINE ASSEMBLY REPLACEMENT (CONT)

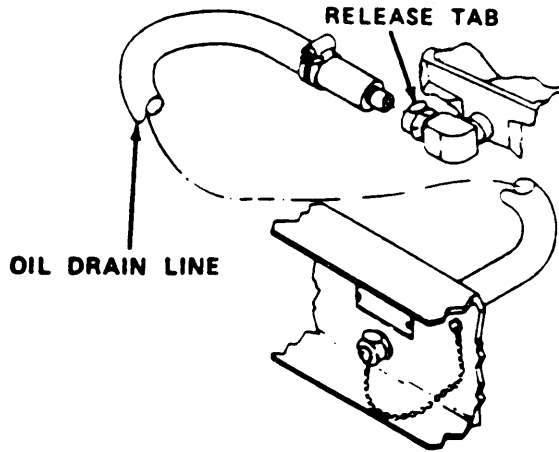

6 Press release tab. Connect engine oil drain line to engine,

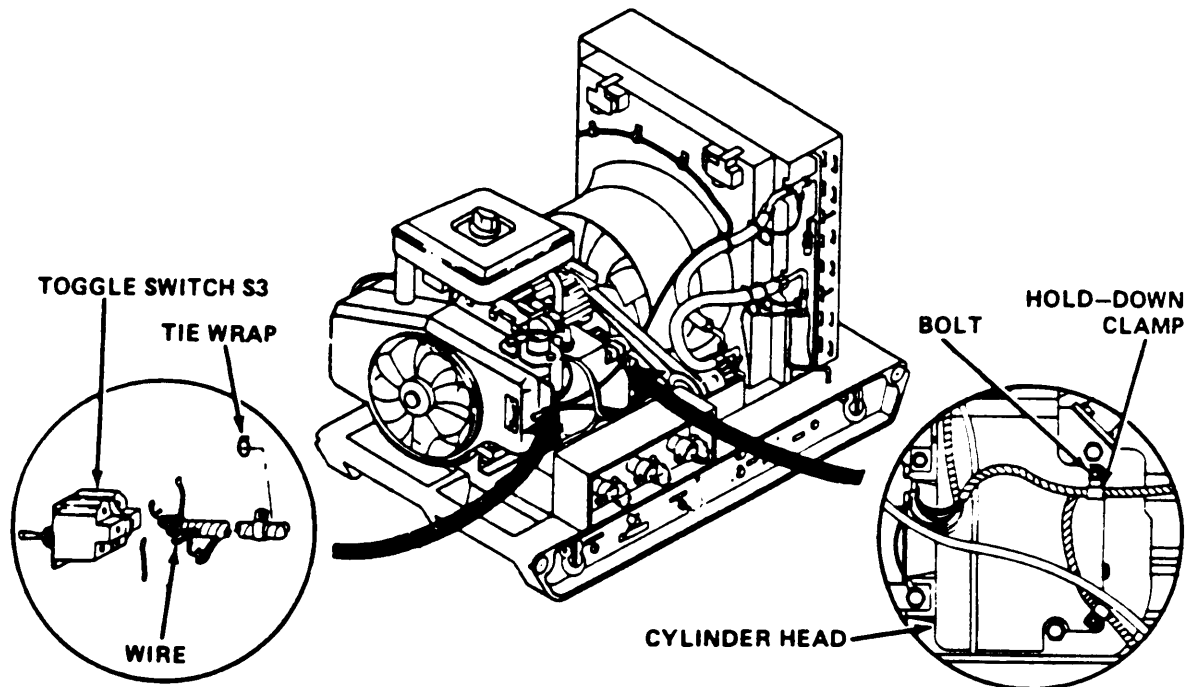

7 Install two bolts and two wire hold-down clamps on cylinder head assembly.

8 Install eight wires on back of toggle switch S3. Remove tags. Install tie wrap.

4-19. ENGINE ASSEMBLY REPLACEMENT (CONT)

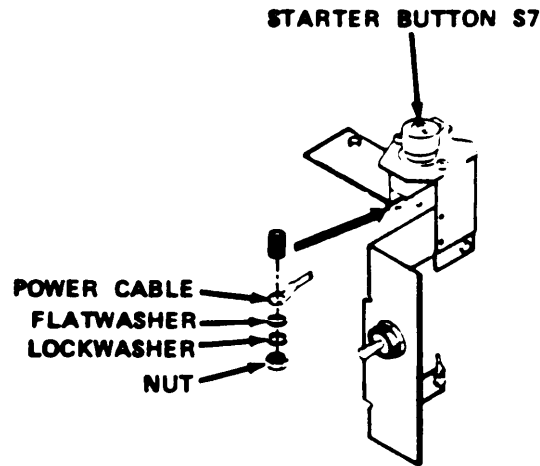

- 9 Install power cable to starter button S7. Install flatwasher, lockwasher, and nut.
- 10 Install fuel line to engine base connection.
- 11 Fill engine with oil.
- 12 Install compressor drivebelt (para 4-14).
- 13 Install water pump drivebelt (para 4-13).

4-20. AIR CLEANER ELEMENTS REPLACEMENT

This task covers:

- a. Removal
- b. Installation

INITIAL SETUP

Equipment
Condition

Materials/Parts

<u>Para</u>	<u>Condition Description</u>	<u>Materials/Parts</u>
4-8	Engine stopped, power disconnected, fuel line disconnected, muffler and housing removed.	Engine oil, item 10, appendix E

4-20. AIR CLEANER ELEMENTS REPLACEMENT (CONT)

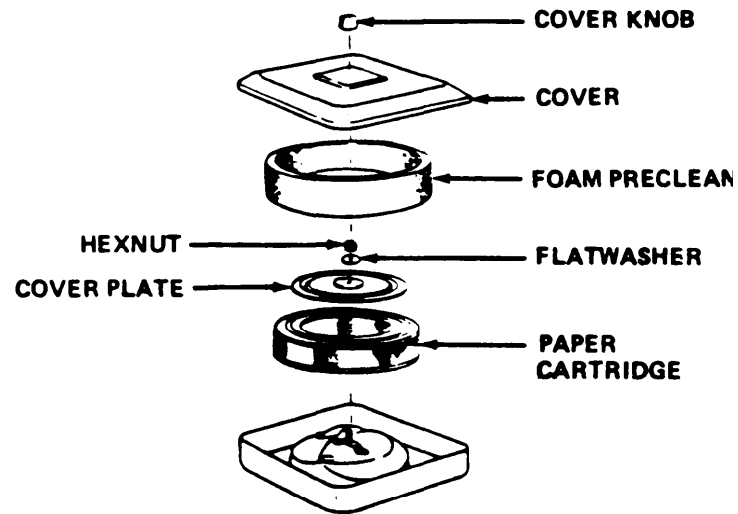

a. Removal

- 1 Remove cover knob. Liftoff cover.
- 2 Remove foam precleaned from around paper cartridge.
- 3 Remove hexnut and flatwasher.
- 4 Lift off cover plate. Remove paper cartridge.

b. Installation

- 1 Install paper cartridge. Install cover plate.
- 2 Install hexnut and flatwasher. Hand-tighten.
- 3 Oil new foam precleaned with 1 oz (30 ml) of engine oil. Squeeze to spread oil.
- 4 Install foam precleaned around paper cartridge.
- 5 Install cover and cover knob.

4-21. CARBURETOR REPLACEMENT

This task covers:

- a. Removal
- b. Installation
- c. Adjustment

INITIAL SETUP

Equipment

Condition

<u>Para</u>	<u>Condition Description</u>	<u>Tools</u>
4-8	Engine stopped, power disconnected, muffler and housing removed.	General Mechanic's Tool Kit, item 1, appendix B
4-20	Air cleaner elements removed.	

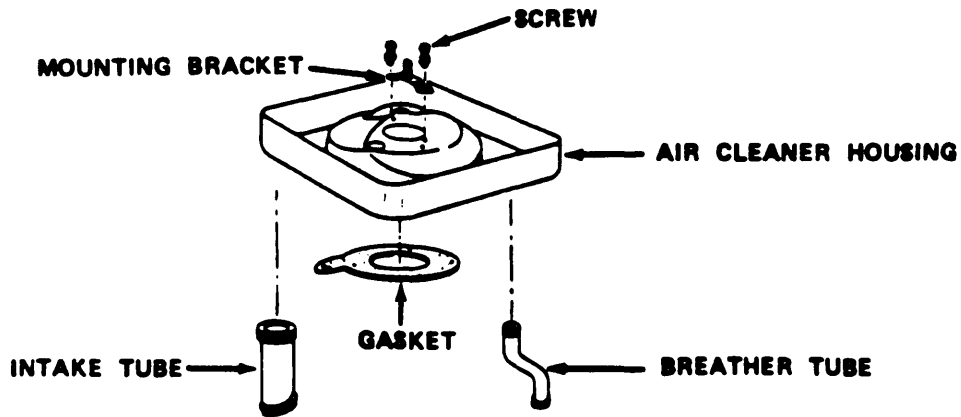

WARNING

Fuel may be present in carburetor. To prevent explosion or fire, keep sparks and open flame away from carburetor.

a. Removal

- 1 Remove intake tube and two breather tubes.
- 2 Remove two screws.
- 3 Remove mounting bracket, air cleaner housing, and gasket.

4-21. CARBURETOR REPLACEMENT (CONT)

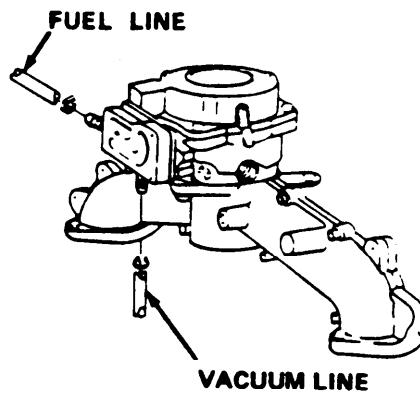

4 Disconnect fuel line and vacuum line.

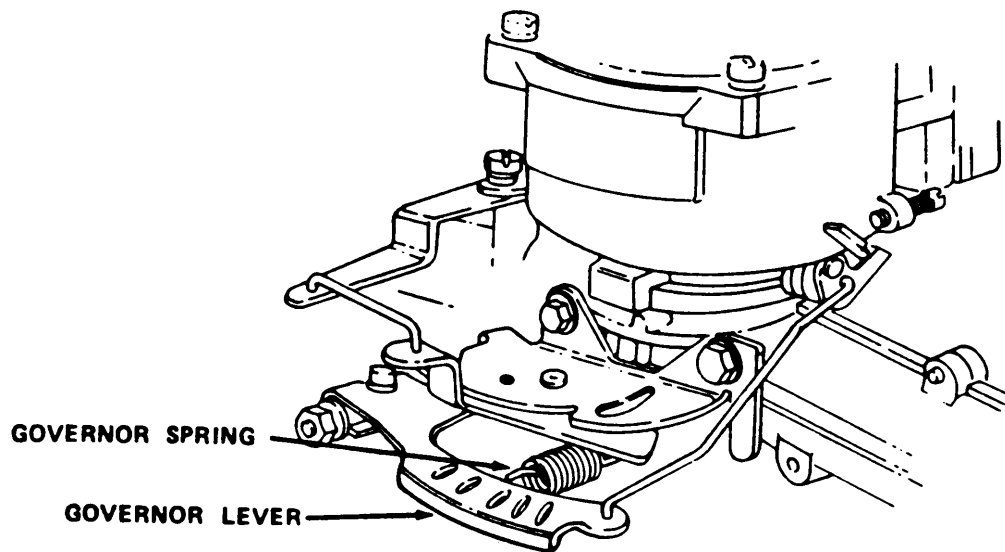

5 Mark hole in governor lever in which governor spring is inserted.

6 Disconnect governor spring from governor lever.

4-21. CARBURETOR REPLACEMENT (CONT)

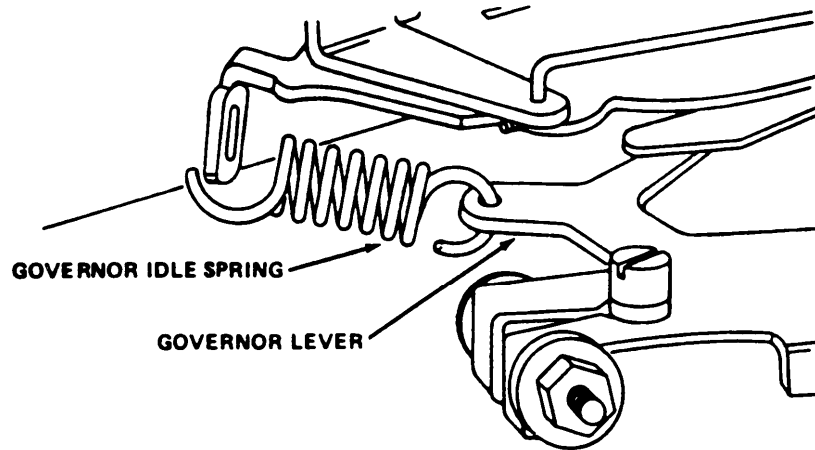

7 Disconnect governor idle spring.

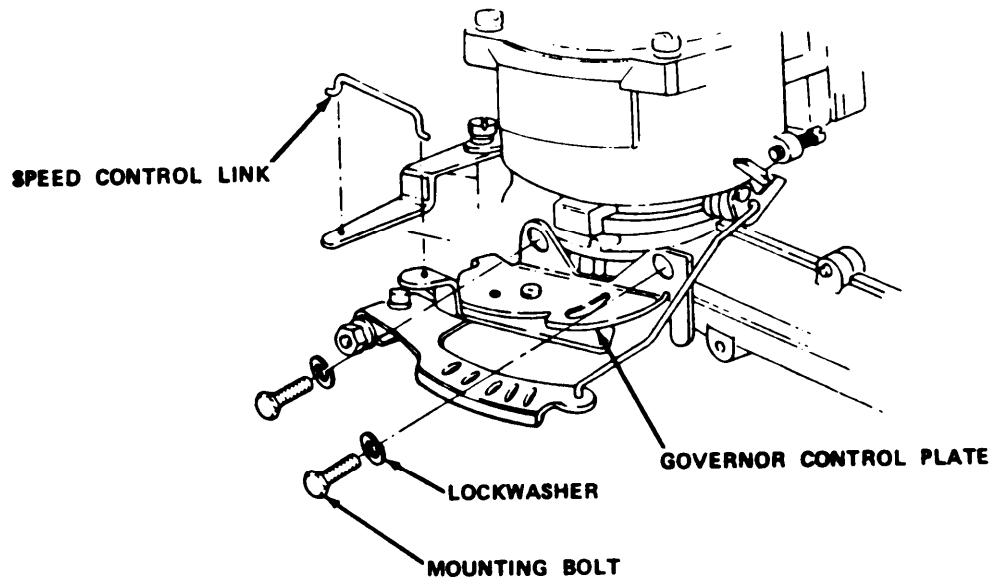

8 Remove two mounting bolts and two lockwashers from governor control plate.

9 Remove governor control plate and speed control link.

4-21. CARBURETOR REPLACEMENT (CONT)

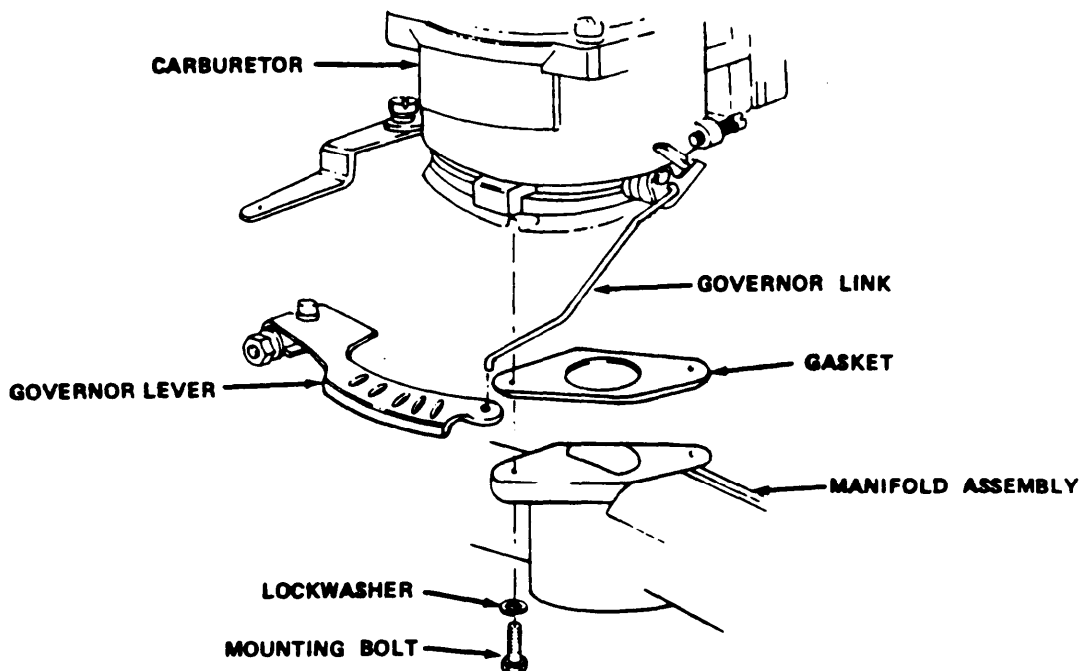

10 Remove two carburetor mounting bolts and two lockwashers from base of manifold.

CAUTION

To prevent damage to governor link, remove carburetor slowly.

11 Remove carburetor and governor link from manifold assembly.

12 Remove gasket and discard.

b. Installation

1 Install gasket on manifold assembly.

2 Place the governor link in the governor lever and install new carburetor on the manifold assembly.

3 Install two carburetor mounting bolts and two lockwashers on base of manifold.

4-21. CARBURETOR REPLACEMENT (CONT)

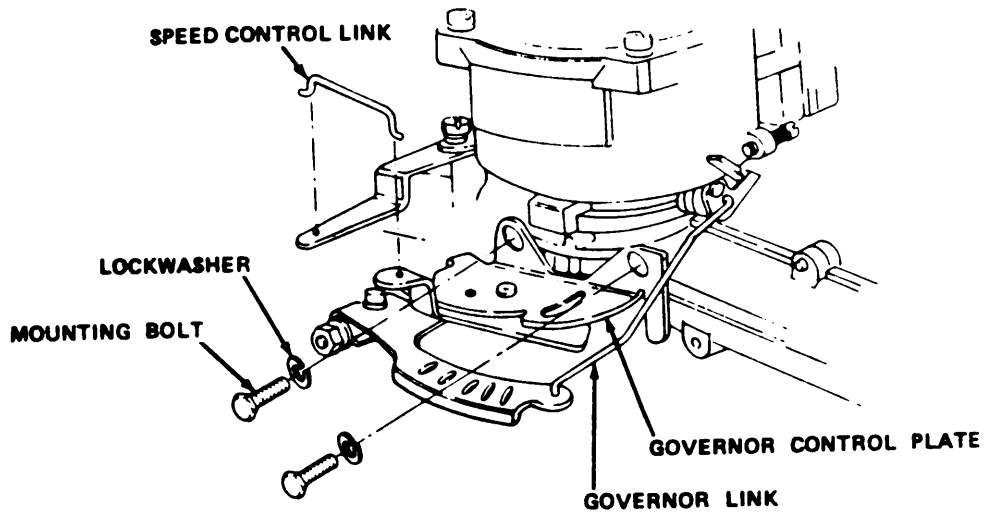

4 Install governor control plate and speed control link.

5 Install two mounting bolts and two lockwashers in governor control plate.

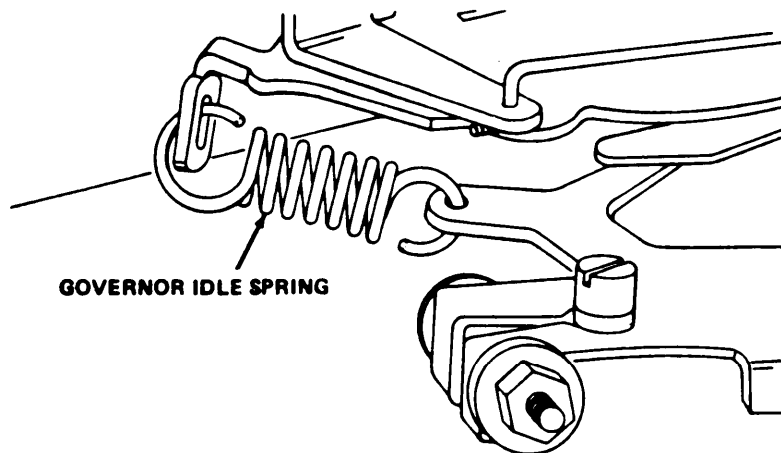

6 Connect governor idle spring.

4-21. CARBURETOR REPLACEMENT (CONT)

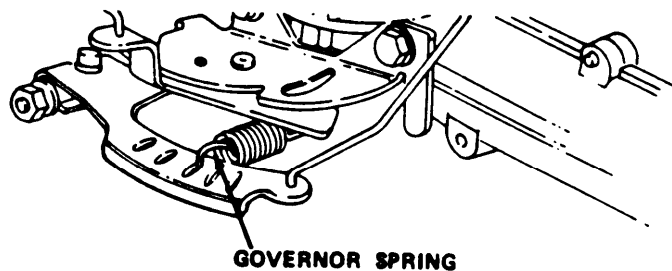

7 Connect governor spring in same hole from which it was removed.

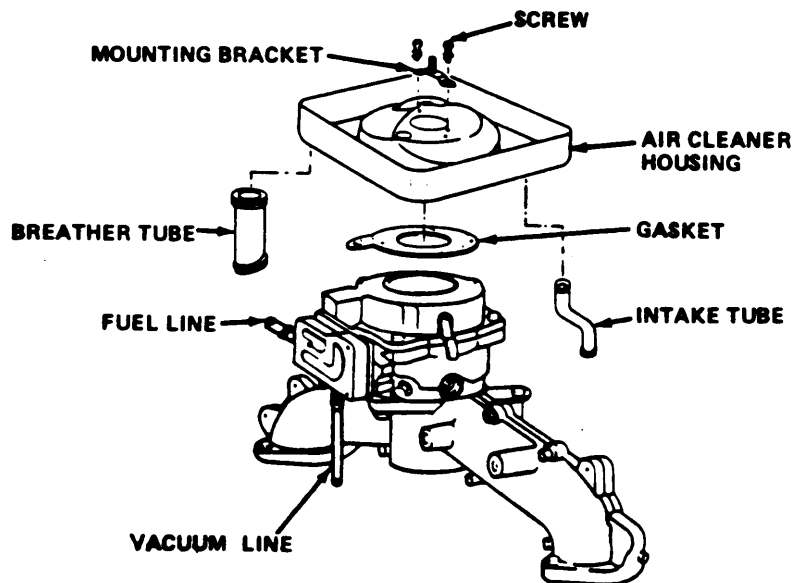

8 Connect fuel line and vacuum line.

9 Install gasket, air cleaner housing, and mounting bracket.

10 Install two screws.

11 Install intake tube and two breather tubes.

12 Install air cleaner elements (para 4-20).

4-21. CARBURETOR REPLACEMENT (CONT)

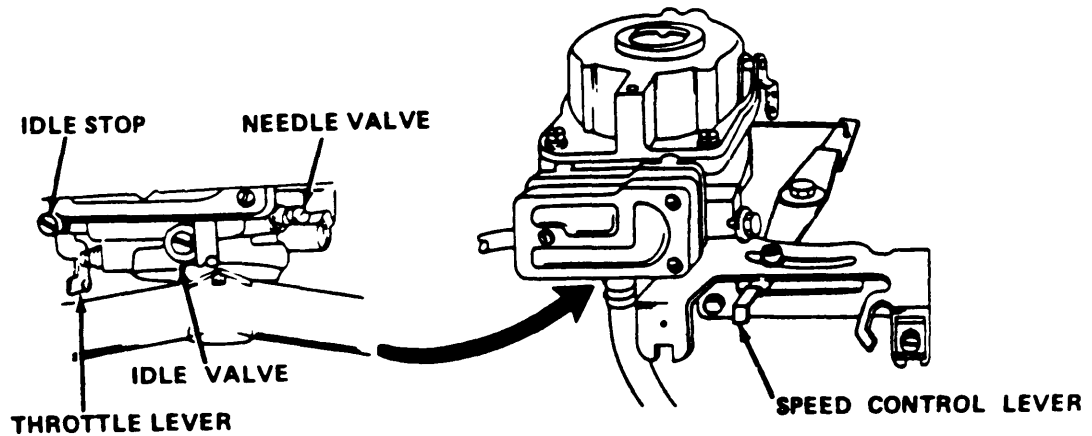

CAUTION

To prevent damage to valves, DO NOT turn them too far.

NOTE

Steps 1 and 8 apply only to those carburetors equipped with a needle valve.

- 1 Turn needle valve until it just closes. Turn needle valve 1-1/2 turns to left.
- 2 Turn idle valve until it just closes. Turn idle valve 1-1/2 turns to left.
- 3 Start and warm up engine (para 2-6a).
- 4 Place speed control lever in idle position.
- 5 Hold throttle lever against idle stop.
- 6 Turn idle valve slowly to right until engine misses or speed drops. Turn idle valve 1/2 turn to left.
- 7 Place speed control lever in fast position.
- 8 Turn needle valve slowly to right until engine misses or speed drops. Turn needle valve 1/2 turn to left.

4-22. INTAKE MANIFOLD ASSEMBLY REPLACEMENT

This task covers:

- a. Removal
- b. Installation

INITIAL SETUP

Equipment

Condition

<u>Para</u>	<u>Condition Description</u>	<u>Tools</u>
4-8	Engine stopped, power disconnected, fuel line disconnected, muffler and housing removed.	General Mechanic's Tool Kit, item 1, appendix B
4-20	Air cleaner elements removed.	
4-21	Carburetor removed.	

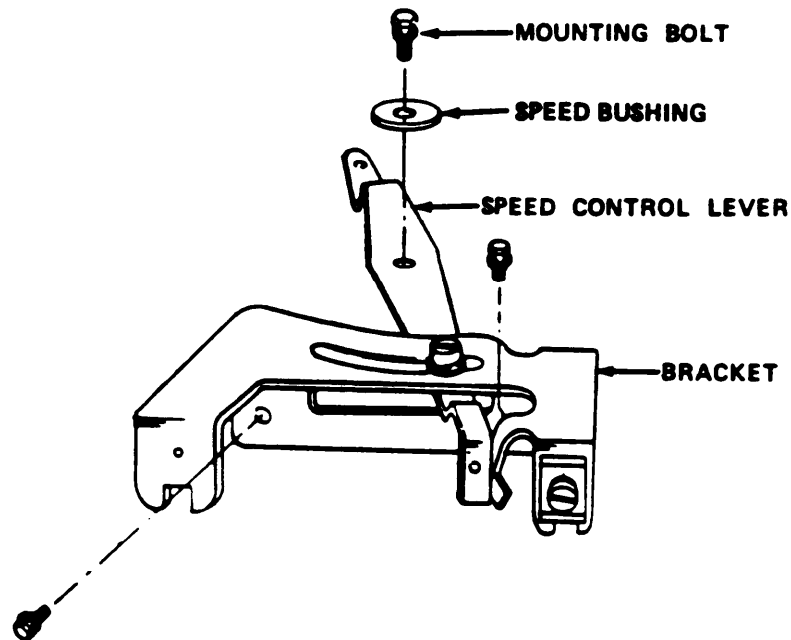

- 1 Remove three speed control lever mounting bolts and speed bushing. Remove speed control lever and bracket.

4-22. INTAKE MANIFOLD ASSEMBLY REPLACEMENT (CONT)

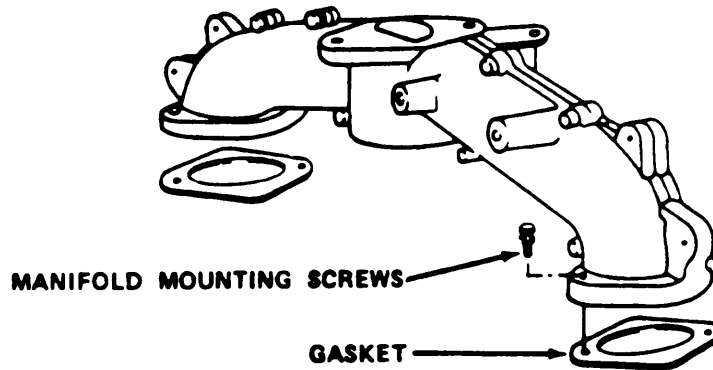

- 2 Remove four manifold mounting screws.
- 3 Remove manifold and two gaskets. Discard gaskets.

b. Installation

- 1 Install manifold gaskets on manifold openings.
- 2 Install manifold over gaskets.
- 3 Install four manifold mounting screws.

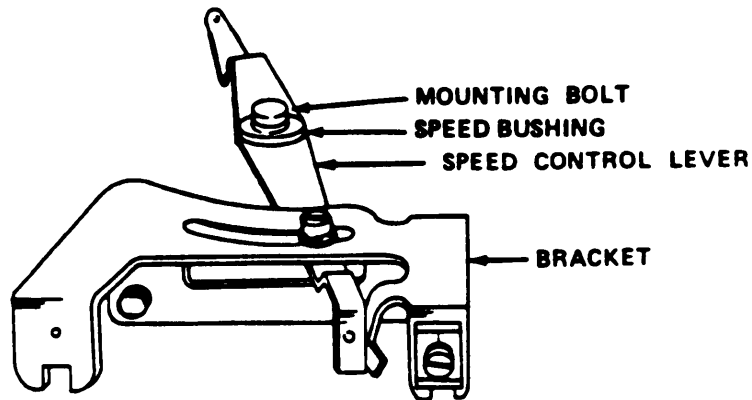

- 4 Install speed control lever and bracket. Install speed bushing and three speed control lever mounting bolts.
- 5 Install carburetor (para 4-21).
- 6 Install air cleaner elements (para 4-20).

4-23. STARTER PANEL ASSEMBLY REPLACEMENT/REPAIR

This task covers:

- a. Testing
- b. Removal
- c. Installation

INITIAL SETUP

Condition

<u>Para</u>	<u>Condition Description</u>	<u>Tools</u>
4-8	Engine stopped, power disconnected, fuel line disconnected, muffler and housing removed.	Common No. 1 Organizational Maintenance Automotive Maintenance and Repair shop Eqpt, item 2, appendix B
4-34	Vehicle receptacle assembly tested.	

Materials/Parts

Tags, item 22, appendix E

NOTE

Repair of the starter panel assembly consists of replacement of starter button S7 or mounting bracket or replacement of cable.

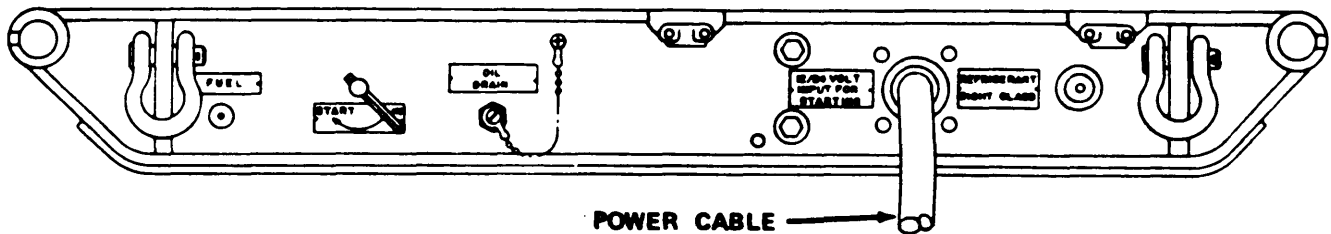

a. Testing

- 1 Connect power cable to 12/24 VOLT INPUT FOR STARTING connection.
- 2 Set multimeter for voltage test.

4-23. STARTER PANEL ASSEMBLY REPLACEMENT/REPAIR (CONT)

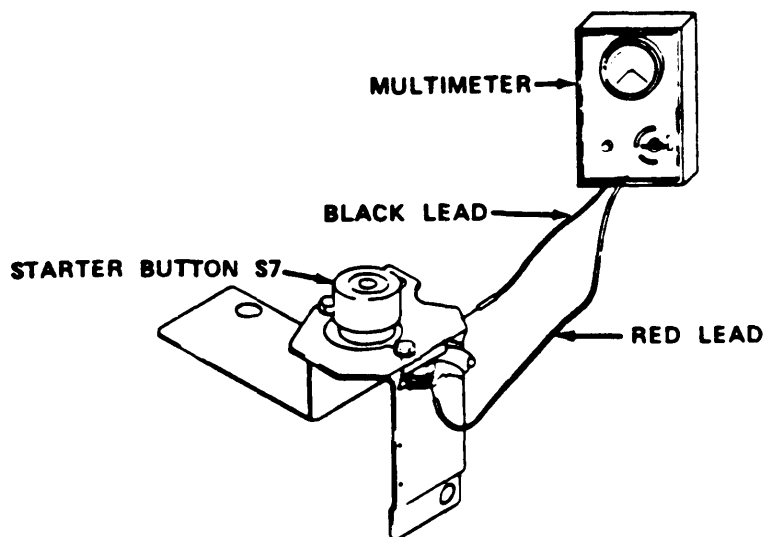

- 3 Place black lead on good ground (metal engine part). Place red lead on terminal of starter button S7 leading to vehicle receptacle assembly. Note voltage. If voltage not present, replace cable.
- 4 Place red lead on terminal of starter button S7 leading to starter.
- 5 Press starter button S7 and note voltage.
- 6 If voltage from second reading is the same as the first, switch is good. If voltage from second reading is less than first, replace switch.

4-23. STARTER PANEL ASSEMBLY REPLACEMENT/REPAIR (CONT)

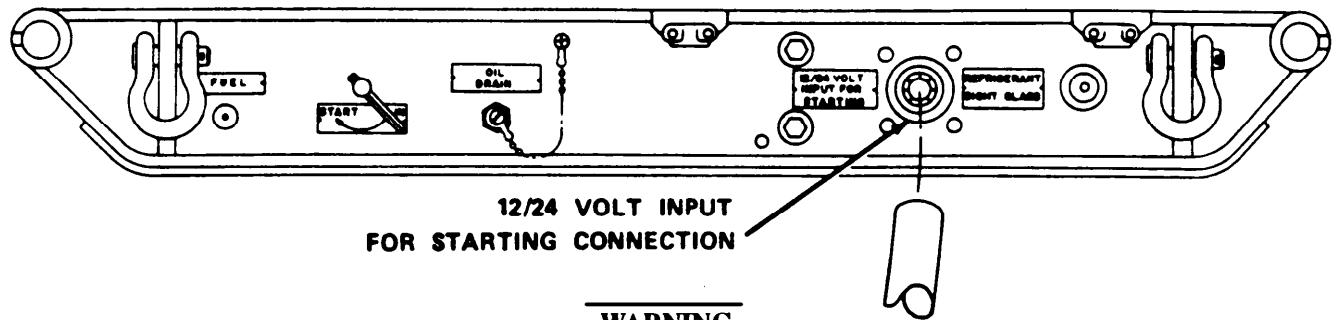

WARNING

To prevent electric shock, make sure power is disconnected from 12/24 VOLT INPUT FOR STARTING connection before performing this procedure.

b. Removal

- 1 Disconnect power cable from 12/24 VOLT INPUT FOR STARTING connection.

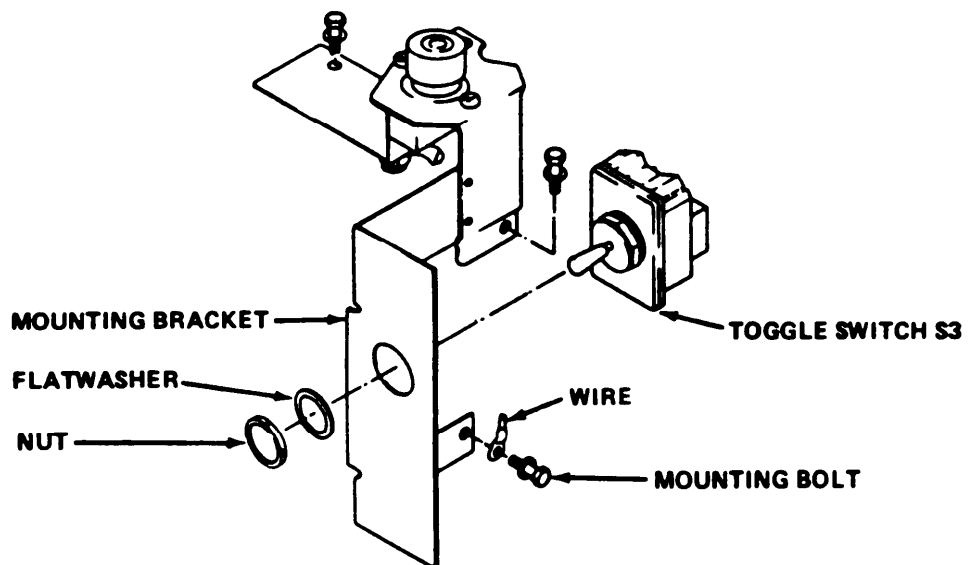

- 2 Remove mounting nut and flatwasher. Remove toggle switch S3 from mounting bracket.
- 3 Remove three mounting bracket bolts. Remove mounting bracket. Remove toggle switch S3 wire and flatwasher from bolt.

4-23. STARTER PANEL ASSEMBLY REPLACEMENT/REPAIR (CONT)

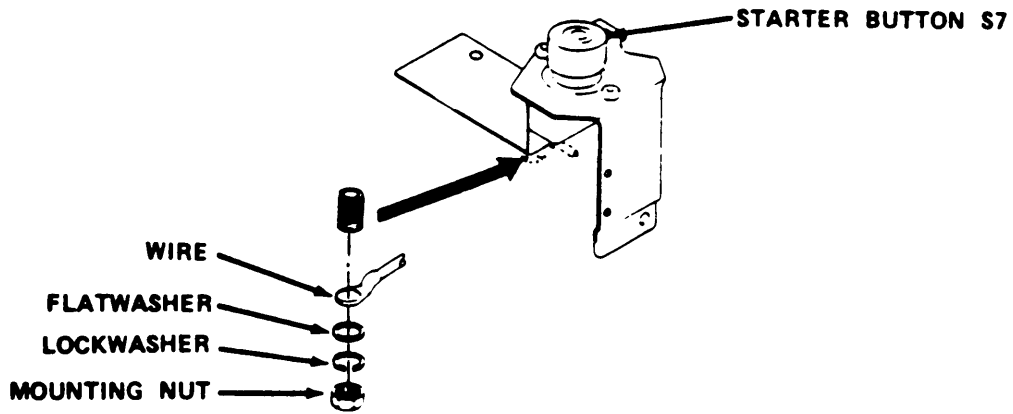

- 4 Tag two wires under starter button S7.
- 5 Remove two wire mounting nuts, two lockwashers, and two flatwashers. Remove two wires.

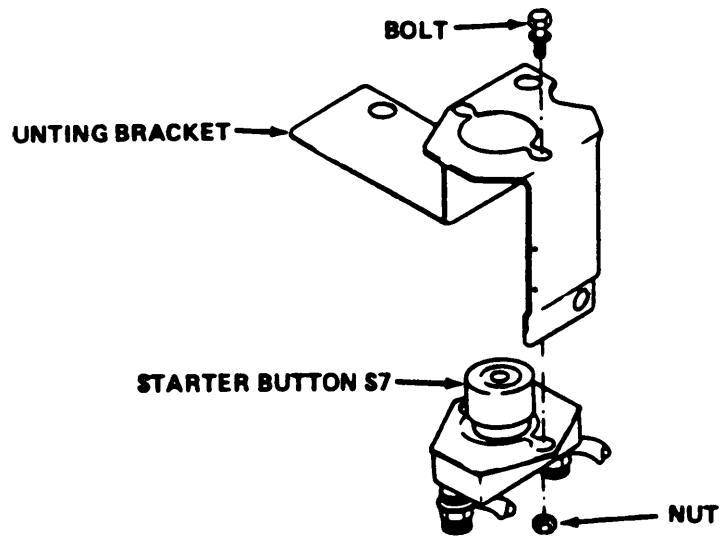

- 6 Remove two mounting bolts and two nuts.
- 7 Remove starter button S7.

4-23. STARTER PANEL ASSEMBLY REPLACEMENT/REPAIR (CONT)

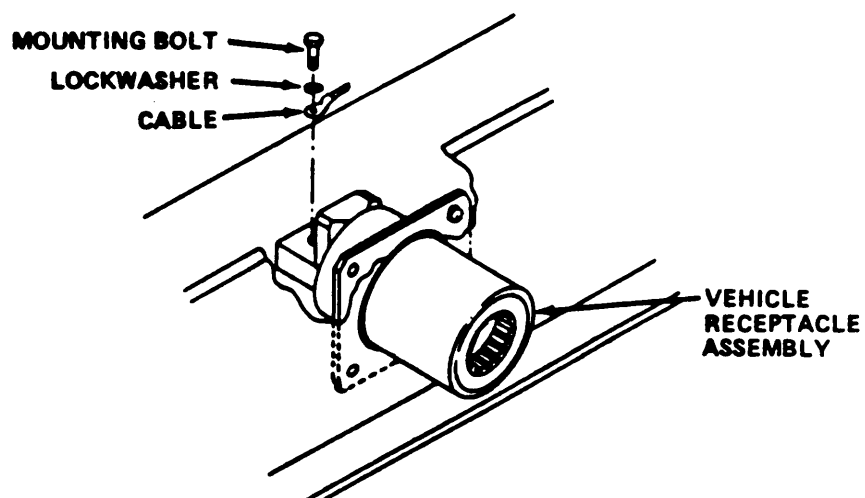

8 Remove cable mounting bolt and lockwasher from vehicle receptacle assembly.

9 Cut tie wrap and remove cable.

c. Installation

1 Route cable beneath compressor and install on vehicle receptacle assembly. Install cable mounting bolt and lockwasher.

2 Install tie wrap around cable and wiring harness.

4-23. STARTER PANEL ASSEMBLY REPLACEMENT/REPAIR (CONT)

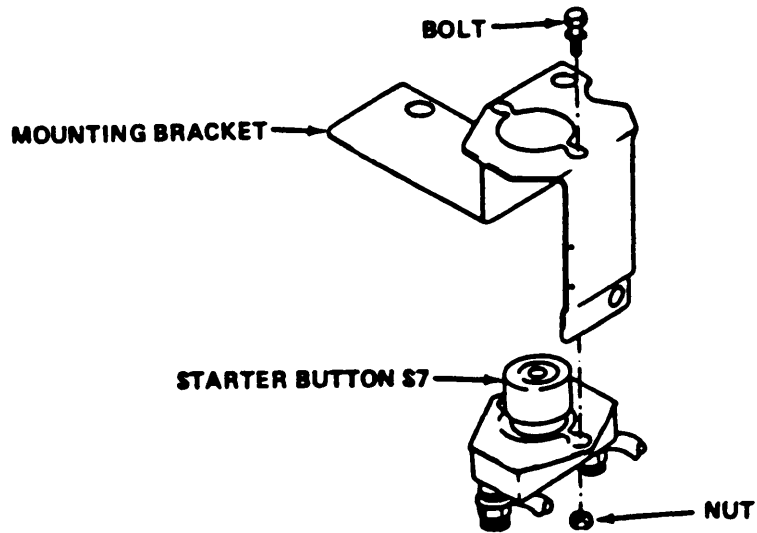

3 Install starter button S7 in mounting bracket. Install two bolts and two nuts.

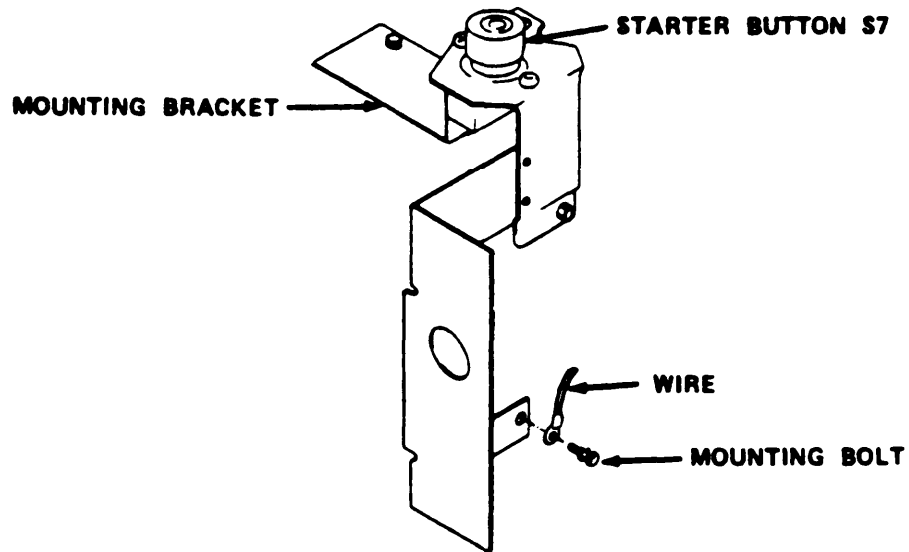

4 Install mounting bracket on engine. Install toggle switch S3 wire on mounting bolt. Install three mounting bolts.

4-23. STARTER PANEL ASSEMBLY REPLACEMENT/REPAIR (CONT)

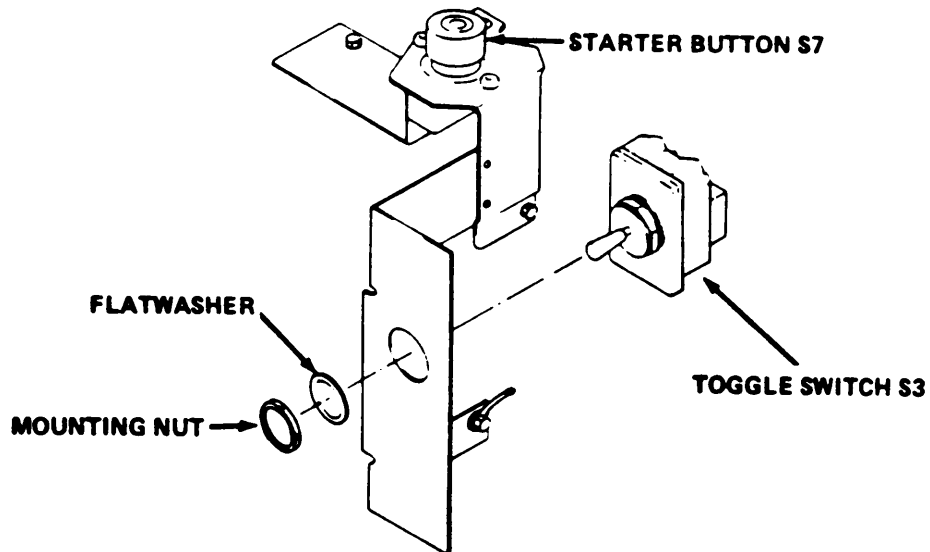

5 Install toggle switch S3 in mounting bracket. Install flatwasher and mounting nut.

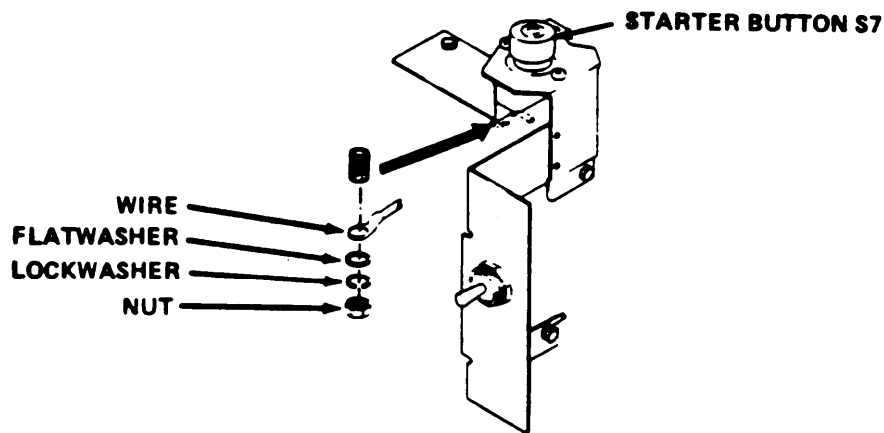

6 Install starter button S7 wires. Install two flatwashers, two lockwasher, and two nuts. Remove tags.

4-24. SPARK PLUGS REPLACEMENT

This task covers:

- a. Removal
- b. Adjustment
- c. Installation

INITIAL SETUP

Equipment

Condition

Para

Condition Description

Tools

4-8

Engine stopped, power disconnected, fuel line disconnected, muffler and housing removed.

General Mechanic's Tool Kit, item 1, appendix B

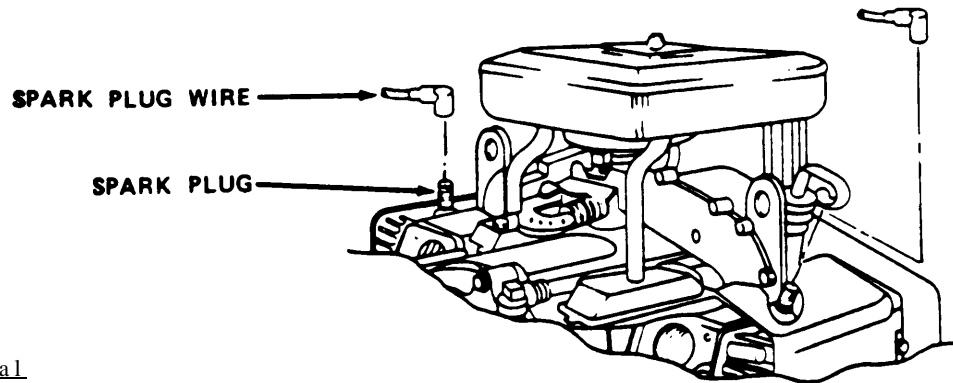

a. Removal

- 1 Remove two spark plug wires from spark plugs.
- 2 Remove two spark plugs.

b. Adjustment

- 1 Gap each spark plug to 0.30 in. (7.6 mm).

c. Installation

- 1 Install two spark plugs and hand-tighten until snug.
- 2 Torque two spark plugs to 200 in. lb (22.8 Nm).
- 3 Attach two sparkplug wires to spark plugs.

4-25. ARMATURE GROUP REPLACEMENT/REPAIR

This task covers:

- a. Inspection
- b. Testing
- c. Adjustment
- a. Disassembly
- e. Assembly

INITIAL SETUP

Equipment

Condition

<u>Para</u>	<u>Condition Description</u>
4-8	Engine stopped, power disconnect fuel line disconnected, muffler and housing removed.

<u>Tools</u>
General Mechanic's Tool Kit, item 1, appendix B

Materials/Parts

- Sealant, item 1, appendix E
- Solder, item 20, appendix E
- Tape, item 23, appendix E

Common No. 1 Organizational Maintenance Automotive Maintenance and Repair Shop Eqpt, item 2, appendix B

Personnel Required

Two for testing.

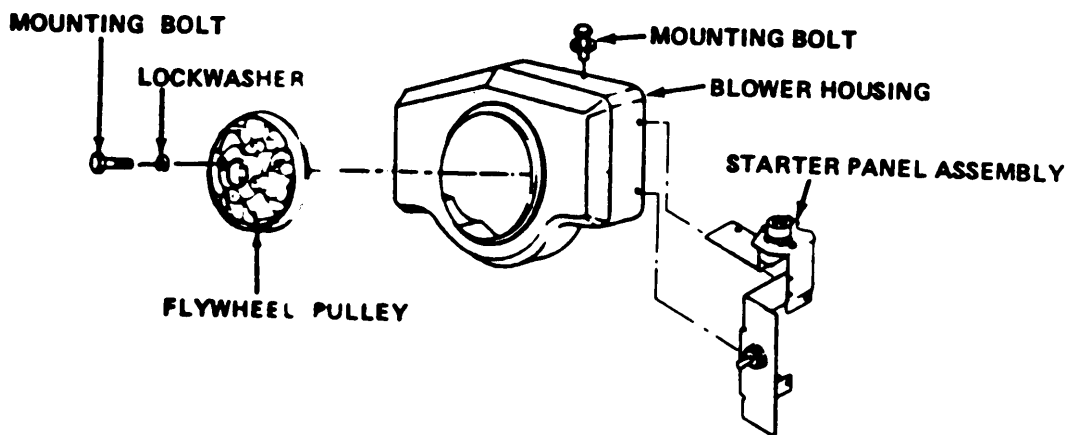

4-25. ARMATURE GROUP REPLACEMENT/REPAIR (CONT)

a. Inspection

- 1 Remove two flywheel pulley mounting bolts and two lockwashers. Remove flywheel pulley.
- 2 Remove eight blower housing mounting bolts. Remove blower housing.
- 3 Move starter panel assembly aside.

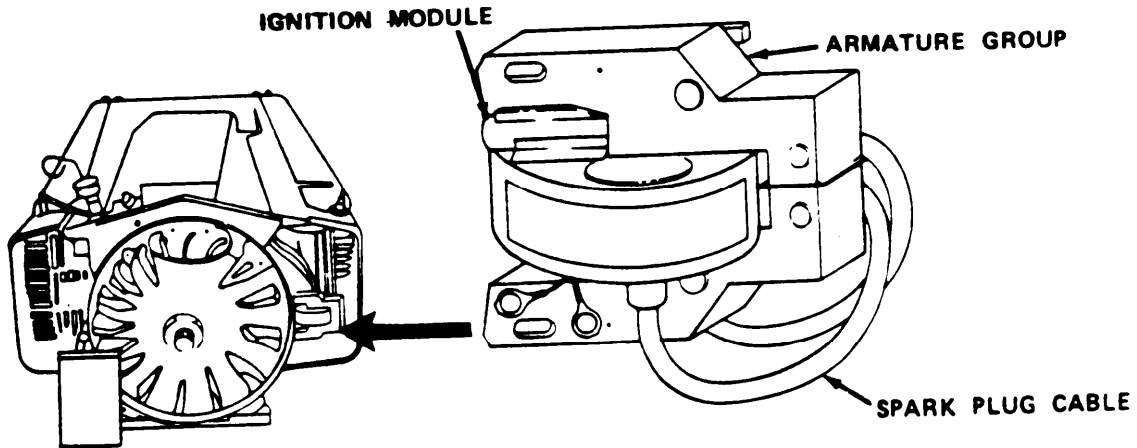

- 4 Check armature group for dirt, oil, and rust. Clean as needed.
- 5 Check for loose wire connections on ignition module. If wire connection loose, replace armature group.
- 6 Check condition of spark plug cables. If cables damaged, replace armature group.

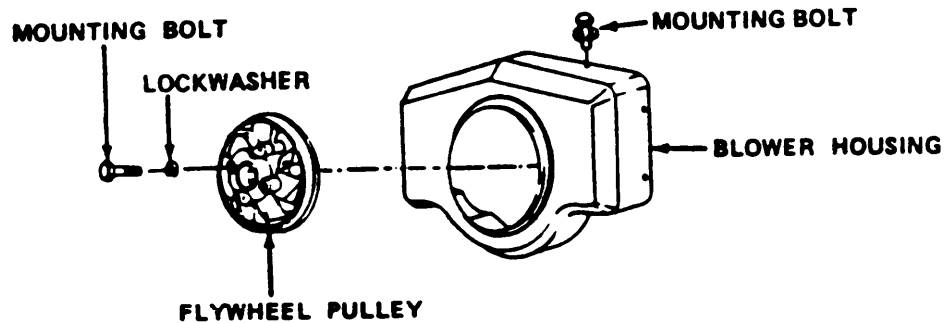

- 7 Install blower housing. Install eight blower housing mounting bolts and starter cable clamp.

4-25. **ARMATURE GROUP REPLACEMENT/REPAIR (CONT)**

8 Install flywheel pulley. Install two lockwashers and two flywheel pulley mounting bolts.

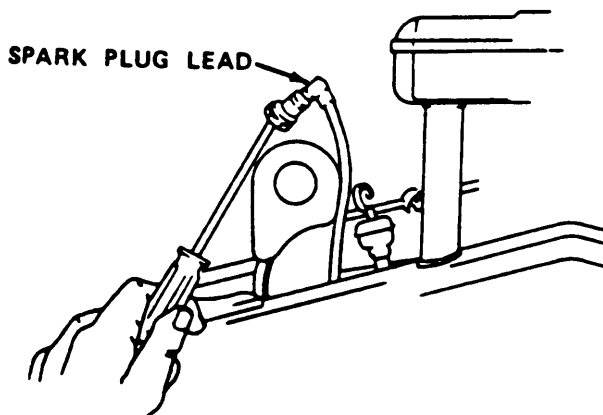

b. Testing

1 Remove spark plugs (para 4-24).

2 Insert end of screwdriver into right cylinder spark plug lead. Hold section of screwdriver shaft about 1/8 in. (1/3 cm) from ground (metal engine part).

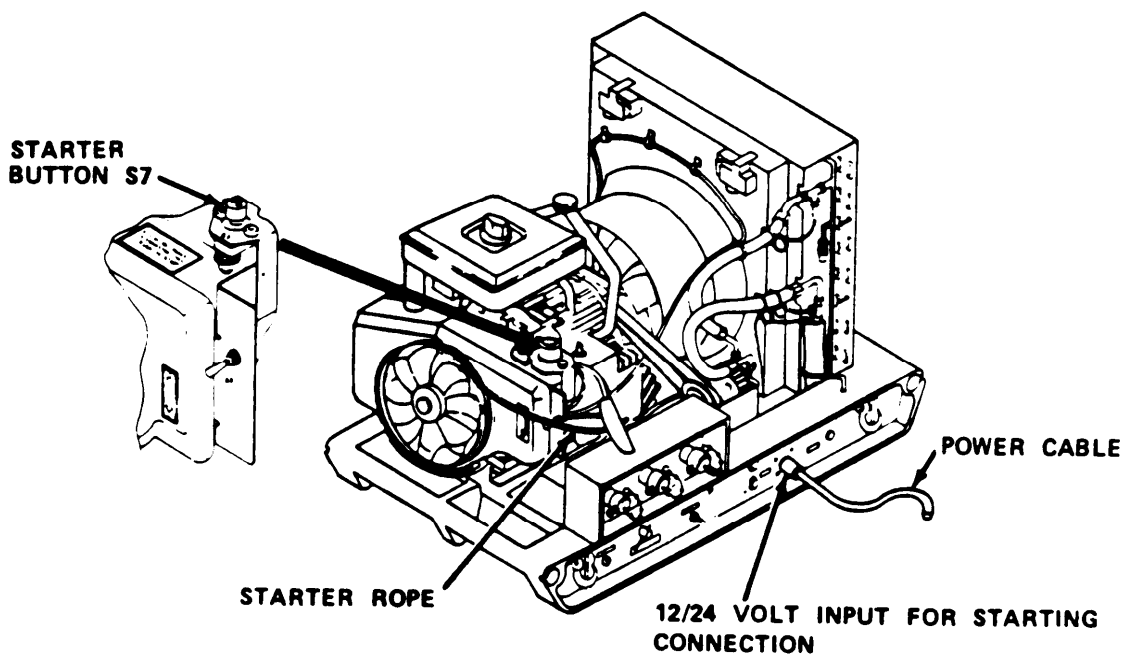

4-25. ARMATURE GROUP REPLACEMENT/REPAIR (CONT)

WARNING

To prevent electric shock, be very careful when connecting power cable to 12/24 VOLT INPUT FOR STARTING connection.

- 3 If electric power available: Insert power cable in 12/24 VOLT INPUT FOR STARTING connection. Hold toggle switch S3 in START position and press down starter button S7.

NOTE

Two persons may be required for next step.

- 4 If electric power unavailable: Hold toggle switch S3 in START position and pull starter rope.
- 5 If spark jumps 1/8-in. (1/3-cm) gap to ground, system is working.
- 6 If spark fails to jump 1/8-in. (1/3-cm) gap to ground, replace/repair armature group.
- 7 Repeat steps 1 through 6 for left cylinder.
- 8 Install spark plugs (para 4-24).

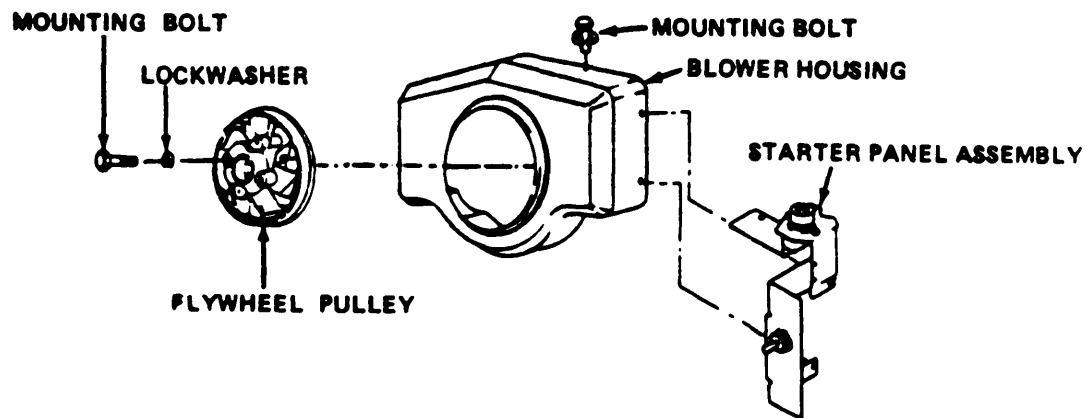

c. Adjustmen

- 1 Remove two flywheel pulley mounting bolts and two lockwashers. Remove flywheel pulley.

4-25. **ARMATURE GROUP REPLACEMENT/REPAIR (CONT)**

- 2 Remove eight blower housing mounting bolts. Remove blower housing.
- 3 Move starter panel assembly aside.

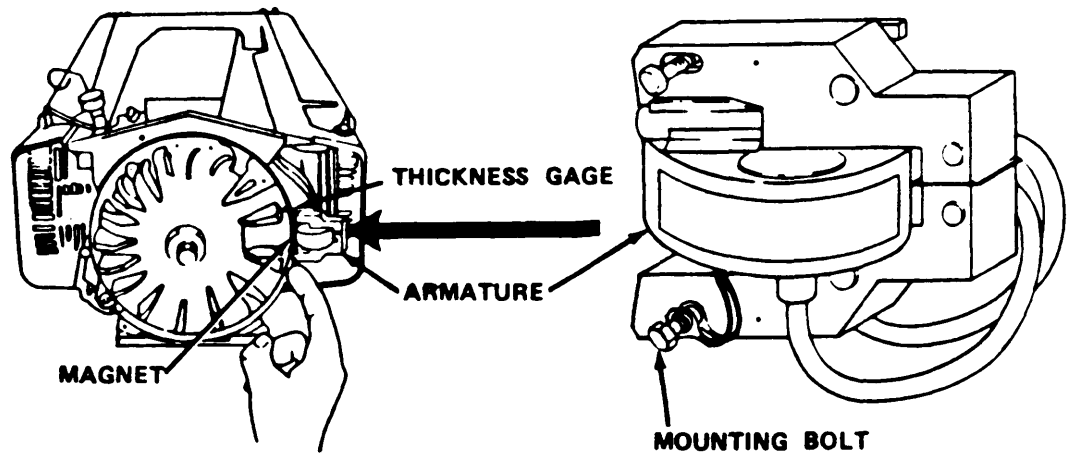

- 4 Insert 0.010 in. (0.254 mm) thickness gage between armature and flywheel with magnet directly in front of armature.
- 5 Loosen two armature mounting bolts. Allow magnet to pull armature down firmly against thickness gage.
- 6 Tighten two armature mounting bolts.
- 7 Remove thickness gage.
- 8 Install blower housing. Install eight blower housing mounting bolts and starter clamp.
- 9 Install flywheel pulley. Install two flywheel pulley mounting bolts and two lockwashers.

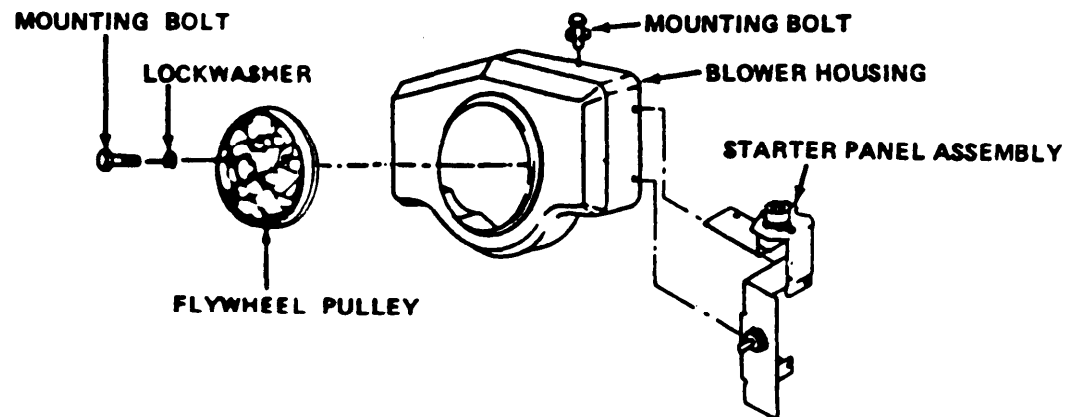

4-25. ARMATURE GROUP REPLACEMENT/REPAIR (CONT)

d. Disassembly

NOTE

Repair of the armature group consists of replacement of defective parts. During disassembly of the armature group, inspect parts for wear and damage. Replace worn or damaged parts.

- 1 Remove carburetor (para 4-21).
- 2 Remove intake manifold (para 4-22).
- 3 Remove two flywheel pulley mounting bolts and two lockwashers. Remove flywheel pulley.
- 4 Remove eight blower housing mounting bolts. Remove blower housing. Move starter panel assembly aside.

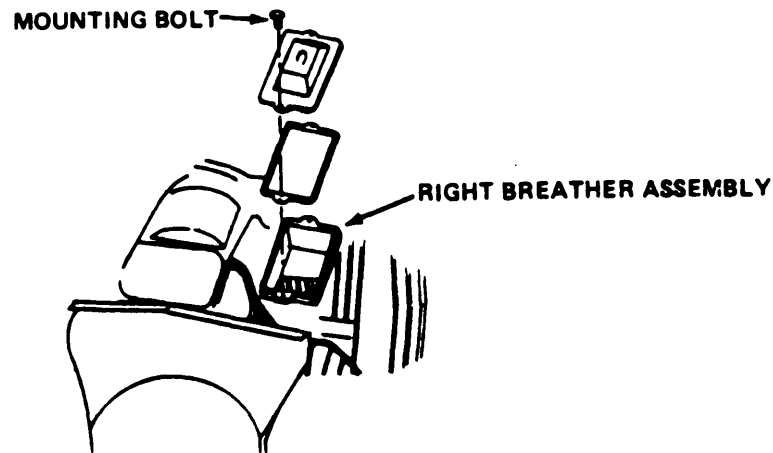

- 5 Disconnect spark plug cables from spark plugs.
- 6 Remove right breather assembly mounting bolts and stop switch wires from breather assembly. Remove breather assembly.

4-25. ARMATURE GROUP REPLACEMENT/REPAIR (CONT)

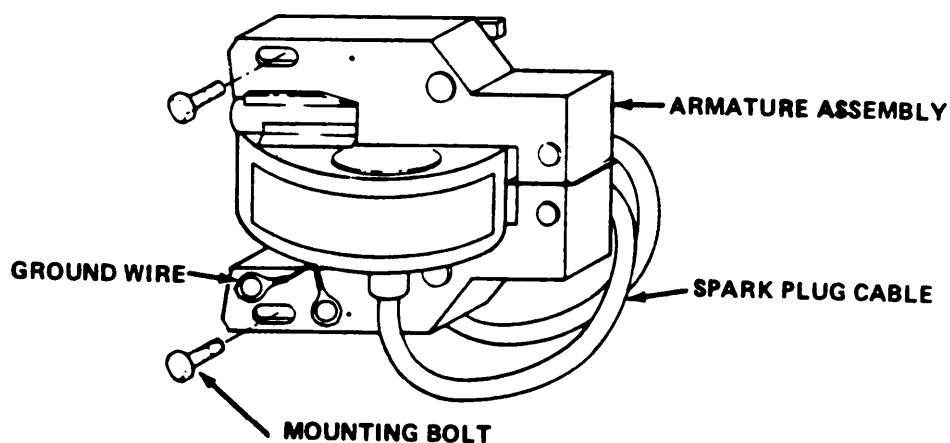

7 Remove two armature mounting bolts and ground wires.

8 Remove armature assembly and sparkplug cables from engine.

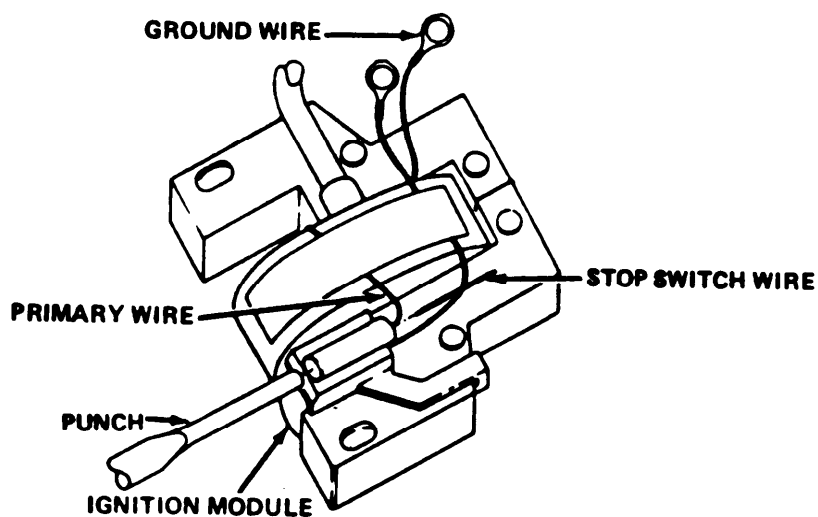

9 Using punch, release stop switch wire from ignition module.

10 Desolder and remove armature primary wire from ground wire and ignition module.

4-25. ARMATURE GROUP REPLACEMENT/REPAIR (CONT)

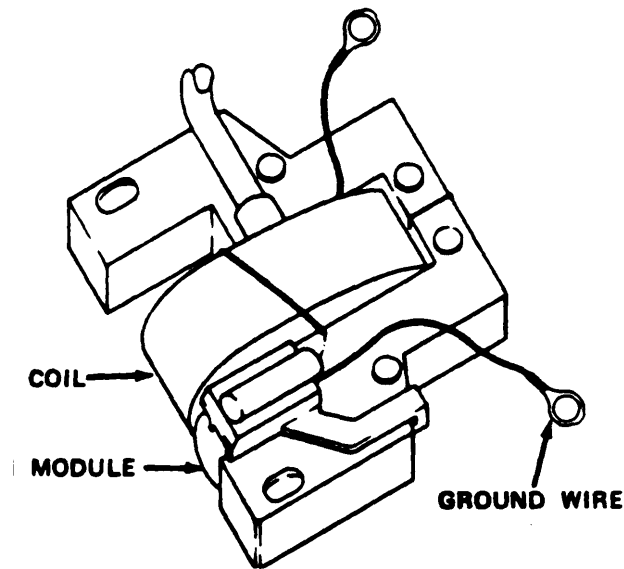

11 Remove tape and sealant. Move ground wires to clear armature coil and laminations.

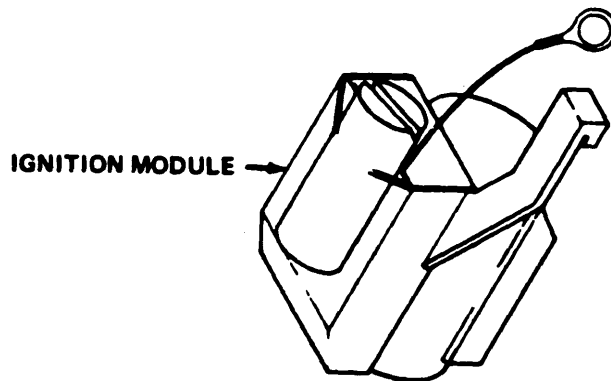

12 Push module and retainer away from laminations. Remove from armature assembly.

e. Assembly

1 Install ignition module in armature assembly.

2 Using sealant to hold them in place, install two ground wires.

4-25. ARMATURE GROUP REPLACEMENT/REPAIR (CONT)

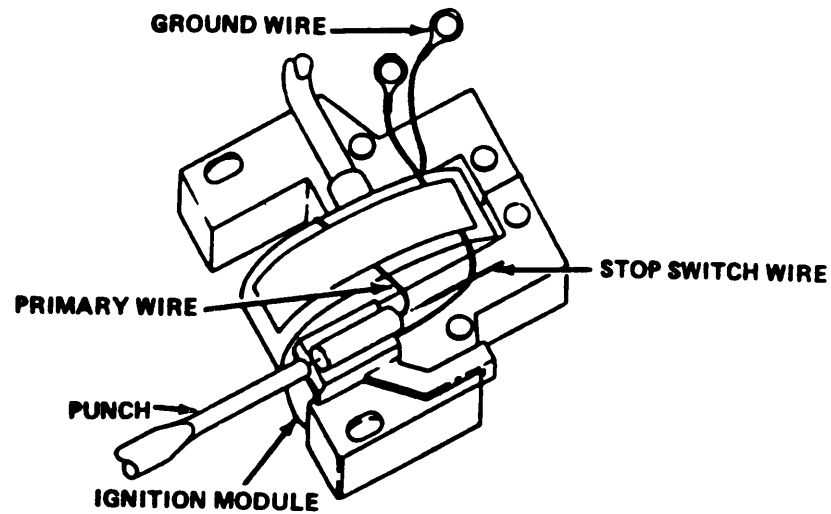

- 3 Install armature primary wire and ground wire to ignition module.
- 4 Solder armature primary wire to ground wire.
- 5 Using punch, install armature stop switch wire to ignition module.

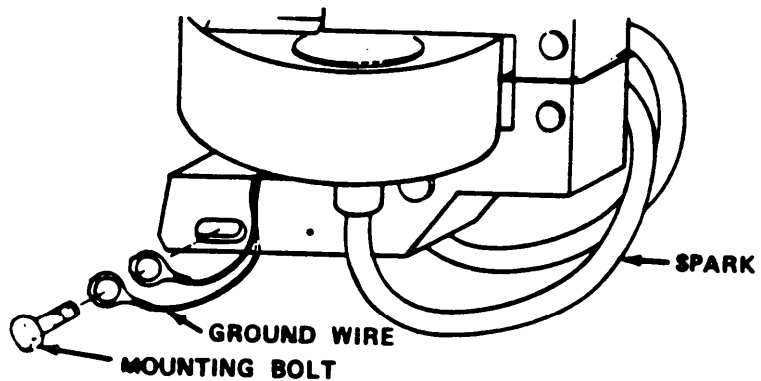

- 6 Install armature assembly and sparkplug cables on engine.
- 7 Place ground wires on lower mounting bolt. Install two armature mounting bolts.
- 8 Tape down primary wire and ground wire.

4-25. ARMATURE GROUP REPLACEMENT/REPAIR (CONT)

9 Adjust armature assembly.

10 Install right breather assembly and stop switch wires.

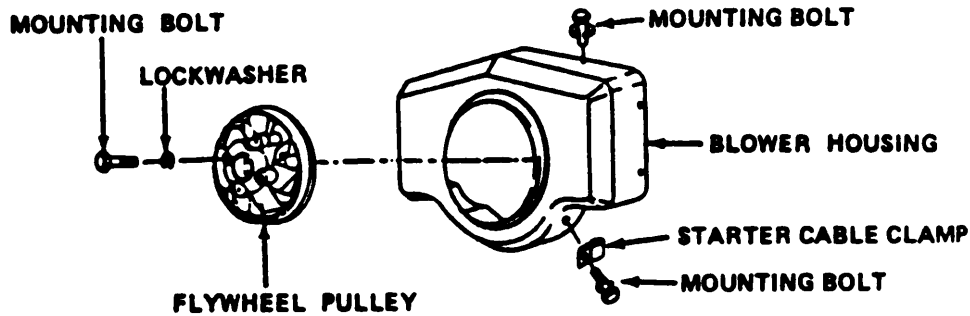

11 Install blower housing. Install eight blower housing mounting bolts and starter cable clamp.

12 Install flywheel pulley. Install two lockwashers and two flywheel pulley mounting bolts.

13 Install intake manifold (para 4-22).

14 Install carburetor (para 4-21).

4-26. DIPSTICK AND TUBE ASSEMBLY REPLACEMENT/REPAIR

This task covers:

a. Removal

b. Installation

INITIAL SETUP

Equipment

Condition

Para

Condition Description

Tools

4-8

Engine stopped, power disconnected, fuel line disconnected, muffler and housing removed.

General Mechanic's Tool Kit, item 1, appendix B

NOTE

Repair of the dipstick and tube assembly consists of replacement of the dipstick, tube, or seal.

4-26. DIPSTICK AND TUBE ASSEMBLY REPLACEMENT/REPAIR (CONT)

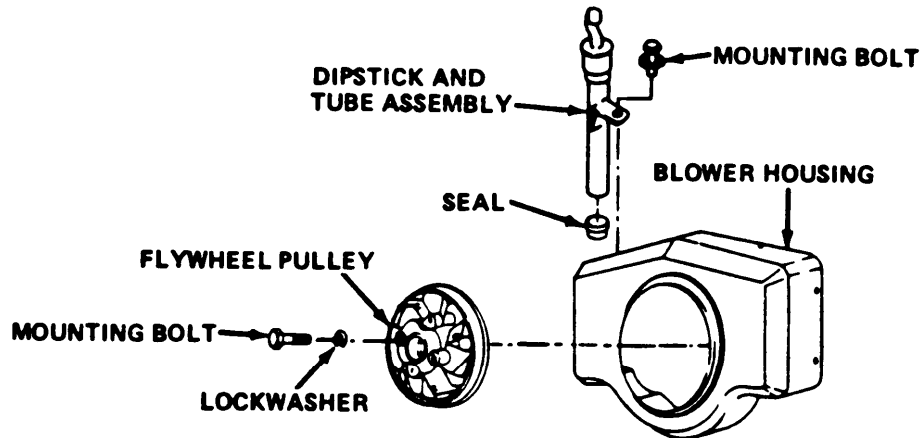
a. Removal

- 1 Remove two flywheel pulley mounting bolts and two lockwashers. Remove flywheel pulley.
- 2 Remove eight blower housing mounting bolts. Remove blower housing.
- 3 Remove dipstick from tube. Remove tube.
- 4 Remove seal from engine.

b. Installation

- 1 Install seal in engine.
- 2 Install tube. Install lockwasher and mounting bolt.
- 3 Insert dipstick in tube.
- 4 Install blower housing. Install eight blower housing mounting bolts.
- 5 Install flywheel pulley. Install two lockwashers and two flywheel pulley mounting bolts.

4-27. STARTER REPLACEMENT

This task covers:

- a. Testing
- b. Starter Cable Replacement
- c. Removal
- d. Installation

INITIAL SETUP

Equipment

Condition

<u>Para</u>	<u>Conbition Description</u>
4-8	Engine stopped, power disconnected, fuel line disconnected, muffler and housing removed.

Tools

- General Mechanic’s Tool Kit, item 1, appendix B
- Common No. 1 Organizational Maintenance Automotive Maintenance and Repair Shop Equipment, item 2, appendix B

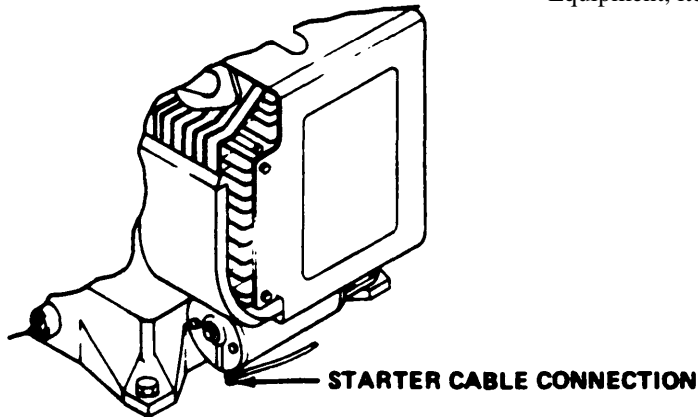

a. Testing

- 1 Insert power cable into 12/24 VOLT INPUT FOR STARTING connection.
- 2 Set multimeter for voltage test. Connect black lead to skid and red lead to starter cable connection.
- 3 Hold down starter button S7 and check multimeter display.
- 4 If no voltage present, test starter button (para 4--23).
- 5 If 12 volts are present and starter does not turn, replace starter.
- 6 Disconnect power cable.

4-27. STARTER REPLACEMENT (CONT)

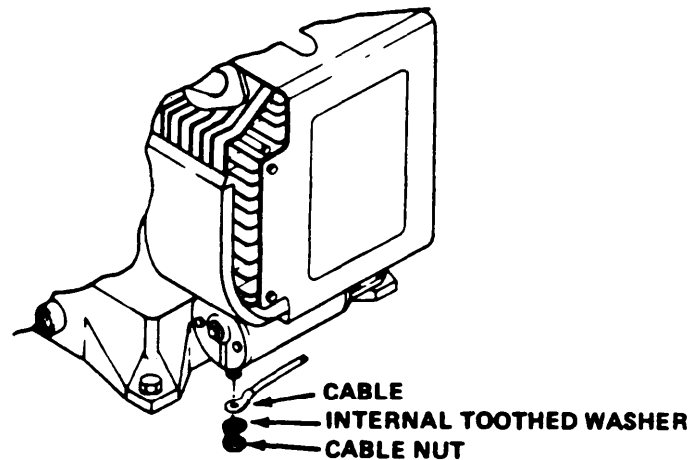
**WARNING**

To prevent electric shock, make sure power is disconnected from 12/24 VOLT INPUT FOR STARTING connection before performing this procedure.

b. Starter Cable Replacment

- 1 Remove cable nut and internal toothed washer from starter. Remove starter cable.
- 2 Remove starter cable mounting clamp bolt from blower housing. Remove starter cable mounting clamp from starter cable.
- 3 Remove starter cable mounting nut, lockwasher, and flatwasher from switch S7. Remove starter cable.
- 4 Install starter cable on switch S7. Install flatwasher, lockwasher, and starter cable mounting nut.
- 5 Install starter cable mounting clamp on starter cable. Install starter cable mounting clamp and bolt on blower housing.
- 6 Install starter cable on starter. Install internal toothed washer and cable nut on starter.

4-27. STARTER REPLACEMENT (CONT)

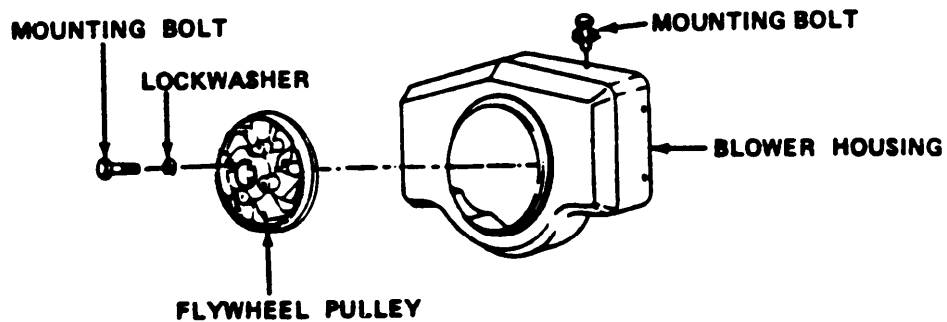

c. Removal

- 1 Remove two flywheel pulley mounting bolts and two lockwashers. Remove flywheel pulley.
- 2 Remove eight mounting bolts from blower housing. Remove blower housing.

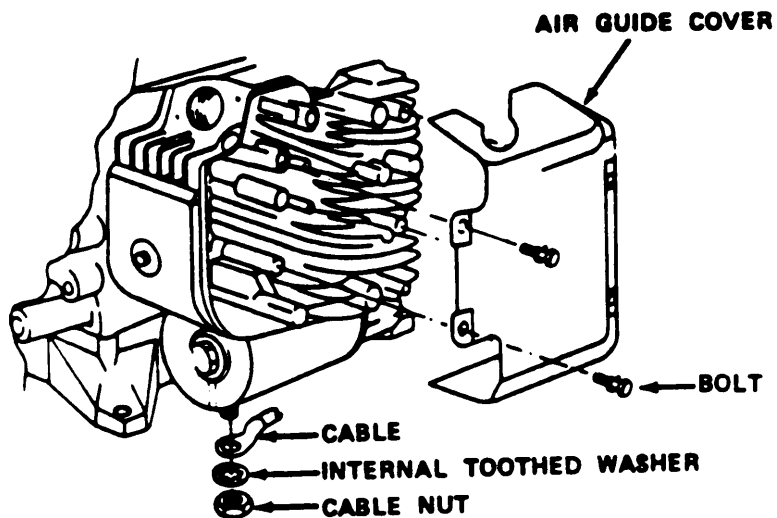

4-27. STARTER REPLACEMENT (CONT)

CAUTION

To prevent damage to cylinder shield and air guide cover, remove air guide cover slowly.

3 Remove two bolts from air guide cover. Remove air guide cover.

WARNING

To prevent electric shock, make sure power is disconnected from 12/24 VOLT INPUT FOR STARTING connection before removing cable nut.

4 Remove cable nut and internal toothed washer from starter.

5 Remove cable from starter.

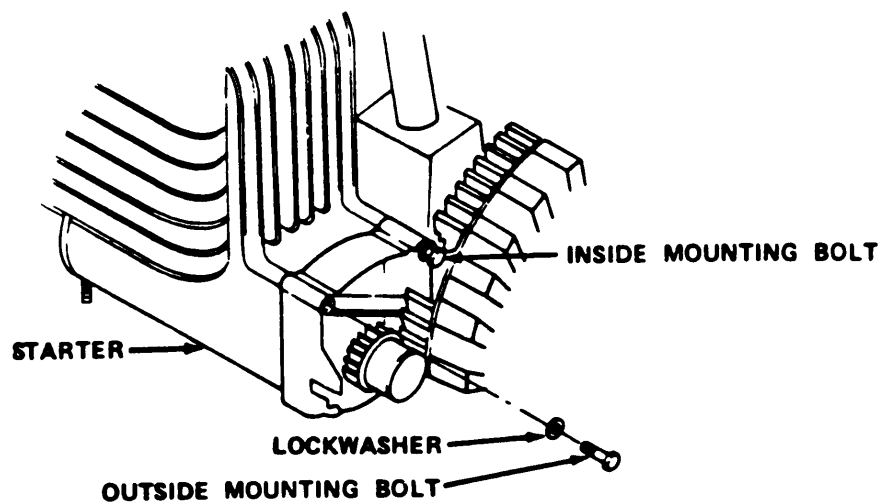
**NOTE**

Inside mounting bolt cannot be removed before starter is removed from engine.

6 Loosen inside mounting bolt.

4-27. STARTER REPLACEMENT (CONT)

CAUTION

To prevent damage to starter, place hand under starter to catch it as outside mounting bolt is removed.

- 7 Remove outside mounting bolt and lockwasher.
- 8 Remove starter. Remove inside mounting bolt and lockwasher.

d. Installation

- 1 Insert inside mounting bolt and lockwasher in starter. Install starter.
- 2 Install outside mounting bolt. Do not tighten.
- 3 Torque inside mounting bolt to 160 in. lb(217 Nm).
- 4 Torque outside mounting bolt to 160 in. lb (217 Nm).

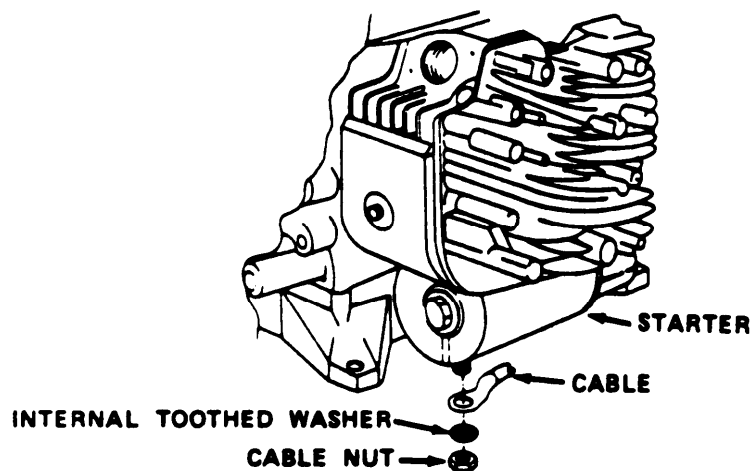

- 5 Install cable on starter.

WARNING

To prevent electric shock, make sure power is disconnected from 12/24 VOLT INPUT FOR STARTING connection before installing cable nut.

- 6 Install internal toothed washer and cable nut on starter.

4-27. STARTER REPLACEMENT (CONT)

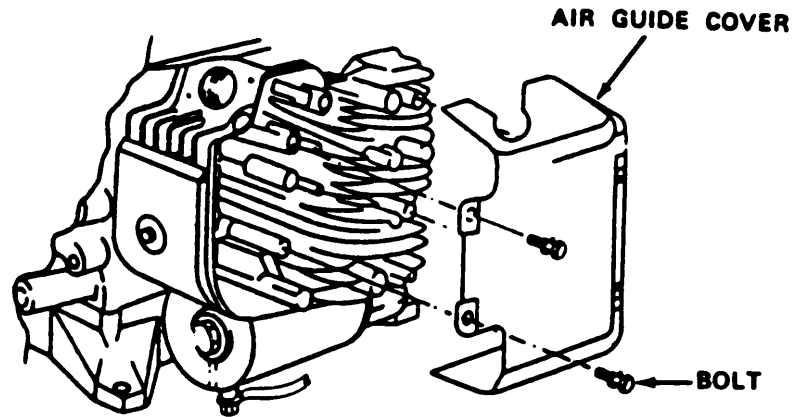

7 Install airguide cover. Install two bolts on air guid ecover.

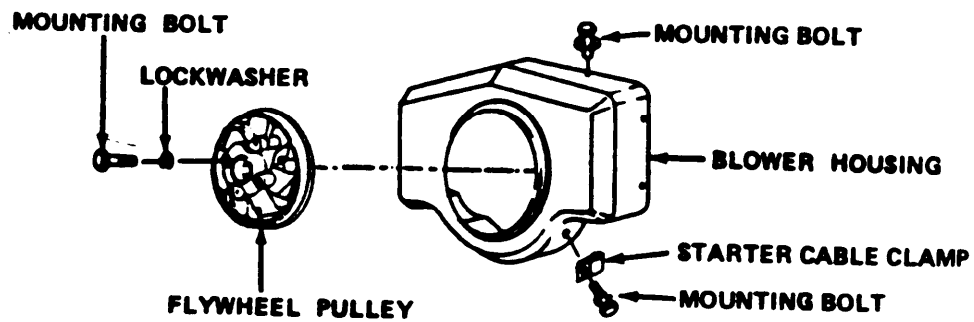

8 Install blower housing. Install eight blower housing mounting bolts and starter cable clamp.

9 Install flywheel pulley. Install two lockwashers and two flywheel pulley mounting bolts.

4-28. FLYWHEEL AND RING GEAR ASSEMBLY REPLACEMENT/REPAIR

This task covers:

- a. Disassembly
- b. Assembly

INITIAL SETUP

Equipment
Condition

<u>Para</u>	<u>Condition Description</u>	<u>Tools</u>
4-8	Engine stopped, power disconnected, fuel line disconnected, muffler and housing removed.	Common No. 1 Organizational Maintenance Automotive Maintenance and Repair Shop Eqpt, item 2, appendix B Block of wood

NOTE

Repair of the flywheel and ring gear assembly consists of replacement of worn or damaged parts.

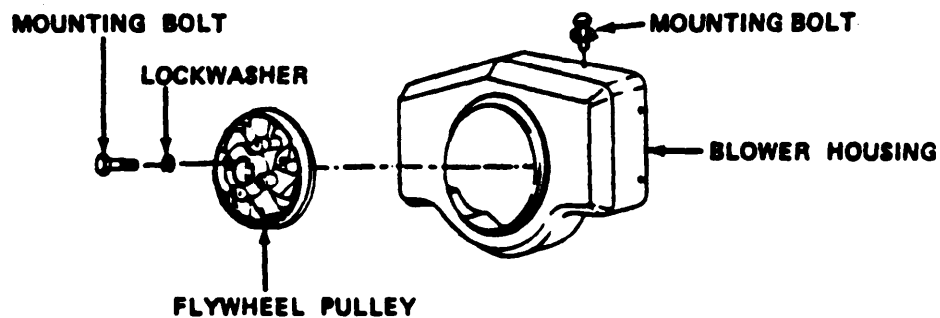

a. Disassembly

- 1 Remove two flywheel pulley mounting bolts and two lockwashers. Remove flywheel pulley.
- 2 Remove eight mounting bolts from blower housing. Remove starter cable clamp. Remove blower housing.

4-28. FLYWHEEL AND RING GEAR ASSEMBLY REPLACEMENT/REPAIR (CONT)

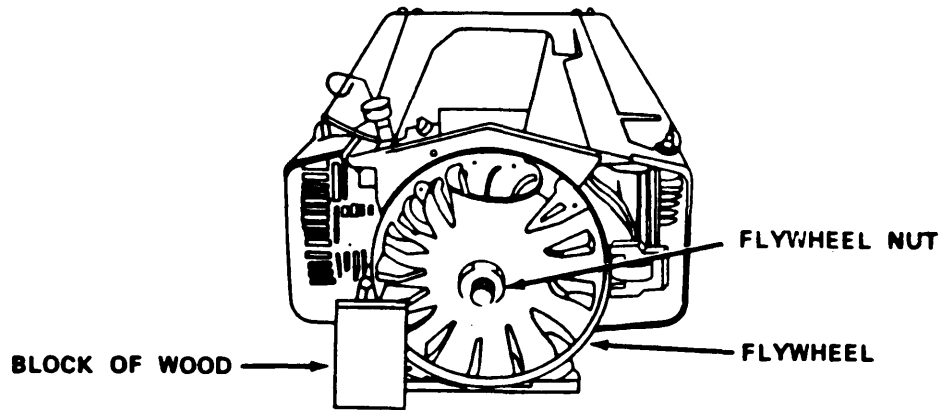

3 Place a block of wood under flywheel to prevent turning.

CAUTION

To prevent damage to flywheel or crankshaft, be sure to loosen flywheel nut before attaching puller.

4 Loosen flywheel nut until it is flush with the end of the crankshaft.

5 Loosen flywheel on crankshaft.

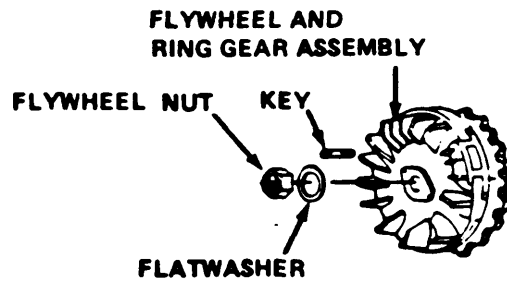

6 Remove flywheel nut and flatwasher.

7 Remove flywheel and ring gear assembly.

4-28. FLYWHEEL AND RING GEAR ASSEMBLY REPLACEMENT/REPAIR (CONT)

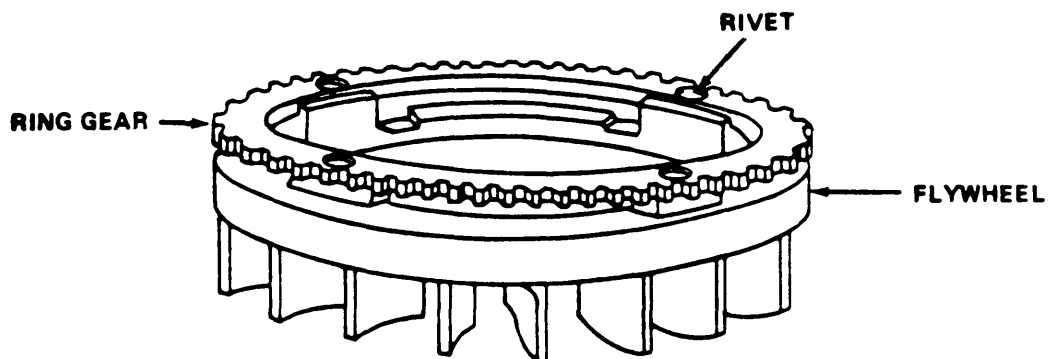

8 Inspect flywheel for worn keyway. Inspect ring gear for worn or missing teeth.

9 If removing ring gear from flywheel, place assembly on flat surface with ring gear side up.

10 Using centerpunch, mark the center of the four rivets holding the ring gear to the flywheel.

12 Drill out rivets. Clean holes after drilling.

13 Beat flywheel to soften epoxy holding ring gear.

14 Remove ring gear and clean epoxy from flywheel and ring gear.

4-28. FLYWHEEL AND RING GEAR ASSEMBLY REPLACEMENT/REPAIR (CONT)

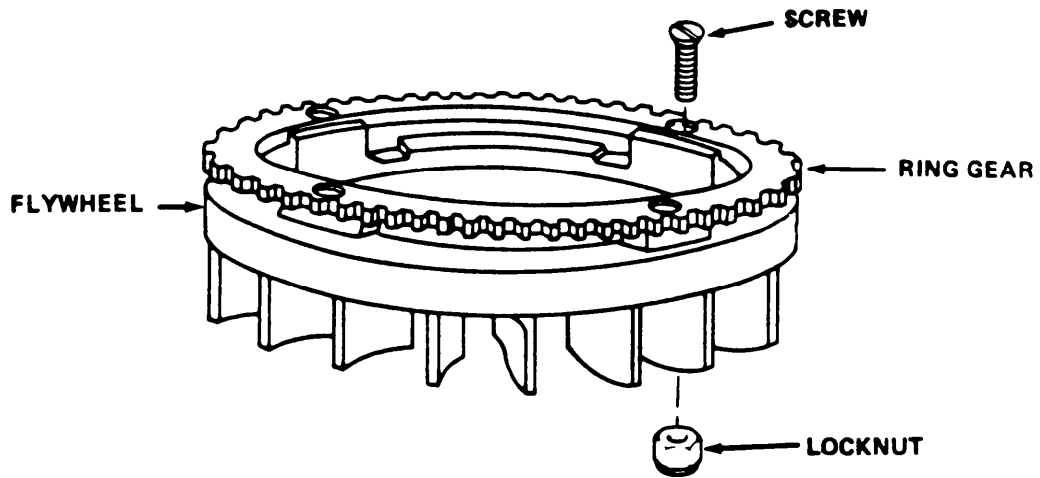

b. Assembly

- 1 Install ring gear on flywheel,
- 2 Install four screws and four locknuts.

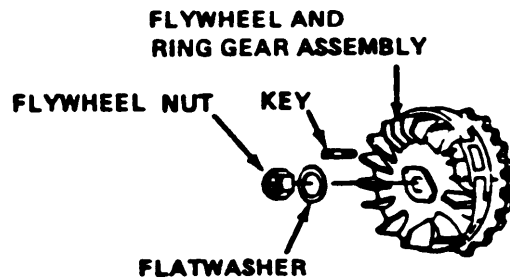

- 3 Install key in keyway of flywheel.
- 4 Install flywheel on crankshaft making sure to aline keyways.
- 5 Install flatwasher and flywheel nut.

4-28. FLYWHEEL AND RING GEAR ASSEMBLY REPLACEMENT/REPAIR (CONT)

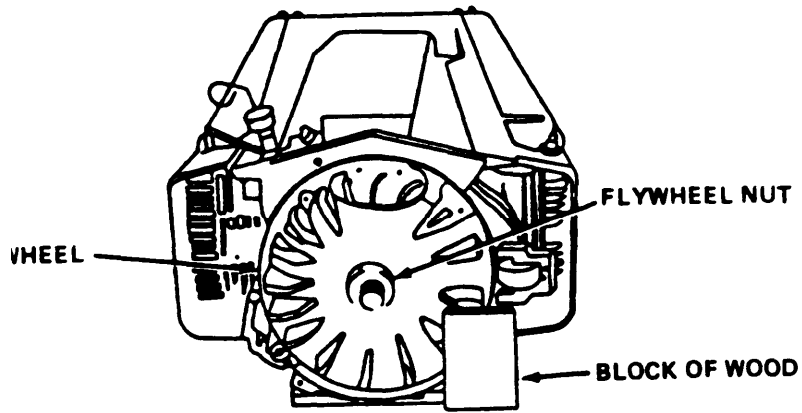

6 Place block of wood under flywheel to prevent turning.

7 Torque flywheel nut to 150 ft lb (203 Nm).

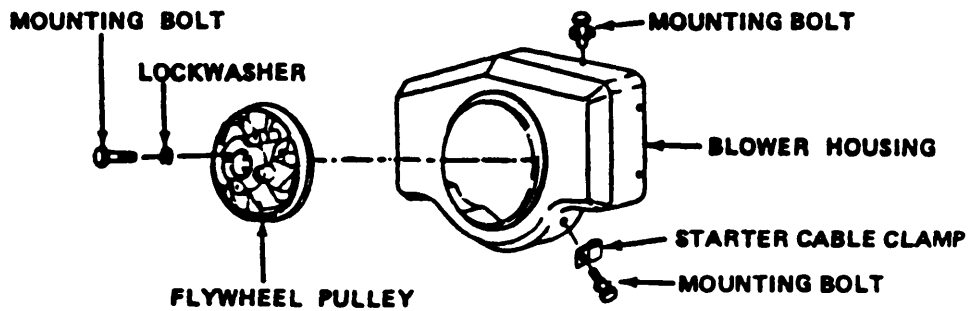

8 Install blower housing. Install eight blower housing mounting bolts and starter cable clamp.

9 Install flywheel pulley. Install two lockwashers and two flywheel pulley mounting bolts.

4-29. HIGH PRESSURE SWITCH CONTINUITY TEST

This task covers testing only.

INITIAL SETUP

Tools

Equipment

Condition

<u>Para</u>	<u>Condition Description</u>	<u>Tools</u>
4-8	Engine stopped, power disconnected, fuel line disconnected, muffler and housing removed.	Common No. 1 Organizational Maintenance Automotive Maintenance and Repair Shop Eqpt, item 2, appendix B

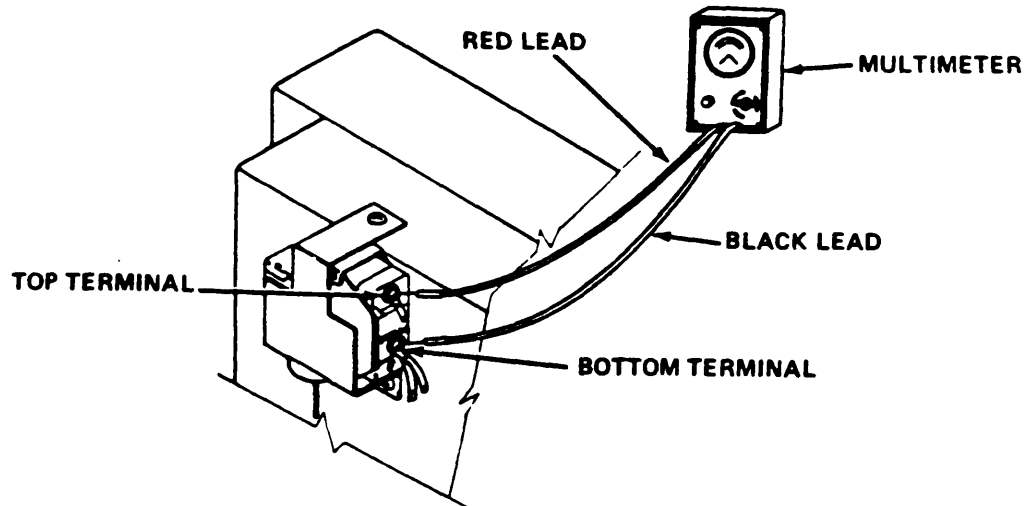

- 1 Prepare multimeter for continuity testing.
- 2 Place red lead of multimeter to top terminal of switch. Place black lead on bottom terminal of switch.
- 3 Multimeter should show greater than 1 ohm. If multimeter does not show proper continuity, notify direct support.

4-30. LOW PRESSURE SWITCH CONTINUITY TEST

This task covers testing only.

INITIAL SETUP

Equipment

Condition

<u>Para</u>	<u>Condition Description</u>	<u>Tools</u>
4-8	Engine stopped, power disconnected, fuel line disconnected, muffler and housing removed.	Common No. 1 Organizational Maintenance Automotive Maintenance and Repair Shop Eqpt, item 2 appendix B

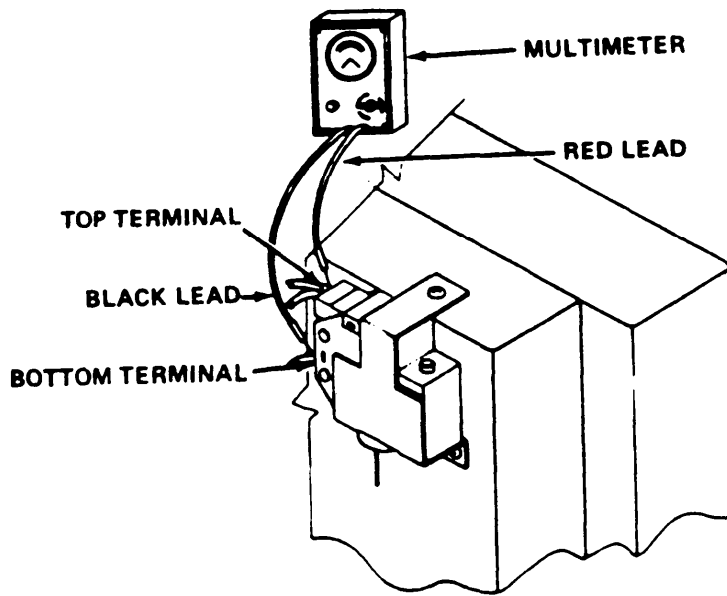

- 1 Prepare multimeter for continuity testing.
- 2 Hold red lead of multimeter to top terminal of switch. Place black lead on bottom terminal of switch.
- 3 Multimeter should show greater than 1 ohm. If multimeter does not show proper continuity, notify direct support.

4-31. WATER PUMP REPLACEMENT

This task covers:

a. Removal

b. Installation

INITIAL SETUP

Equipment

Condition

<u>Para</u>	<u>Condition Description</u>	<u>Tools</u>
4-8	Engine stopped, power disconnected, fuel line disconnected, muffler and housing removed.	General Mechanic's Tool Kit, item 1, appendix B

Materials/Parts

Tape, item 23, appendix E

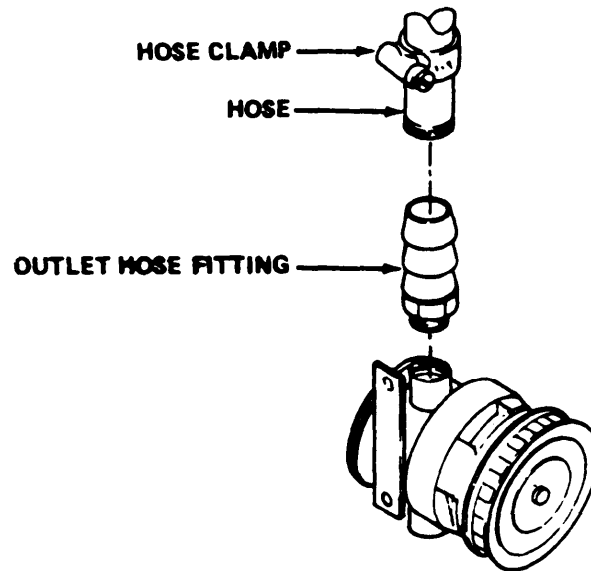

a. Removal

- 1 Pull back insulation on upper hose to expose hose clamp.
- 2 Loosen hose clamp. Remove hose from outlet hose fitting.
- 3 Remove outlet hose fitting from water pump.

4-31. WATER PUMP REPLACEMENT (CONT)

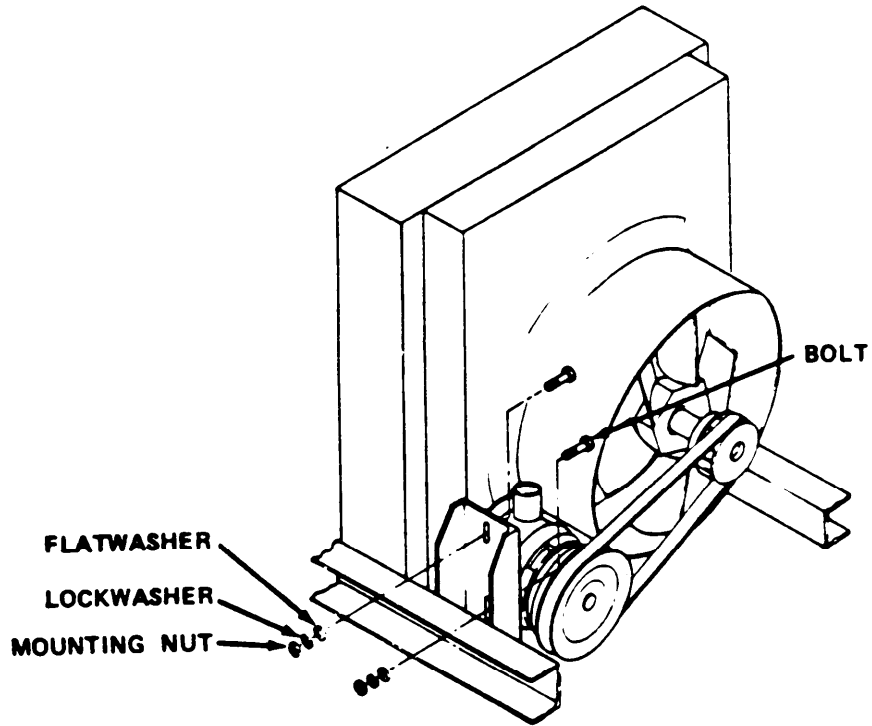

4 Remove two mounting nuts, two lockwashers, two flatwashers, and two bolts.

5 Lift and remove water pump drivebelt.

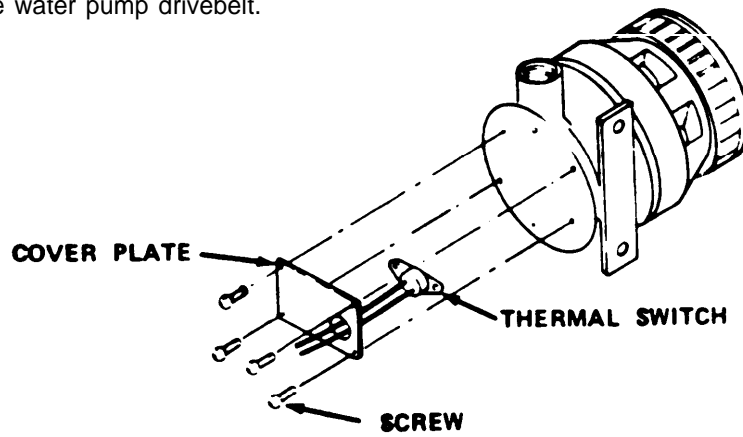

6 Tilt water pump to expose cover plate.

7 Remove four screws from cover plate.

8 Remove cover plate and thermal switch.

4-31. WATER PUMP REPLACEMENT (CONT)

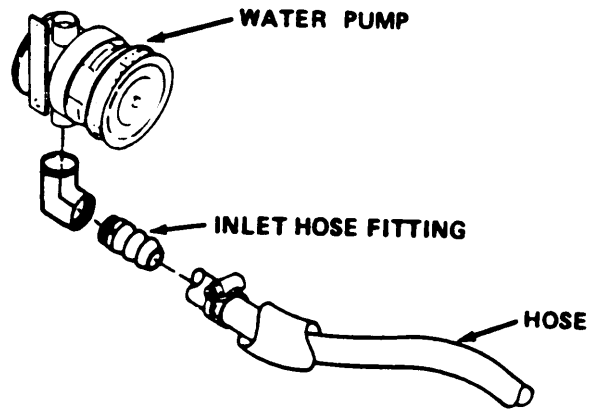

- 9 Pull back insulation on lower hose to expose hose clamp.
- 10 Loosen hose clamp.
- 11 Remove hose from fittings.
- 12 Remove water pump from water chiller.
- 13 Remove fittings.

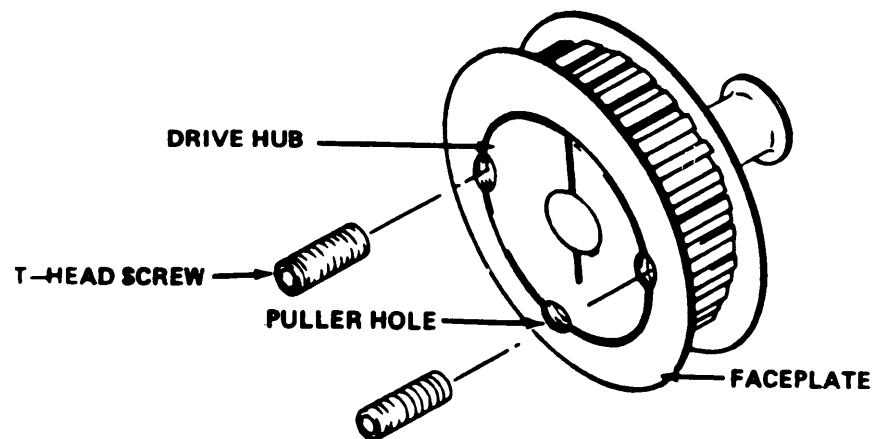

- 14 Remove two socket-head screws from water pump drive hub.
- 15 Install one socket-head screw in puller hole in water pump drive hub. Tighten socket-head screw while gently tapping on outer part of faceplate.

4-31. WATER PUMP REPLACEMENT (CONT)

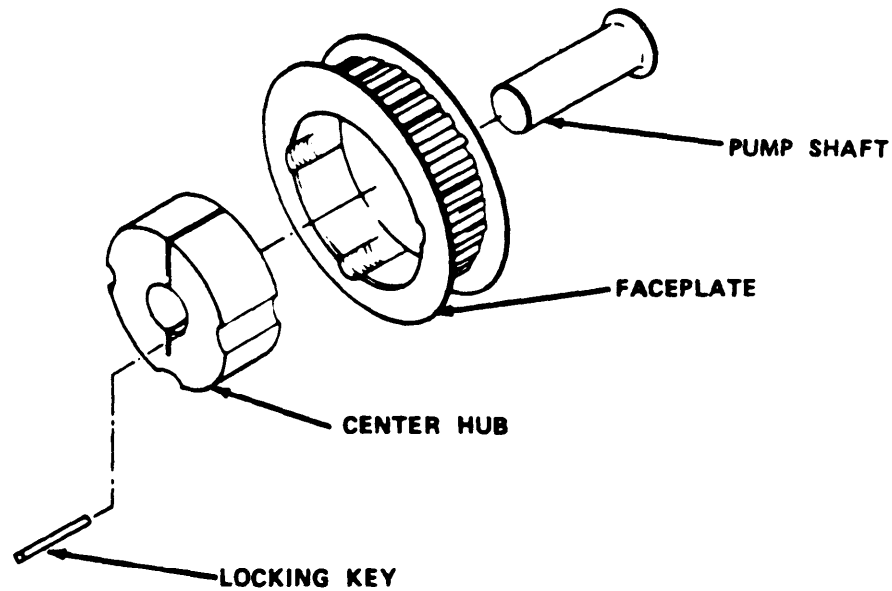

- 16 Tighten screw and continue tapping until faceplate can be pushed back toward water pump, free of center hub.
- 17 Remove center hub and locking key from pump shaft.
- 18 Remove faceplate from pump shaft.
- 19 Remove socket-head screw from puller hole.

b. Installation

NOTE

Side of faceplate with three screw holes faces away from pump.

- 1 Place outer faceplate on water pump shaft against body of water pump.

4-31. WATER PUMP REPLACEMENT (CONT)

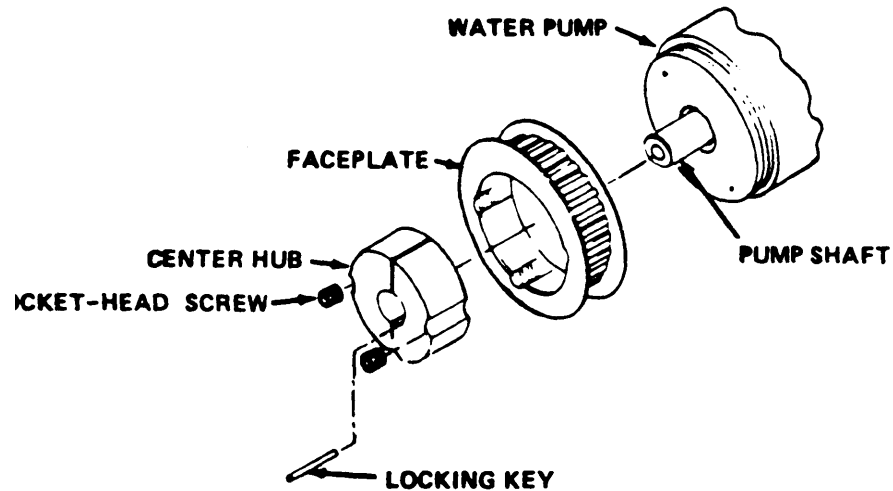

- 2 Place locking key in slot on water pump shaft.
- 3 Install center hub on end of water pump shaft in alignment with locking key.
- 4 While sliding center hub back on water pump shaft, place faceplate loosely on center hub.
- 5 Push water pump drive hub assembly back against water pump. Adjust to provide clearance of at least 0.010 in. (0.25 mm) between assembly and water pump.
- 6 Install two socket-head screws in faceplate.

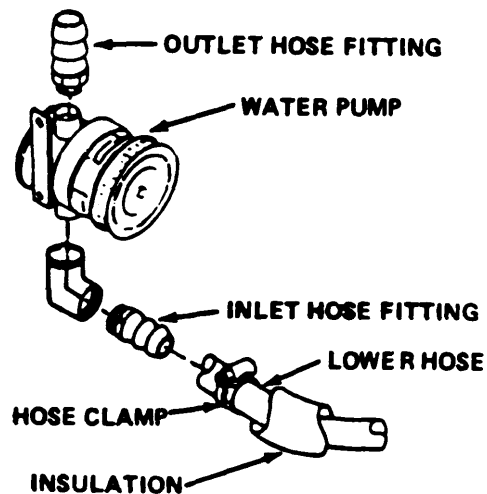

- 7 Wrap the threads of the water pump inlet and outlet hose fittings with tape.

4-31. WATER PUMP REPLACEMENT (CONT)

- 8 Install inlet and outlet hose fittings in water pump.
- 9 Position water pump in frame of water chiller.
- 10 Install lower hose and hose clamp on water pump inlet hose fitting.
- 11 Tighten hose clamp. pull insulation over hose clamp.

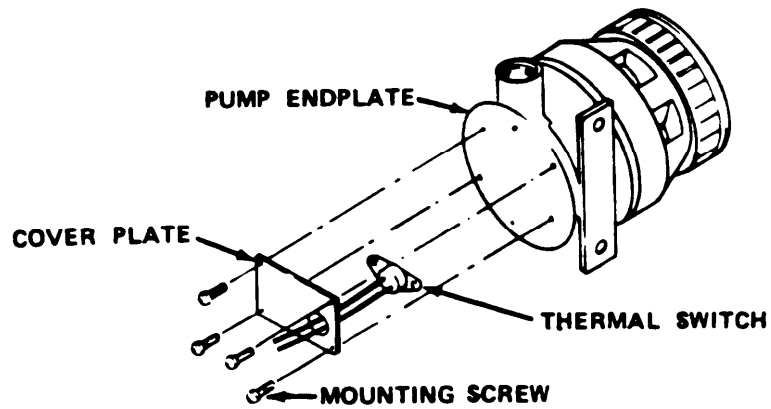

- 12 Install high temperature thermal switch and cover plate on pump endplate.
- 13 Install four switch bracket mounting screws.

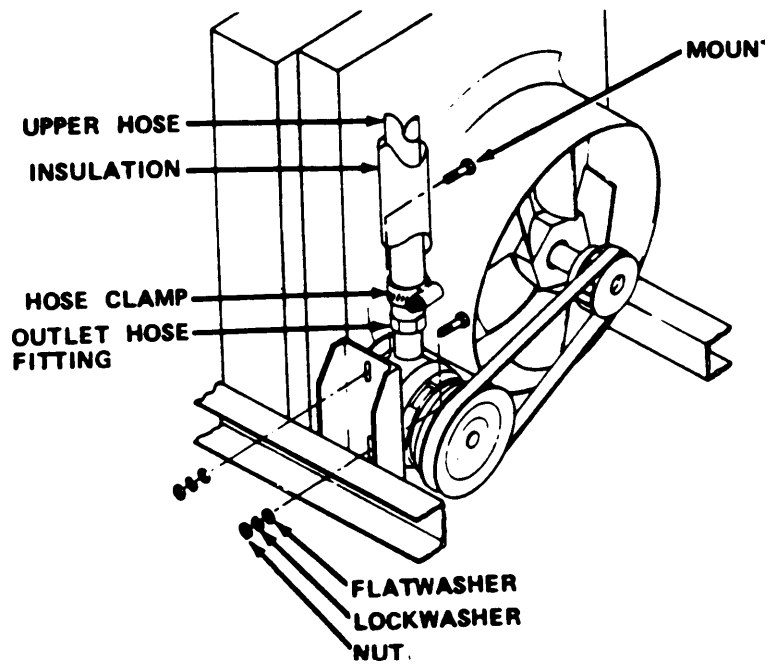

4-31. WATER PUMP REPLACEMENT (CONT)

- 14 Install two water pump mounting bolts, two flatwashers, two lockwashers, and two nuts. Do not tighten.
- 15 Pour potable water into water pump outlet hose fitting to wet impeller,
- 16 Install upper hose and hose clamp on water pump outlet hose fitting.
- 17 Tighten hose clamp. Pull insulation over hose clamp.
- 18 Install and adjust water pump drivebelt (para 4-13).

4-32. HIGH TEMPERATURE THERMAL SWITCH REPLACEMENT

This task covers:

- a. Testing
- b. Removal
- c. Installation

INITIAL SETUP

Equipment
Condition

<u>Para</u>	<u>Condition Description</u>	<u>Tools</u>
4-8	Engine stopped, power disconnected, fuel line disconnected, muffler and housing removed.	Common No. 1 Organizational Maintenance Automotive Maintenance and Repair Shop Eqpt, item 2, appendix B

Materials/Parts

Solder, item 20, appendix E

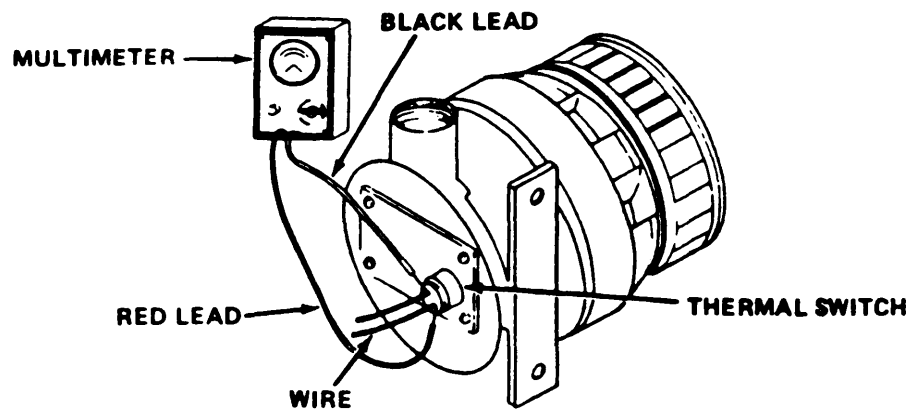

4-32. HIGH TEMPERATURE THERMAL SWITCH REPLACEMENT (CONT)

a. Testing

- 1 Check that water temperature is below 120°F (49°C).
- 2 Locate two terminals on back of high temperature thermal switch.
- 3 Place multimeter red lead on one terminal. Place black lead on other terminal. Multimeter should show more than 1 ohm.
- 4 If multimeter does not show more than 1 ohm, replace switch.

b. Removal

- 1 Perform steps 1 through 8 of paragraph 4-3 la.

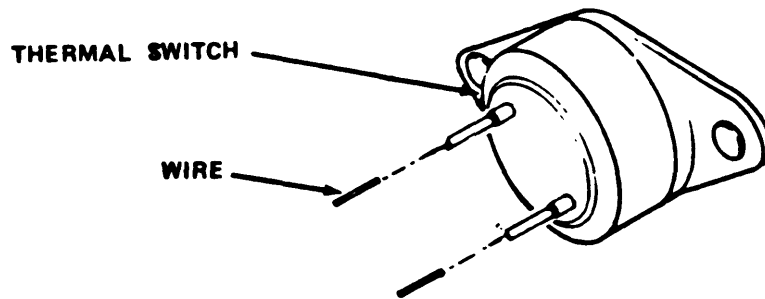

- 2 Desolder two wires from thermal switch. Remove thermal switch.

c. Installation

- 1 Install new thermal switch. Solder two wires to thermal switch terminals.
- 2 Perform steps 12 through 18 of paragraph 4-3 lb.

4-33. RELIEF VALVE REPAIR

This task covers:

- | | |
|----------------|---------------|
| a. Disassembly | c. Adjustment |
| b. Assembly | |

4-33. RELIEF VALVE REPAIR (CONT)

INITIAL SETUP

Equipment

Tools

Condition

General Mechanic's Tool Kit,
item 1, appendix B

Para

Condition Description

Materials/Parts

4-8

Engine stopped, power disconnected, fuel line disconnected, muffler and housing removed.

Pail, appendix D

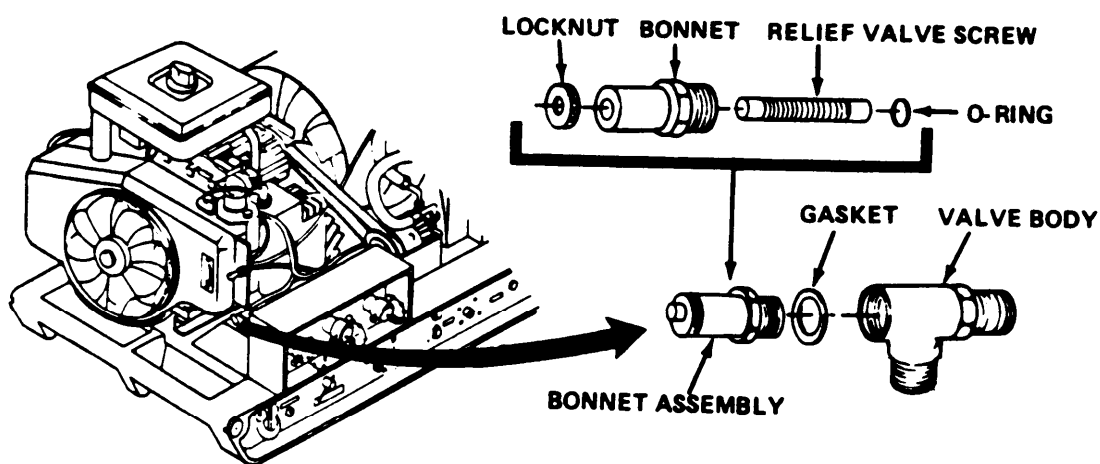

a. Disassembly

- 1 Remove bonnet assembly and gasket from valve body.
- 2 Remove locknut from relief valve screw.
- 3 Remove relief valve screw through inside of bonnet.
- 4 Remove O-ring from relief valve screw.

4-33. RELIEF VALVE REPAIR (CONT)

- 5 Remove spring, two spring retainers, and valve seat assembly from valve body.
- 6 Remove seat retainer and valve seat from valve.
- 7 Inspect all metal parts for wear or damage. Replace as needed.
- 8 Inspect O-ring and gasket for wear or damage. Replace as needed.

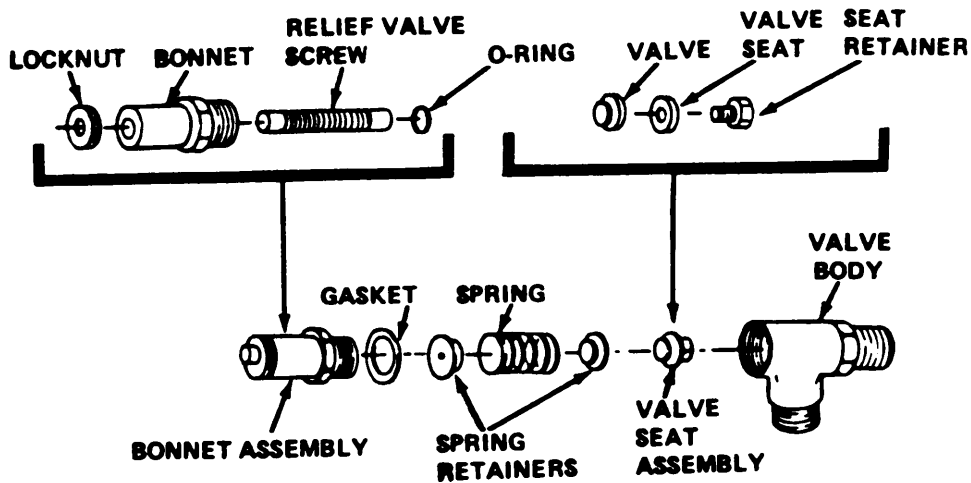

b. Assembly

- 1 Install O-ring on relief valve screw.
- 2 Install relief valve screw through inside of bonnet.
- 3 Install locknut on relief valve screw.
- 4 Install valve seat and seat retainer on valve.
- 5 Install valve seat assembly in valve body.
- 6 Install lower spring retainer in valve body.
- 7 Install spring and upper spring retainer in valve body.
- 8 Install gasket and bonnet assembly in valve body.

4-32. RELIEF VALVE REPAIR (CONT)

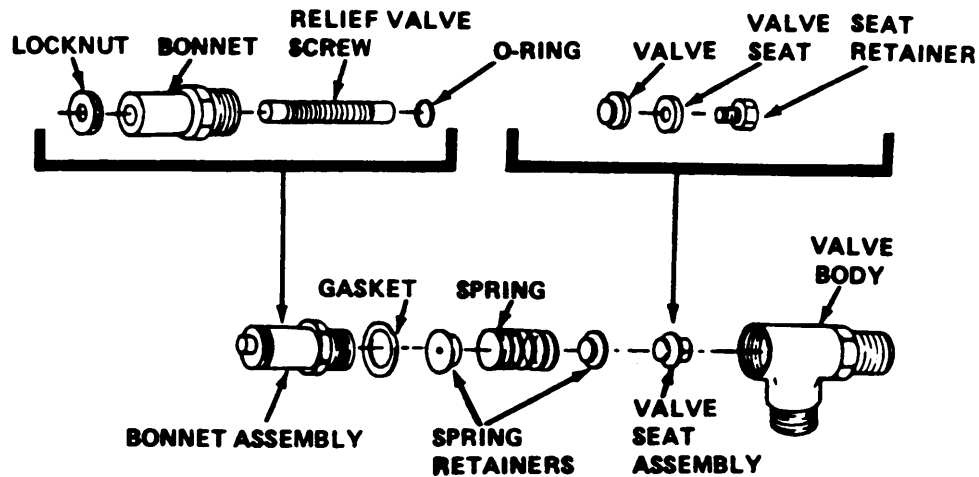
c. Adjustment

- 1 Loosen locknut on relief valve.
- 2 Startup water chiller (para 2-6a). Turn START RUN water control to START position. Dispense water from relief valve into a 1-gallon (3.8-liter) pail.
- 3 Measure time it takes to fill pail. If relief valve is properly adjusted, it should take 10 seconds to fill pail.
- 4 Turn relief valve screw right to decrease flow. Turn left to increase flow.
- 5 Adjust until proper flow rate is achieved.
- 6 Tighten locknut on relief valve, being careful not to disturb adjustment of relief valve screw.

4-34. LOW TEMPERATURE THERMAL SWITCH TEST

This task covers testing only.

INITIAL SETUP

Tools

Equipment

Condition

Para

Condition Description

Tools

4-8

Engine stopped, power disconnected, fuel line disconnected, muffler and housing removed.

Common No. 1 Organizational Maintenance Automotive Maintenance and Repair Shop Eqpt, item 2 appendix B

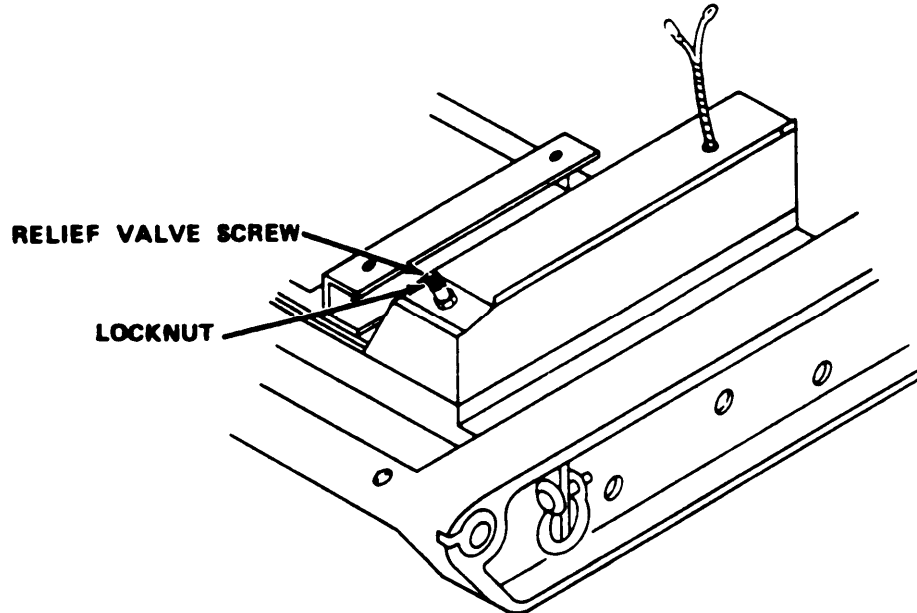

- 1 Check that water supply temperature is above 65°F (18°C).
- 2 Locate two wires which run from low temperature thermal switch where they exit skid.
- 3 Place multimeter red lead on one wire. Place black lead on other wire. Multimeter should show more than 1 ohm.
- 4 If multimeter does not show more than 1 ohm, notify direct support to replace switch.

4-35. VEHICLE RECEPTACLE ASSEMBLY REPLACEMENT

This task covers:

- a. Testing
- b. Removal
- c. Installation

INITIAL SETUP

Equipment

Condition

<u>Para</u>	<u>Condition Description</u>	<u>Tools</u>
4-8	Engine stopped, power disconnected, fuel line disconnected, muffler and housing removed.	Common No. 1 Organizational Maintenance Automotive Maintenance and Repair Shop Eqpt, item 2 appendix B General Mechanic's Tool Kit, item 1, appendix B

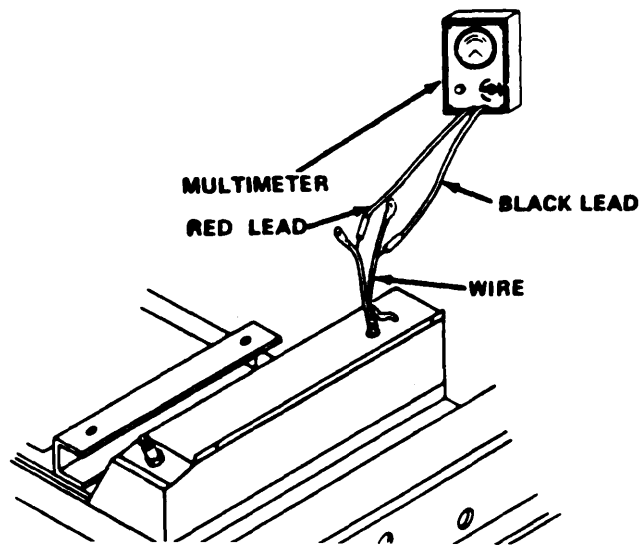

a. Testing

- 1 Using multimeter, check power cable for 12 volts. If correct voltage is present, go to step 2. If correct voltage is not present, obtain correct voltage before going to next step.
- 2 Connect power cable to 12/24 INPUT FOR STARTING connection.
- 3 Using multimeter, check back of 12/24 input for starting connection for 12 volts. If correct voltage is not present replace receptacle.

4-35. VEHICLE RECEPTACLE ASSEMBLY REPLACEMENT (CONT)

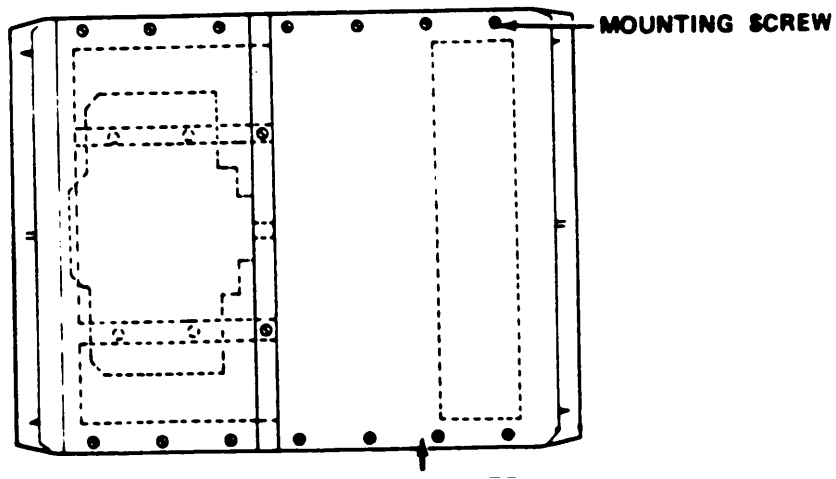

b. Removal

- 1 Drain engine oil (para 3-1).
- 2 Turn water chiller on its side with vehicle receptacle assembly up.
- 3 Remove 16 bottom plate mounting screws. Remove bottom plate.

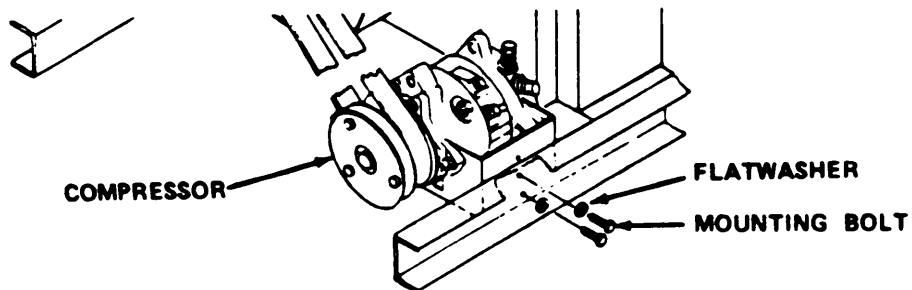

- 4 Remove two compressor bracket mounting bolts and two flatwashers. Move compressor aside.

4-35. VEHICLE RECEPTACLE ASSEMBLY REPLACEMENT (CONT)

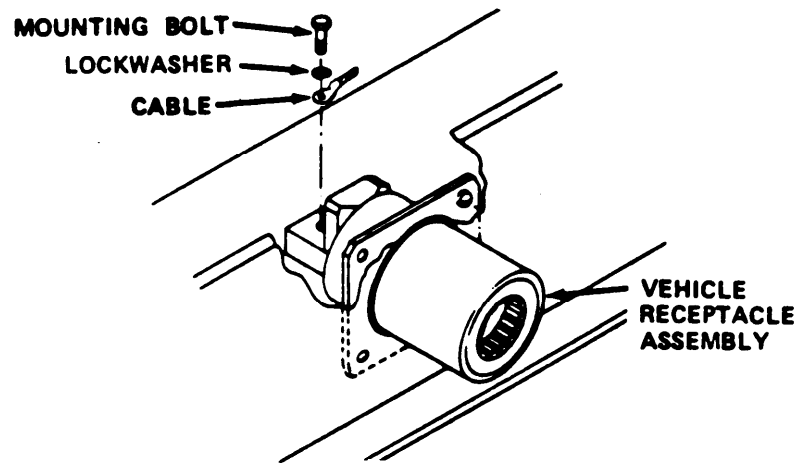

5 Remove cable mounting bolt and lockwasher from vehicle receptacle assembly.

6 Remove cable.

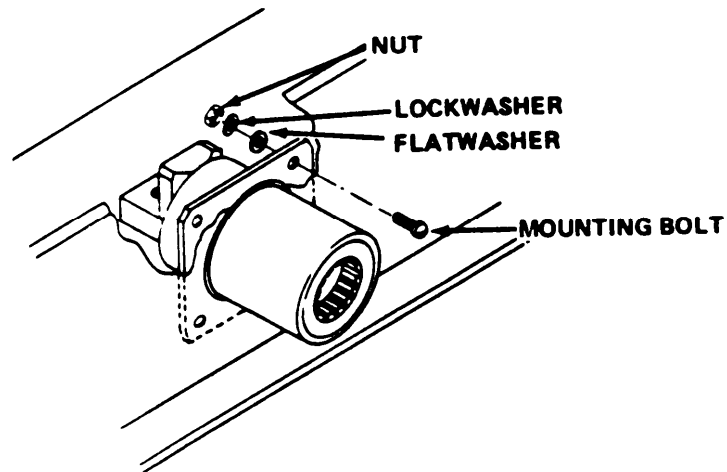

7 Remove four vehicle receptacle assembly mounting bolts, four flatwashers, four lockwashers, and four nuts.

8 Remove vehicle receptacle assembly.

4-35. VEHICLE RECEPTACLE ASSEMBLY REPLACEMENT (CONT)

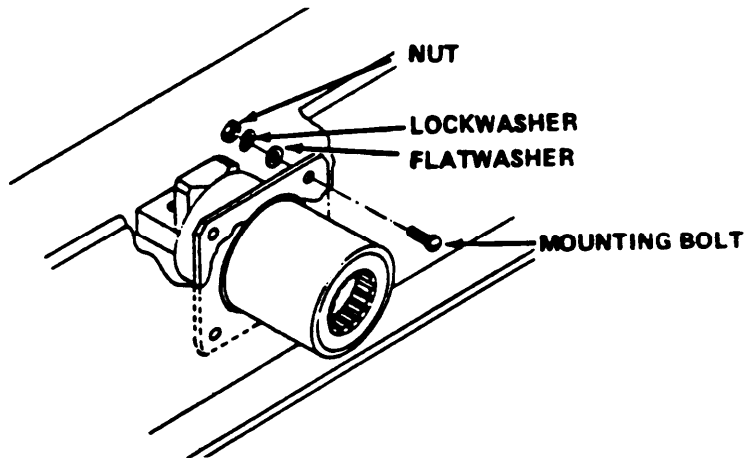

c. Installation

- 1 Place vehicle receptacle assembly in proper position in skid.
- 2 Install four mounting bolts, four flatwashers, four lockwashers, and four nuts.

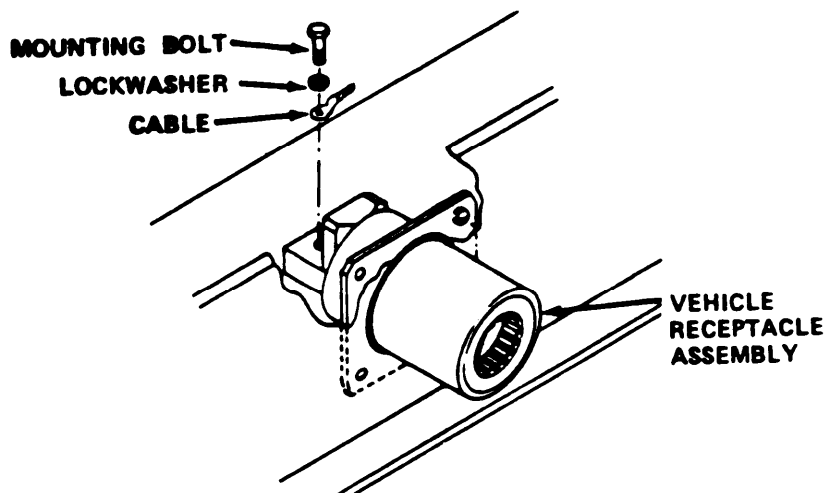

- 3 Install electric cable in vehicle receptacle assembly.
- 4 Install lockwasher and cable on mounting bolt. Install mounting bolt.

4-35. VEHICLE RECEPTACLE ASSEMBLY REPLACEMENT (CONT)

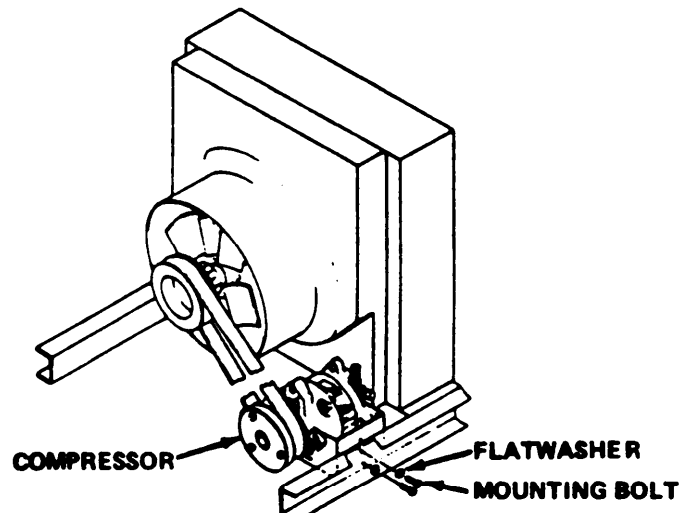

5 Aline compressor bracket with mounting holes. Install compressor bracket mounting bolts and flatwashers.

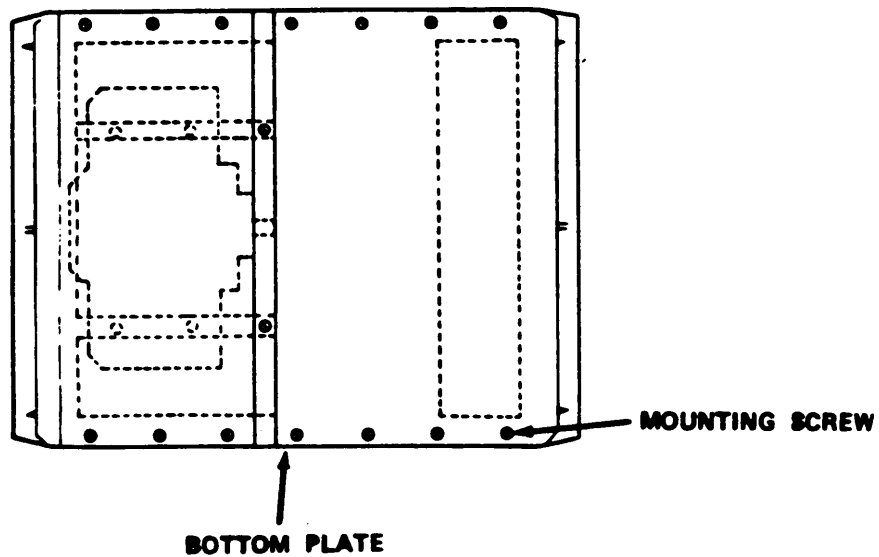

6 Install bottom plate Install 16 bottom plate mounting screws.

7 Turn water chiller upright.

8 Adjust compressor drivebelt (para 4-14),

9 Add engine oil (para 3-1).

4-36. SKID REPAIR

This task covers:

- a. Removal of Carrying Handle
- b. Installation of Carrying Handle

INITIAL SETUP

Tools

Equipment

Condition

<u>Para</u>	<u>Condition Description</u>	<u>Tools</u>
4-8	Engine stopped, power disconnected, fuel line disconnected, muffler and housing removed.	General Mechanic's Tool Kit, item 1, appendix B

NOTE

Repair of the skid consists of replacement of damaged carrying handles.

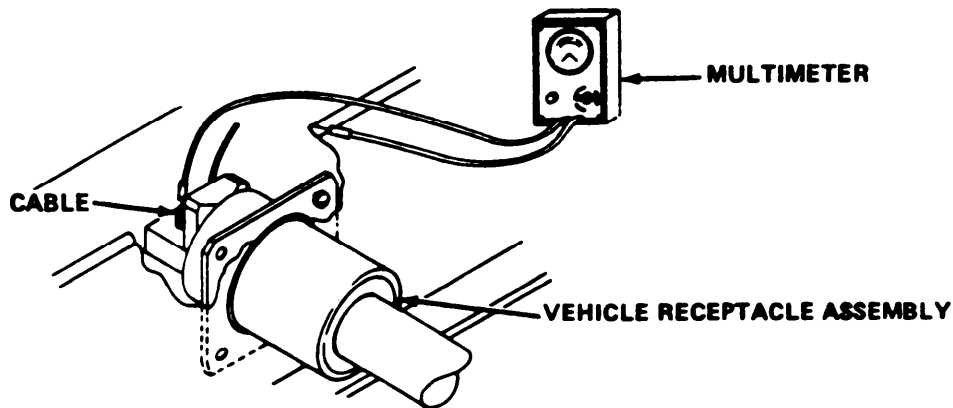

a. Removal of Carry Handles

- 1 Pull out retaining pin. Leave handle in extended position.
- 2 Remove retaining pin chain mounting screw and flatwasher.
- 3 Remove retaining pin assembly.
- 4 Remove handle retaining screw.
- 5 Remove handle and spring. Remove spring from end of handle.

4-35. SKID REPAIR (CONT)

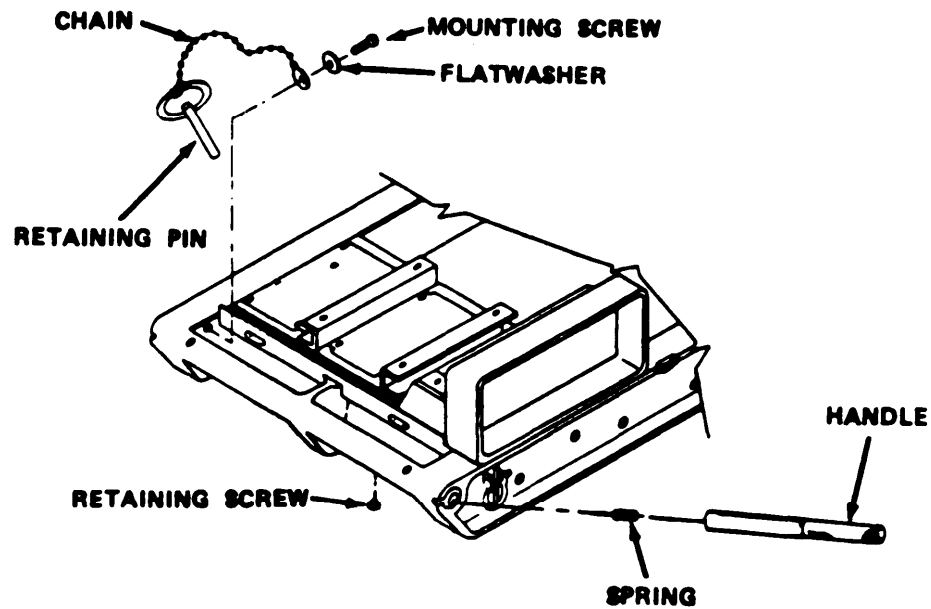
b. Installation of Carrying Handle

- 1 Insert spring in end of handle.
- 2 Install handle and spring in skid with retaining screw slot down.
- 3 Install handle retaining screw.
- 4 With handle in retracted position, insert retaining pin through skid and handle. Handle should now remain in retracted position.
- 5 Install retaining pin chain on skid assembly.
- 6 Install retaining pin chain flatwasher and mounting screw.

4-37. TRAILER MOUNTING KIT REPAIR

This task covers:

- a. Removal and Disassembly of Load Binders
- b. Installation and Assembly of Load Binders

INITIAL SETUP

Equipment

Condition

Para	Condition Description	Tools
4-8	Engine stopped, power disconnected, fuel line disconnected, muffler and housing removed.	Common No. 1 Organizational Maintenance Automotive Maintenance and Repair Shop Eqpt, item 2, appendix B

NOTE

Repair of the trailer mounting kit consists of replacement of damaged load binders.

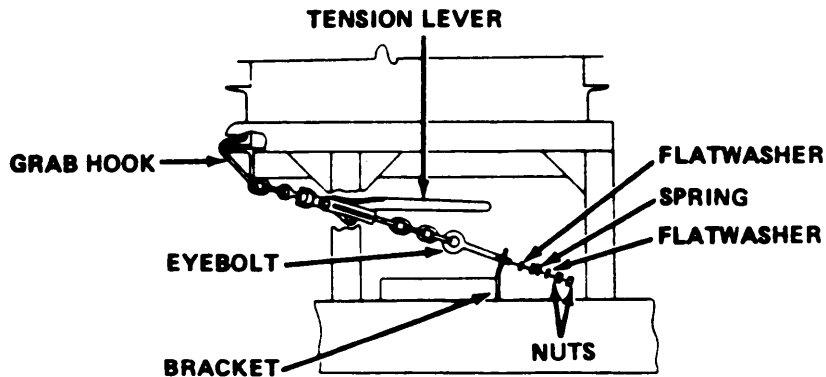

a. Removal and Disassembly of Load Binders

- 1 Release tension on load binder tension lever.
- 2 Remove two nuts from end of load binder eyebolt.
- 3 Remove two flatwashers and spring and remove eyebolt from eyebolt bracket.
- 4 Remove remainder of load binder from cradle.
- 5 Using punch, disassemble chain links. Disconnect grab hook, load binder, and eyebolt.

4-37. TRAILER MOUNTING KIT REPAIR (CONT)

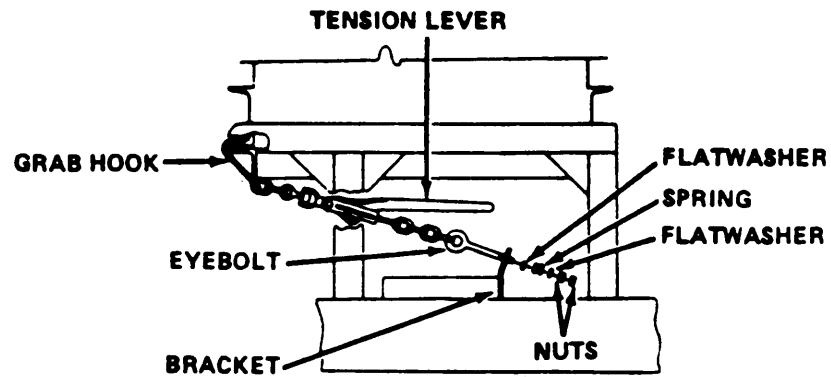
b. Installation of Load Binders

- 1 Install and fasten chain links between grab hook, load binder, and eyebolt.
- 2 Release tension on load binder tension lever. Install eyebolt through eyebolt bracket.
- 3 Install two flatwashers, spring, and two nuts on eyebolt.
- 4 Tighten tension on load binder tension lever.
- 5 Tighten nuts on eyebolt as needed to produce desired tension.

4-38. MODIFIED TRAILER MOUNTING KIT REPAIR

This task covers:

- a. Removal and Disassembly of Cradle
- b. Installation and Assembly of Cradle

Equipment

Condition

<u>Para</u>	<u>Condition Description</u>	<u>Tools</u>
2-7	Water chiller removed from cradle	Common No. 1 Organizational Maintenance Automotive Maintenance and Repair Shop Eqpt, item 2, appendix B

NOTE

Repair of the trailer mounting kit consists of replacement of damaged components.

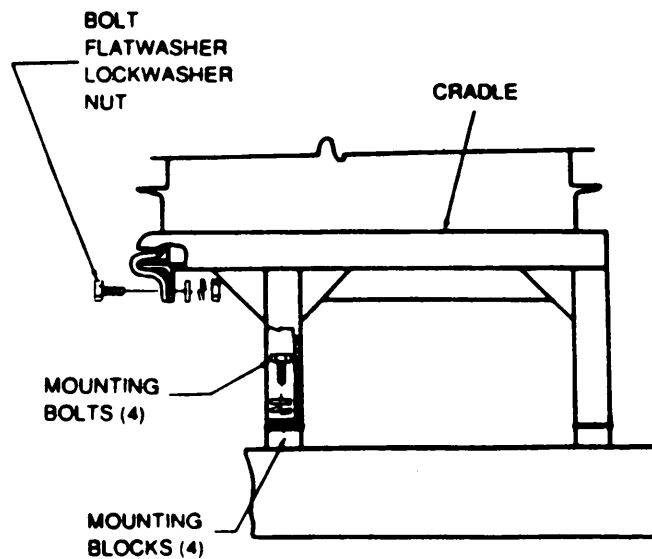

a. Removal and Disassembly of Cradle

1. Remove four mounting bolts attaching cradle to mounting blocks.
2. Remove cradle from trailer.

4-38. MODIFIED TRAILER MOUNTING KIT REPAIR (CONT)

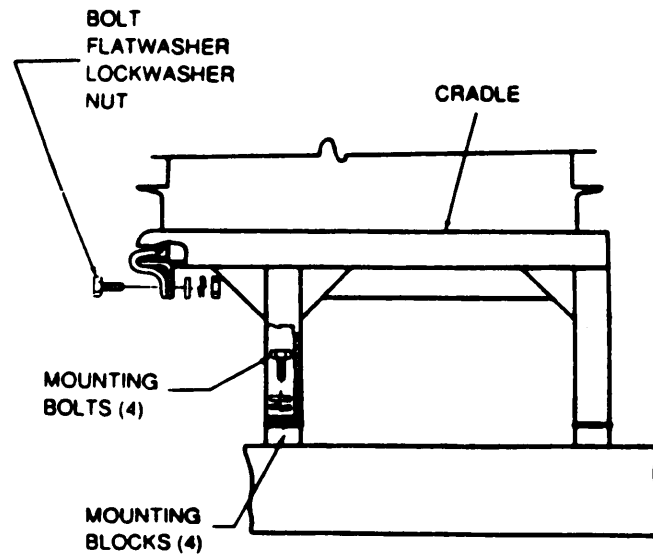

b. Installation of Cradle

1. Place cradle on mounting blocks.
2. Attach cradle with four mounting bolts, flatwashers and lockwashers to mounting blocks.

4-39. SUPPORT KIT REPAIR

This task covers:

- | | |
|--|-------------------------|
| a. Repair of Fuel Hose/Replacement of Fuel Filter or Primer Bulb | b. Repair of Water Hose |
|--|-------------------------|

INITIAL SETUP

Tools

General Mechanic's Tool Kit, item 1,
appendix B

4-39. SUPPORT KIT REPAIR (CONT)

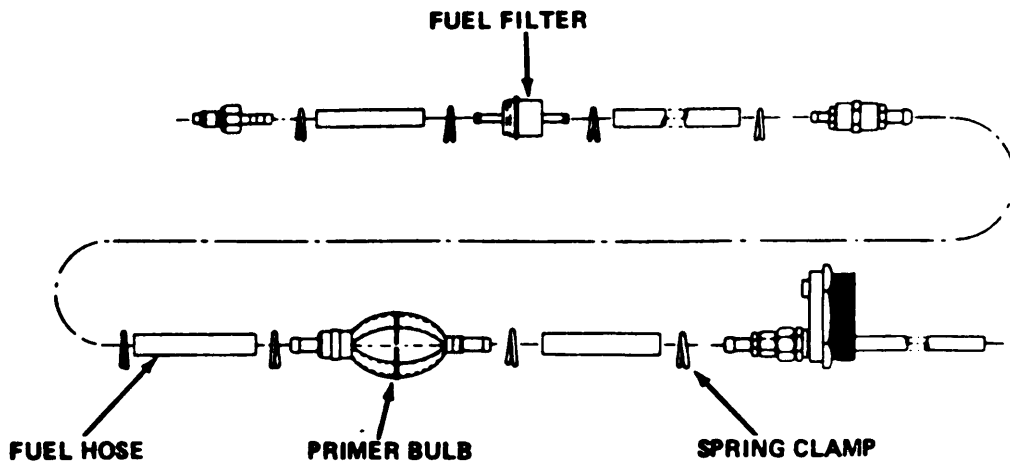

a. Repair of Fuel Hose/Replacement of Fuel Filter or Primer Bulb

- 1 Remove spring clamps. Remove fuel hose, fuel filter, or primer bulb.
- 2 Install new fuel filter or primer bulb. Replace fuel hose with bulk hose.
- 3 Install spring clamps.

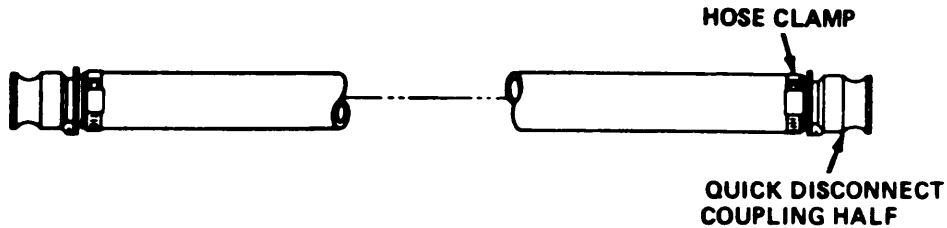

b. Repair of Water Hose

- 1 Loosen hose clamp. Remove quick-disconnect coupling half from hose.
- 2 Remove hose clamp. Place hose clamp on new hose section.
- 3 Install quick-disconnect coupling half in new hose.
- 4 Install hose clamp over quick--disconnect coupling half.

Section VI. PREPARATION FOR STORAGE OR SHIPMENT

4-40. STORAGE AND SHIPMENT INSTRUCTIONS

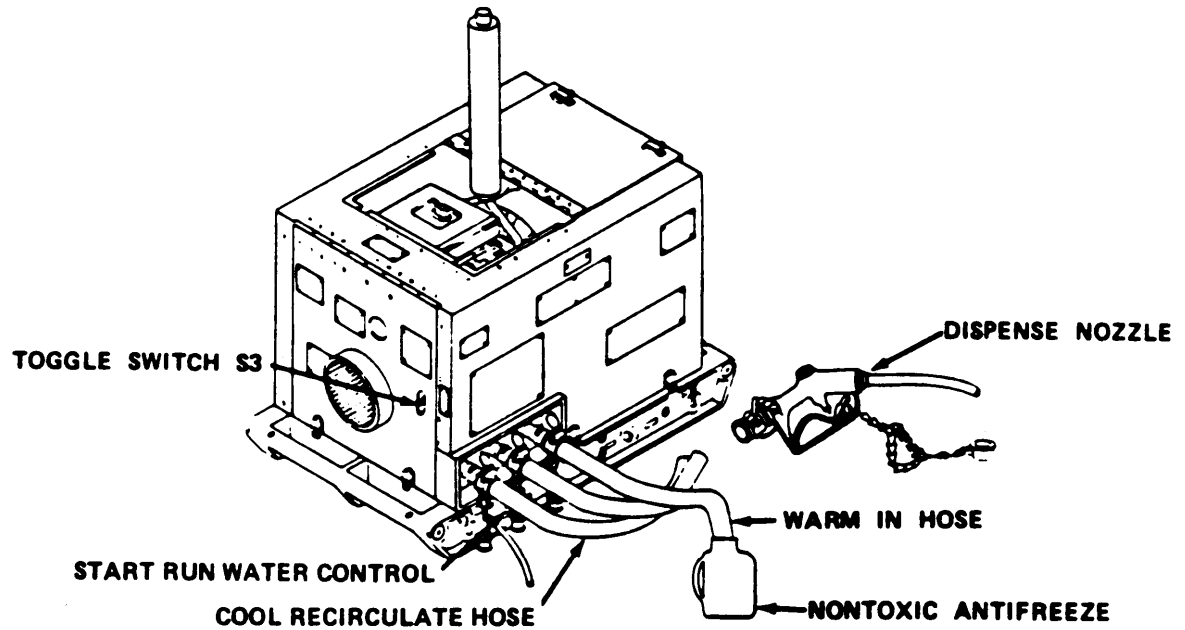

- 1 Disconnect warm in and cool recirculate hoses from water storage tank. Place end of warm in hose in container of nontoxic antifreeze (item 2, appendix E).
- 2 Start up engine (para 2-6a).
- 3 Open dispense nozzle.
- 4 When antifreeze begins to run horn nozzle and cool recirculate hose, hold toggle switch S3 in STOP position until engine stops, then release. Place START RUN water control in START position.

4-40. STORAGE AND SHIPMENT INSTRUCTIONS (CONT)

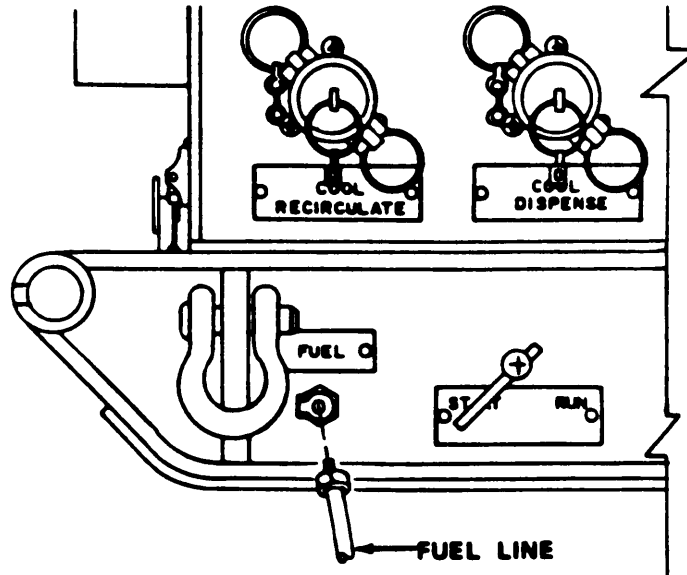

5 Disconnect fuel line from chiller and from fuel supply. Cover ends of fuel line to prevent entrance of debris.

6 Start engine (para 2-6a). Let run until it stops.

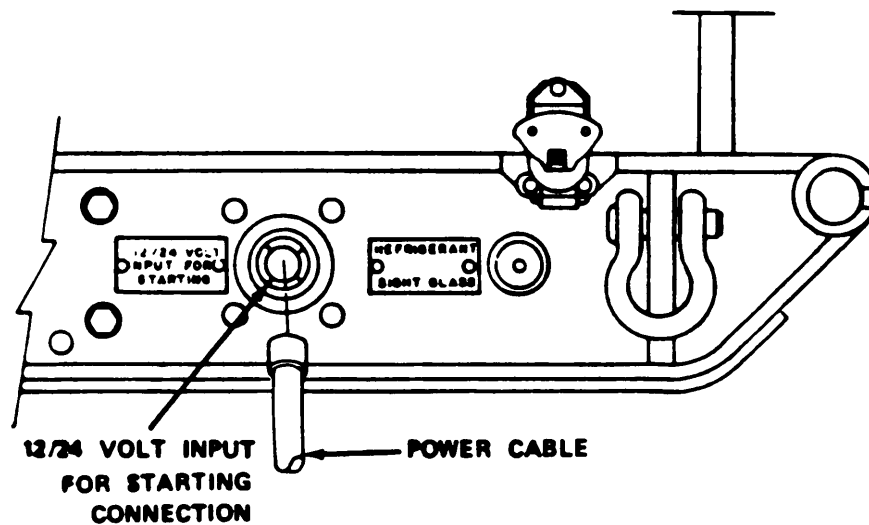

7 If needed, disconnect power cable from 12/24 VOLT INPUT FOR STARTING connection.

4-40. STORAGE AND SHIPMENT INSTRUCTIONS (CONT)

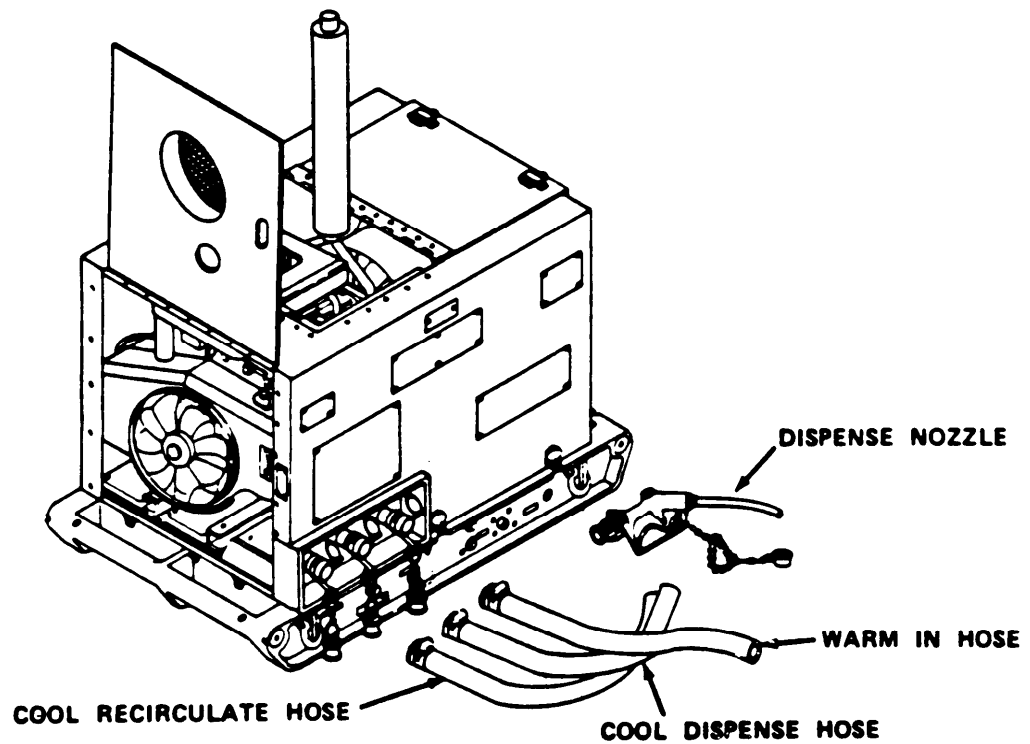

8 Remove warm in hose from water chiller and antifreeze container. Remove cool dispense and cool recirculate hoses from water chiller.

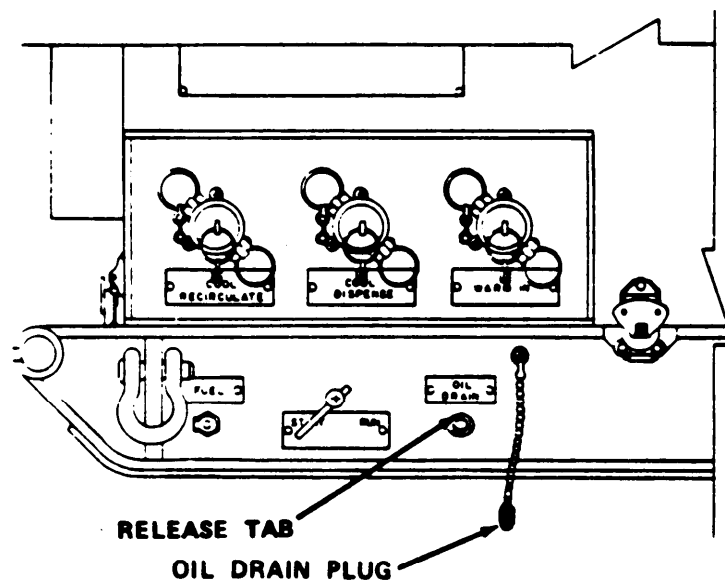

4-40. STORAGE AND SHIPMENT INSTRUCTIONS (CONT)

- 9 Drain all hoses. Cover hose ends to prevent entrance of debris.
- 10 With engine still warm, place oil drain pan (appendix D) under OIL DRAIN.
- 11 Press release tab, pull plug, and let oil drain. Install plug. Discard waste oil.
- 12 Pull out dipstick. Fill engine with 3.5 pints (1 .65 liters) of oil (MIL-L-46152, item 10, appendix E) through tube. Reinstall dipstick.

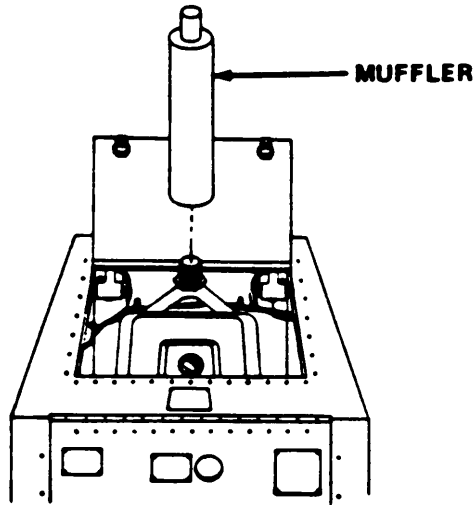

WARNING

To prevent burns, DO NOT try to remove muffler until it cools down.

- 13 Remove muffler.
- 14 Place hoses, dispense nozzle, fuel line, and muffler in support kit duffle bag.

4-40. STORAGE AND SHIPMENT INSTRUCTIONS (CONT)

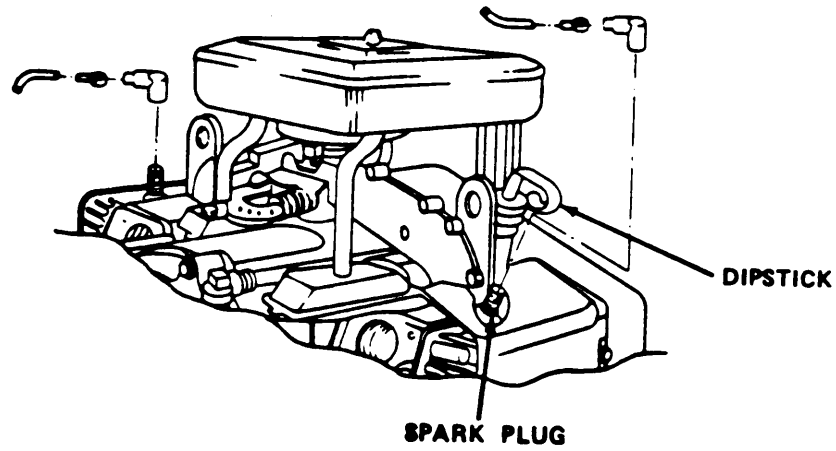

15 Remove spark plugs and pour 1 oz (30 cc) of oil (MIL-L-46152, item 10, appendix E) into each cylinder. Crank slowly to distribute oil. Install two spark plugs.

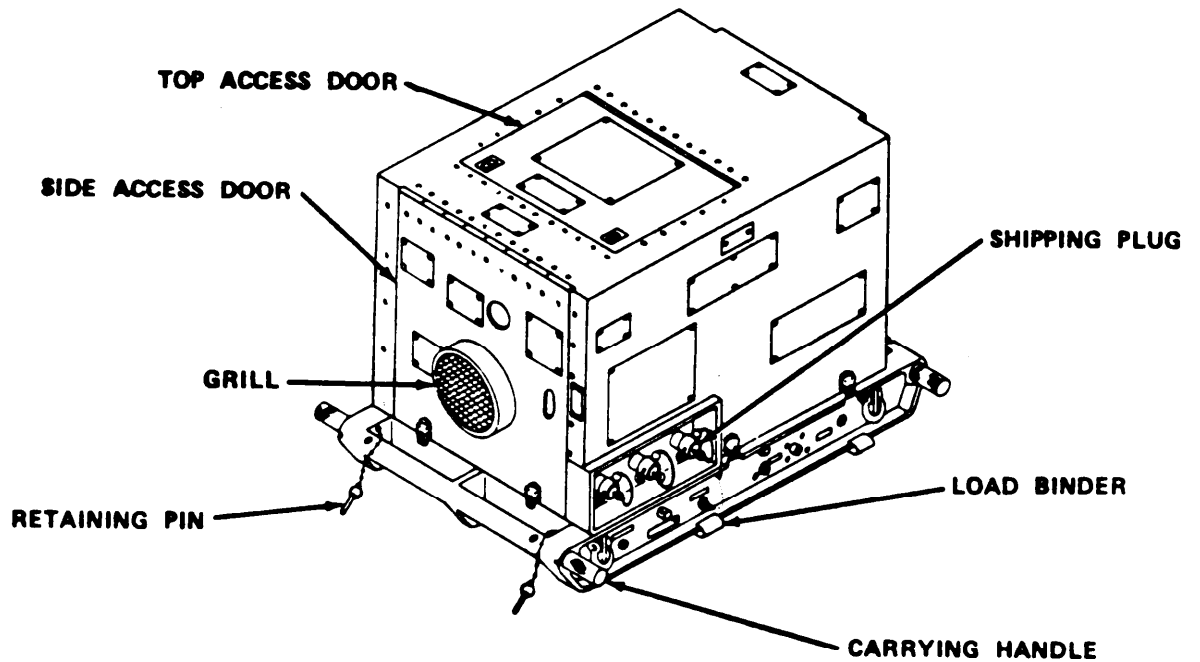

16 Clean all debris from grills.

17 Close and fasten top and side access doors.

4-40. STORAGE AND SHIPMENT INSTRUCTIONS (CONT)

18 Insert shipping plugs in water openings and secure in place.

19 If water chiller is mounted on trailer, disconnect two load binders.

20 Pull out four retaining pins. Pull out four carrying handles.

WARNING

To prevent personal injury, four persons required to lift water chiller.

21 If mounted on trailer, slide water chiller out of trailer mounting kit.

22 Place water chiller in shipping container.

23 Place support kit components in shipping container.

4-41. ADMINISTRATIVE STORAGE

a. Storage Length and Readiness. Placement of equipment in administrative storage should be for short periods of time (1 to 45 days) when a shortage of maintenance efforts exists. Items should be in mission readiness within 24 hours or within the time factors as determined by the directing authority. During the storage period, appropriate maintenance records will be kept.

b. Prior to Placing Unit in Storage. Before placing equipment in administrative storage, perform the next monthly/quarterly preventive maintenance checks and services. All shortcomings and deficiencies should be corrected, and all Modification Work Orders (MWOs) should be applied.

c. Storage Site Selection. Inside storage is preferred for items selected for administrative storage. If inside storage is not available, the sites selected should provide required protection from the elements and allow access for visual inspection when applicable.

**CHAPTER 5
DIRECT SUPPORT MAINTENANCE**

Section L DIRECT SUPPORT TROUBLESHOOTING

	Para	Para
General	5-1	

Section II. DIRECT SUPPORT MAINTENANCE PROCEDURES

General	5 - 2	Compressor Replacement	5-17
Carburetor Repair	5 - 3	Compressor Repair	5-18
Starter Repair	5 - 4	Filter Drier Replacement	5-19
Cylinder Heads Replacement	5 - 5	Water System Leak Test	5-20
Cylinder Block Assembly Replacement .	5 - 6	Water Pump Repair	5-21
Refrigeration System Leak-Test	5 - 7	Evaporator Replacement	5-22
Refrigeration System Pressure Test . . .	5 - 8	Relief Valve Replacement	5-23
Refrigeration System Service	5 - 9	Thermostatic Valve Replacement	5-24
Compressor Suction Hose Replacement ..	5-10	Thermostatic Valve Repair	5-25
Compressor Discharge Hose Replacement	5-11	Ball Valve Assembly Replacement . . .	5-26
High Pressure Switch Replacement	5-12	Low Temperature Thermal Switch	
Low Pressure Switch Replacement . . .	5-13	Replacement	5-27
Condenser Replacement	5-14	Trailer Mounting Kit Installation	5-28
Pressure Relief Valve Replacement	5-15	Modified Trailer Mounting Kit	
Expansion Valve Replacement	5-16	Installation	5-29

Section I. TROUBLESHOOTING

5-1. GENERAL. Table 5-1, Troubleshooting, lists common malfunctions which may be found during normal operation or during an inspection, check procedure, or scheduled testing. Perform the tests/inspections and corrective actions in order listed. This manual cannot list all malfunctions that may occur or list all tests/inspections and corrective actions. If a malfunction occurs that is not listed or covered in corrective action, notify your supervisor.

Table 5-1. Troubleshooting

MALFUNCTION

TEST OR INSPECTION

CORRECTIVE ACTION

1. ENGINE STOPS SUDDENLY.

Step 1. Test high and low pressure switch assemblies for continuity (para 4-29 and 4-30).

Replace switch (para 5-12 or 5-13).

Step 2. Test low temperature thermal switch for continuity (para 4-34).

Replace switch (para 5-27).

2. WATER LEAKS FROM FOAMED-IN SECTION OF SKID.

Step 1. Check for cracked evaporator.

Replace evaporator (para 5-22).

Step 2. Check for leak at thermostatic valve.

Replace thermostatic valve (para 5-24).

Step 3. Check for leaking ball valve.

Replace ball valve (para 5-26).

3. ENGINE SMOKES EXCESSIVELY OR LEAKS OIL.

Step 1. Test of engine assembly (para 4-19).

Replace cylinder block assembly (para 5-6).

Step 2. Check cylinder block assembly for cracks.

Replace cylinder block assembly (para 5-6).

Step 3. Check cylinder block for leaking seals and gaskets.

Replace cylinder block assembly (para 5-6).

Section II. DIRECT SUPPORT MAINTENANCE PROCEDURES**5-2. GENERAL**

a. Scope. This section contains direct support maintenance instructions authorized by the Maintenance Allocation Chart (MAC), appendix B, and by the source, maintenance, and recoverability (SMR) coded items to support the water chiller.

b. Equipment Conditions. Unless otherwise specified, perform all maintenance under the following conditions:

- Water chiller shut down.

WARNING

To prevent electric shock, be very careful when disconnecting power from 12/24 VOLT INPUT FOR STARTING connection.

- Power cable disconnected from 12/24 VOLT INPUT FOR STARTING connection.

WARNING

Fuel is flammable. To prevent fire or explosion, DO NOT bring sparks or open flame near fuel line.

- Fuel line disconnected.
- Exhaust muffler (para 4-18) and housing (para 4-9) removed.

After performing maintenance

- Install housing (para 4-9) and exhaust muffler (para 4-18).
- If needed, reconnect power cable to 12/24 VOLT INPUT FOR STARTING connection.

5-3. CARBURETOR REPAIR

This task covers:

- a. Disassembly
- b. Servicing
- c. Assembly

INITIAL SETUP

Equipment

Condition

<u>Para</u>	<u>Condition Description</u>	<u>Tools</u>
5-2	Engine stopped, power disconnected, fuel line disconnected, muffler and housing removed.	General Mechanic's Tool Kit, item 1, appendix B
4-20	Air cleaner elements removed.	Solvent, item 21, appendix E
4-21	Carburetor removed.	

NOTE

During disassembly of the carburetor, parts should be inspected for wear and damage. Replace any worn or damaged parts. Replace all gaskets.

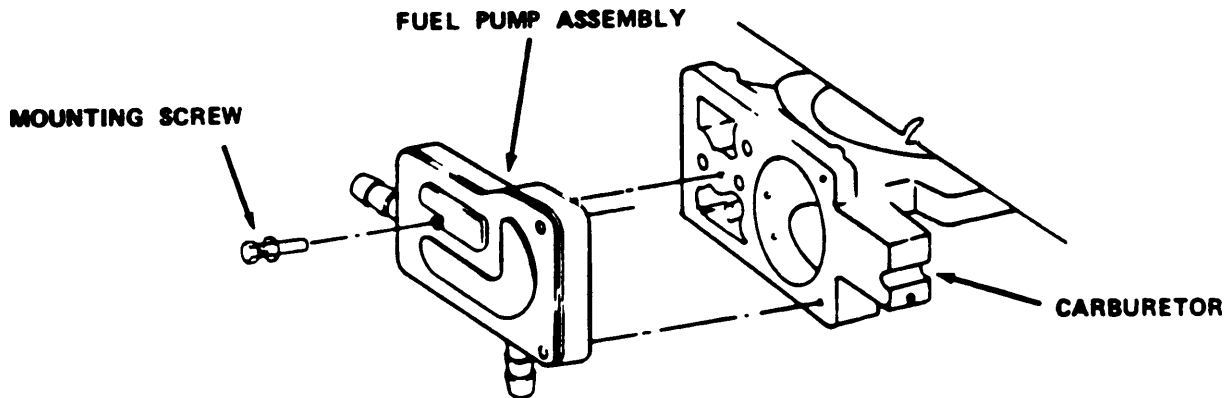

a. Disassembly

Remove three fuel pump mounting screws. Remove fuel pump assembly from carburetor.

5-3. CARBURETOR REPAIR (CONT)

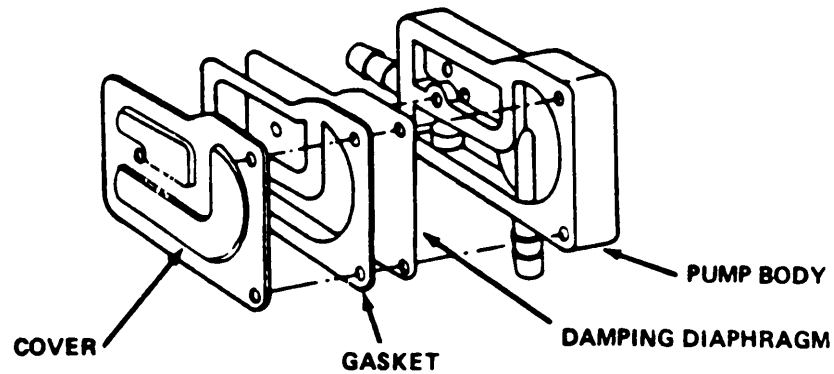

To prevent damage to damping diaphragm, be very careful when separating it from pump body.

- 2 Carefully separate damping diaphragm from pump body. Separate cover, gasket, and damping diaphragm. Discard gasket.

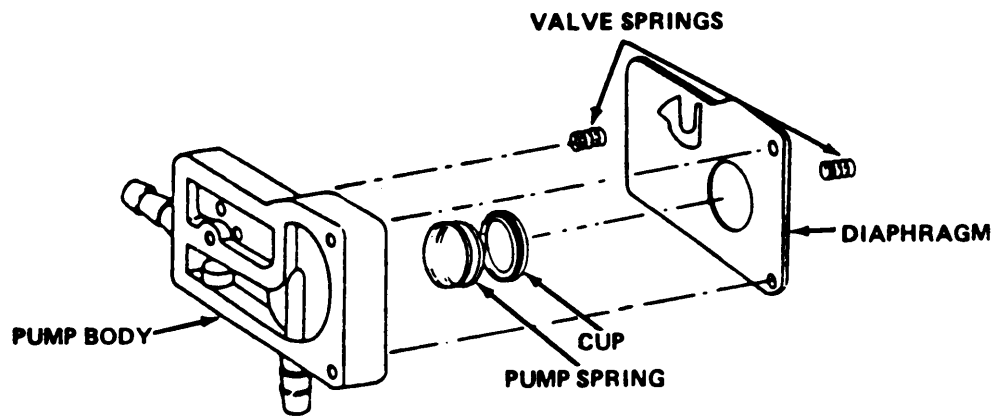

- 3 Separate diaphragm from pump body. Inspect diaphragm for punctures, wrinkles, and wear. Discard if damaged.
- 4 Inspect valve springs, pump spring, and cup for damage or distortion. Discard if damaged or distorted.

5-3. CARBURETOR REPAIR (CONT)

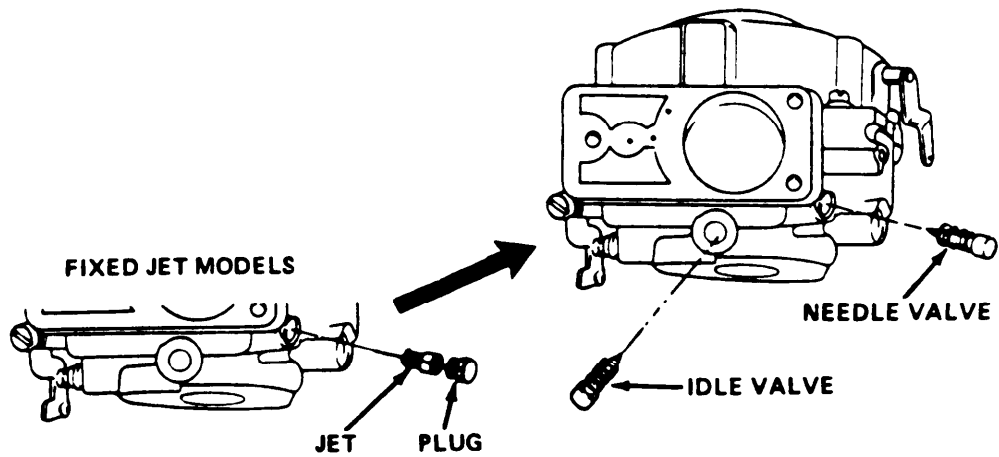

- 5 Remove idle valve.
- 6 For models with needle valve, remove needle valve For models with fixed jet, remove plug and jet.

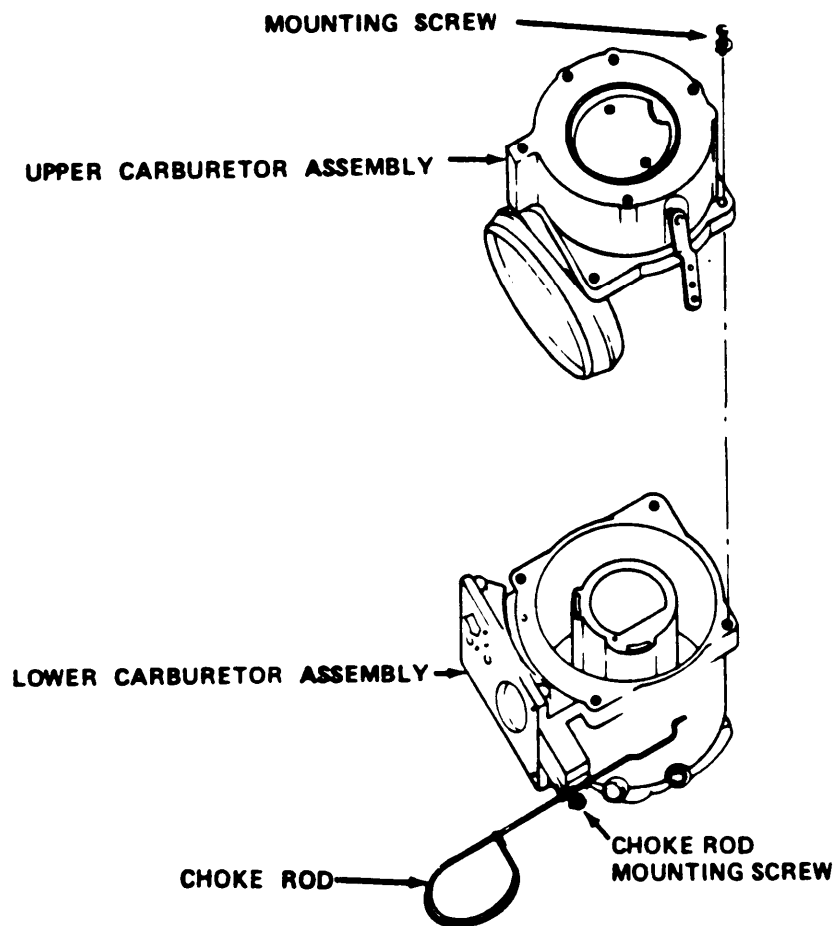

5-3. CARBURETOR REPAIR (CONT)

WARNING

Carburetor may contain some fuel. To prevent possible fire or explosion, DO NOT bring sparks or open flame near carburetor.

- 7 Remove choke rod mounting screw and spring. Remove choke rod from choke shaft. Note hole from which rod is removed
- 8 Remove four upper carburetor assembly mounting screws. Remove upper carburetor assembly from lower carburetor assembly.

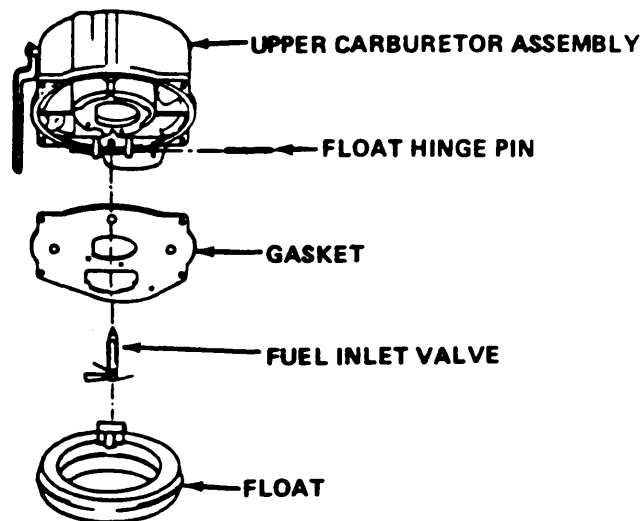

- 9 Turn upper carburetor assembly upside down.
- 10 Remove float hinge pin. Remove float with fuel inlet valve.
- 11 Remove fuel inlet valve from float.
- 12 Remove gasket from upper carburetor assembly.

5-3. CARBURETOR REPAIR (CONT)

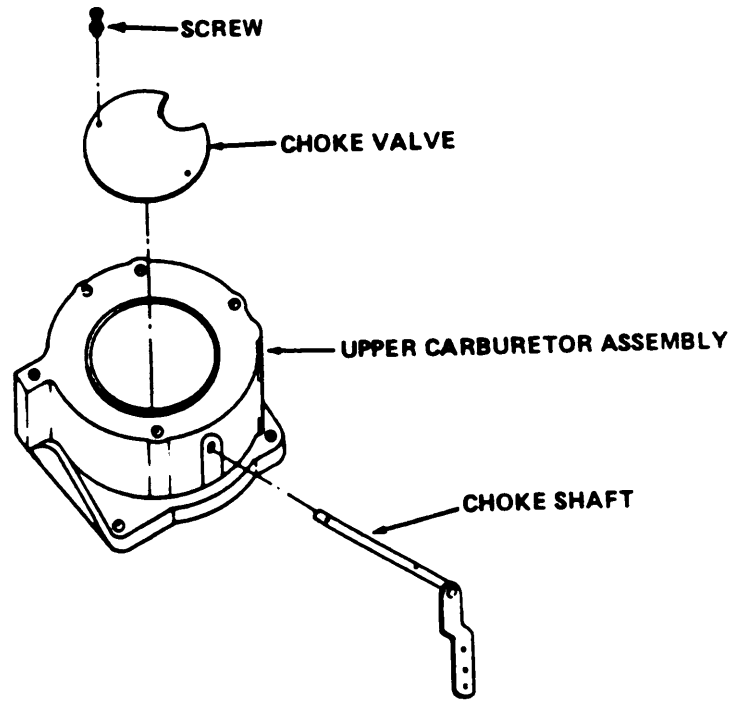

- 13 Remove two screws from choke valve. Remove choke valve from upper carburetor assembly and side choke shaft out.

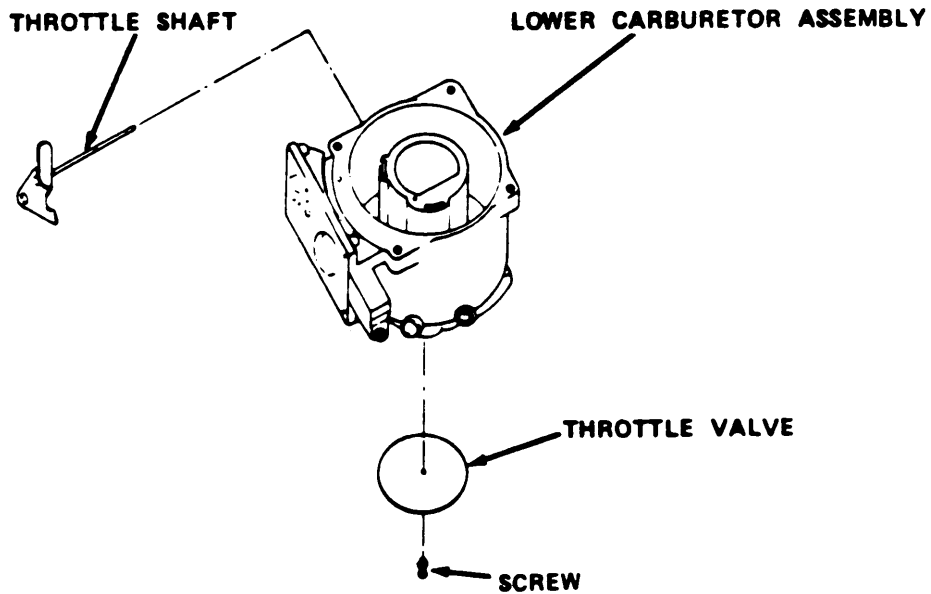

- 14 Remove screw from throttle valve. Remove throttle valve from lower carburetor assembly and slide throttle shaft out.

5-3. CARBURETOR REPAIR (CONT)**b. Servicing****WARNING**

- Solvent may cause toxic fumes. To prevent personal injury, work only in well ventilated area. DO NOT breathe fumes for a long time.
- Solvent is flammable. To prevent from or explosion, DO NOT bring open flame or sparks near solvent.

CAUTION

To prevent damage to rubber seals, foam seals, and nylon parts, DO NOT expose them to solvent.

- 1 Clean all metal carburetor parts using solvent (item 21, appendix E).
- 2 Inspect all parts for wear and damage.

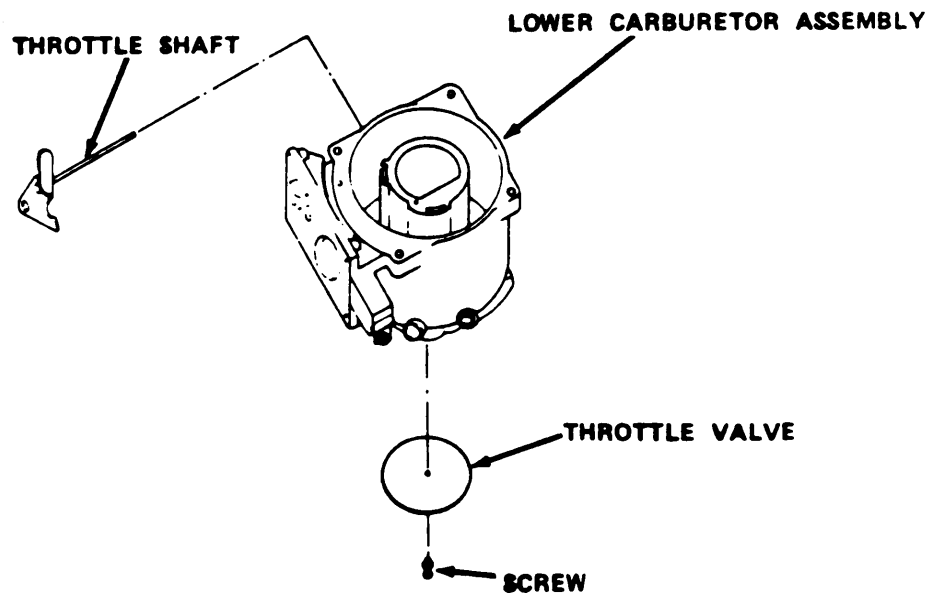
**c. Assembly**

- 1 Slide throttle shaft into place on lower carburetor assembly. Insert throttle valve in shaft and align screw holes. Install screw on shaft and valve.

5-3. CARBURETOR REPAIR (CONT)

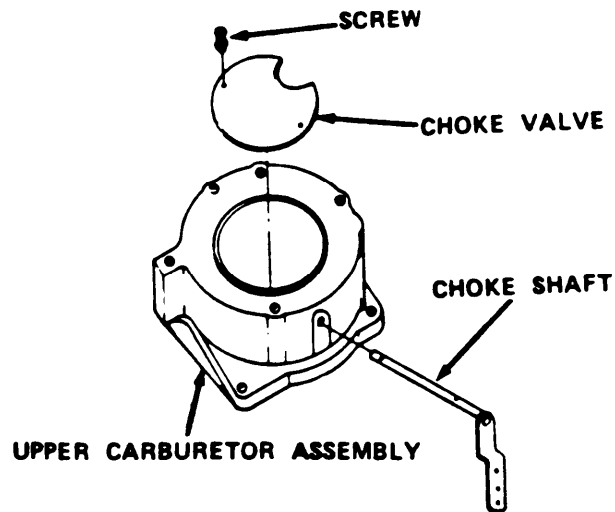

- 2 Slide choke shaft into place on upper carburetor assembly. Place choke valve on shaft and align screw holes. Install two screws on shaft and valve.

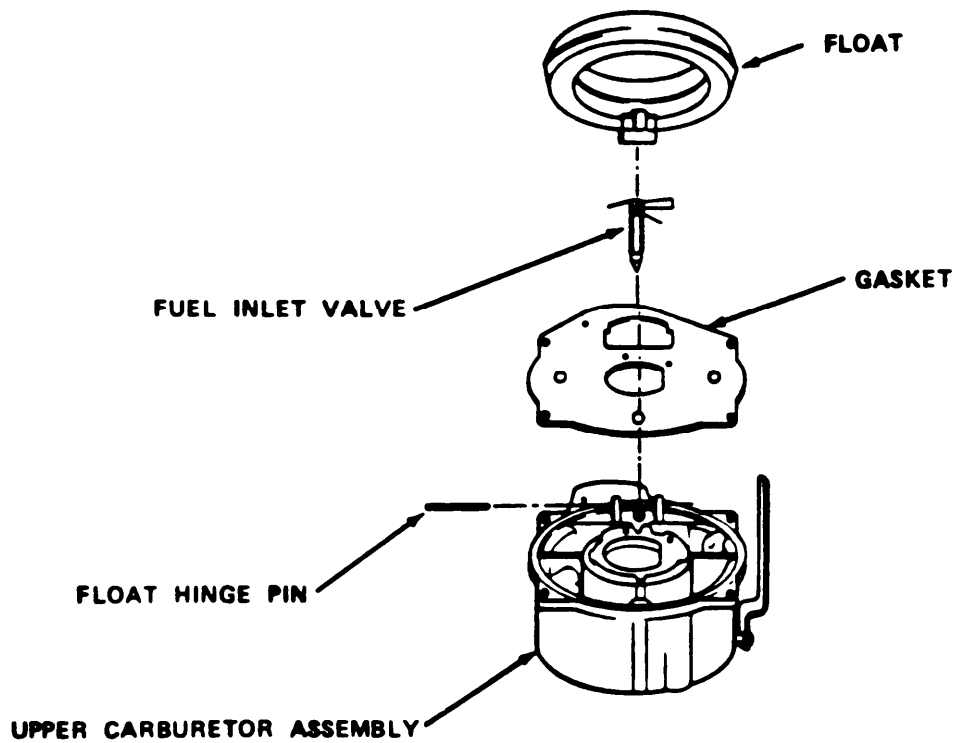

- 3 Install new gasket on upper carburetor assembly.
- 4 Install fuel inlet valve on float.

5-3. CARBURETOR REPAIR (CONT)

- 5 Install float Install float hinge pin.

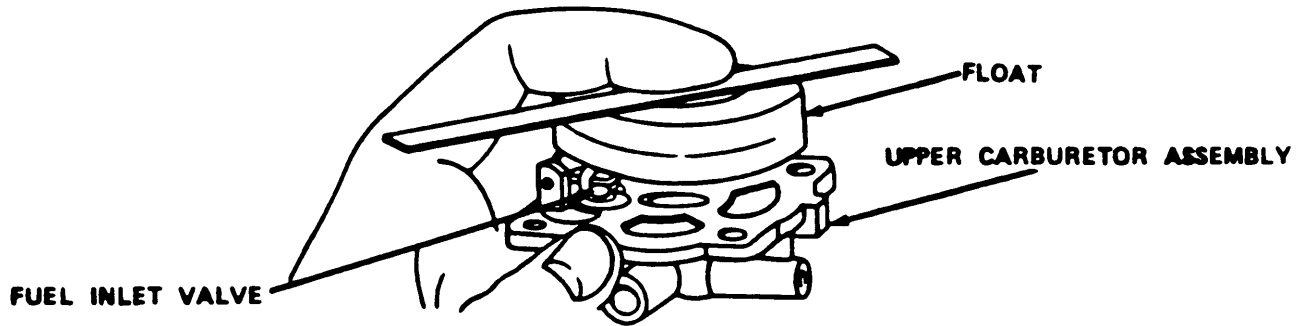

NOTE

Make sure fuel inlet valve is in seat on upper carburetor assembly.

- 6 Check that float is parallel to upper carburetor assembly. If it is not parallel, adjust float level.

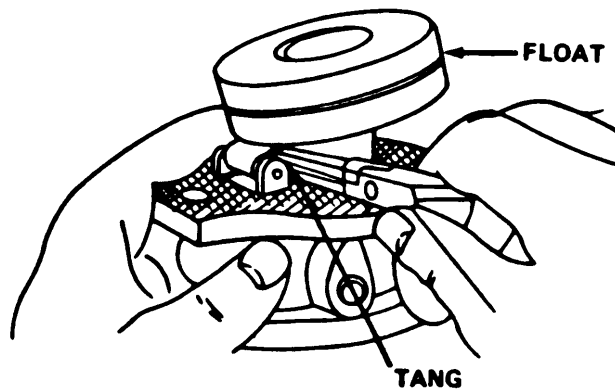

CAUTION

To prevent damage to float, DO NOT press down on float to adjust float level.

- 7 Adjust float level as needed by bending tang.

5-3. CARBURETOR REPAIR (CONT)

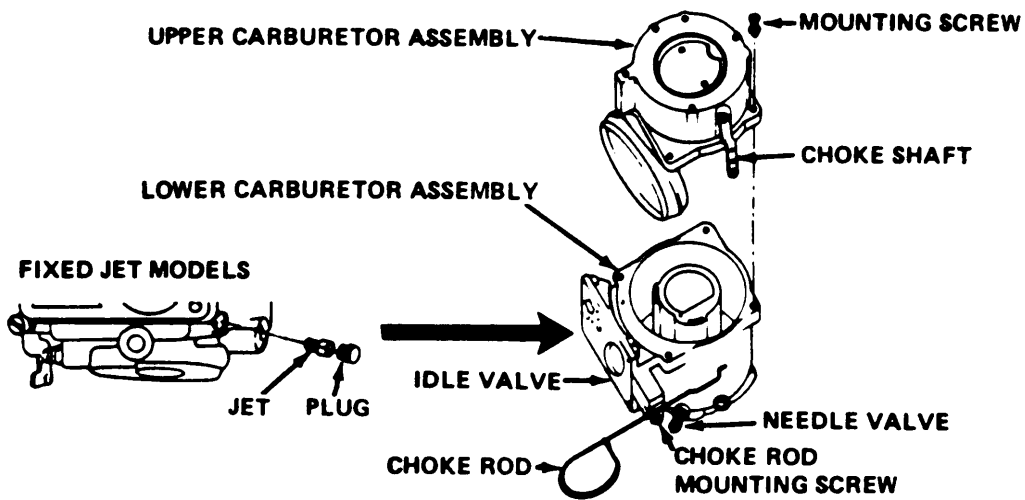

- 8 Install upper carburetor assembly on lower carburetor assembly. Install four upper carburetor assembly mounting screws.
- 9 Install choke rod in correct hole in choke shaft. Install choke rod mounting screw and spring.
- 10 Install idle valve.
- 11 For models with needle valve, install needle valve. For models with fixed jet, install jet and plug.

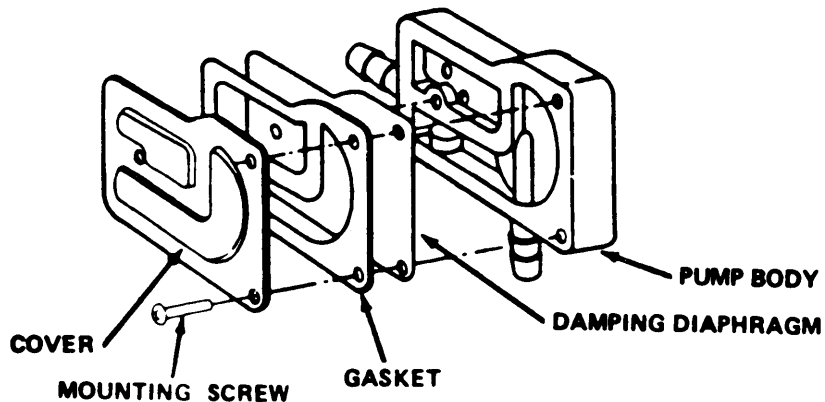

- 12 Assemble cover, gasket, and damping diaphragm. Install on pump body. Insert three mounting screws.

5-3. CARBURETOR REPAIR (CONT)

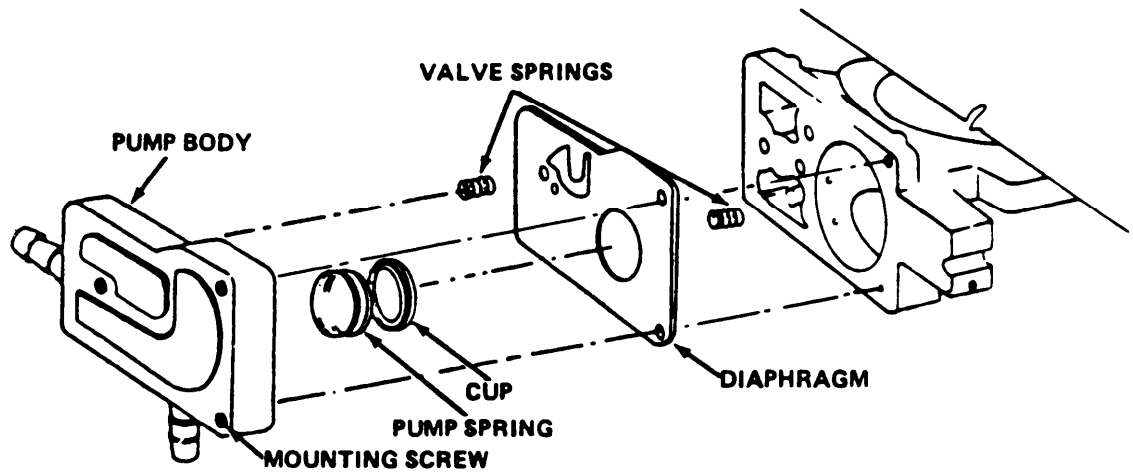

- 13 Place two valve springs, diaphragm, cup, pump spring, and pump body on carburetor. Tighten three mounting screws in staggered sequence.
- 14 Install carburetor on manifold assembly (para 4-21).
- 15 Install air cleaner elements on carburetor (para 4-20).

5 4. STARTER REPAIR

This task covers:

- a. Disassembly
- b. Assembly

INITIAL SETUP

Equipment

Condition

<u>Para</u>	<u>Condition Description</u>	<u>Tools</u>
5-2	Engine stopped, power disconnected, fuel line disconnected, muffler and housing removed.	Common No. 1 Organizational Maintenance Automotive Maintenance and Repair Shop Equipment, item 2, appendix B
4-27	Starter removed.	Master Mechanic's Tool Kit, item 4, appendix B

Materials/Parts

Engine oil, item 10, appendix E

Sandpaper, item 12, appendix E

5-4. STARTER REPAIR (CONT)

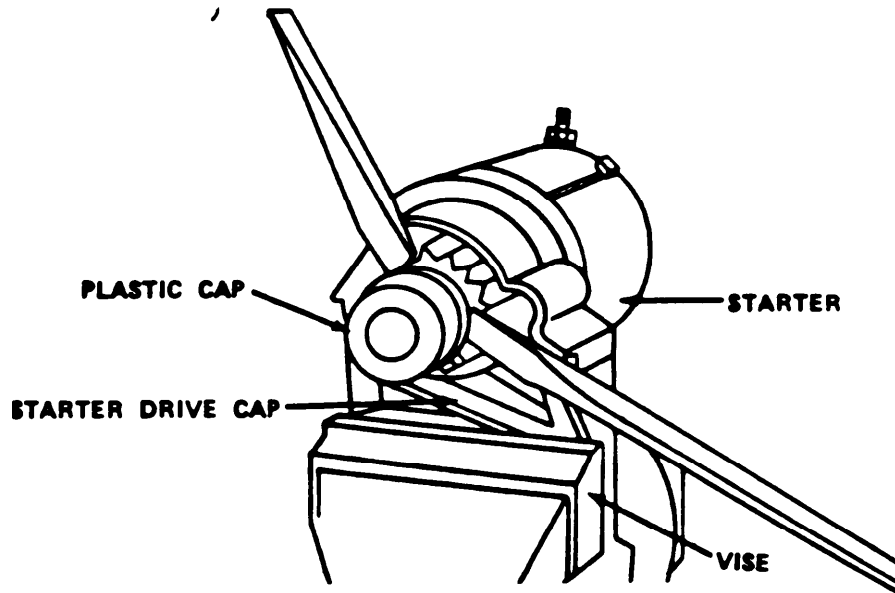

a. Disassembly

CAUTION

To prevent damage to starter, DO NOT clamp motor shell in a vise or strike with hammer.

- 1 Clamp starter drive cap in a vise.
- 2 Pry plastic cap from starter.

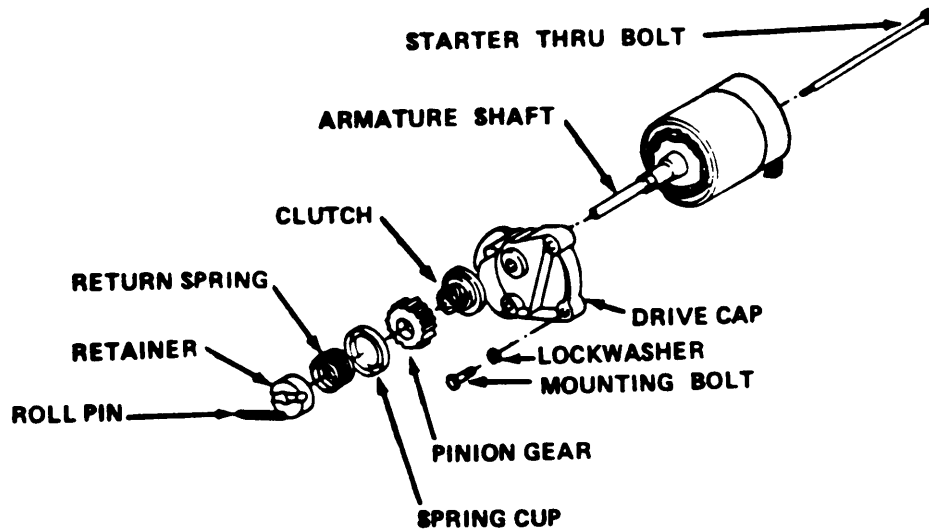

- 3 Drive roll pin from armature shaft.
- 4 Pry off retainer. Remove return spring.

5-4. **STARTER REPAIR (CONT)**

- 5 Pry off spring cup, pinion gear, and clutch. Remove from vise.
- 6 Remove two drive cap mounting bolts and lockwashers. Remove drive cap.
- 7 Remove two starter thru bolts.

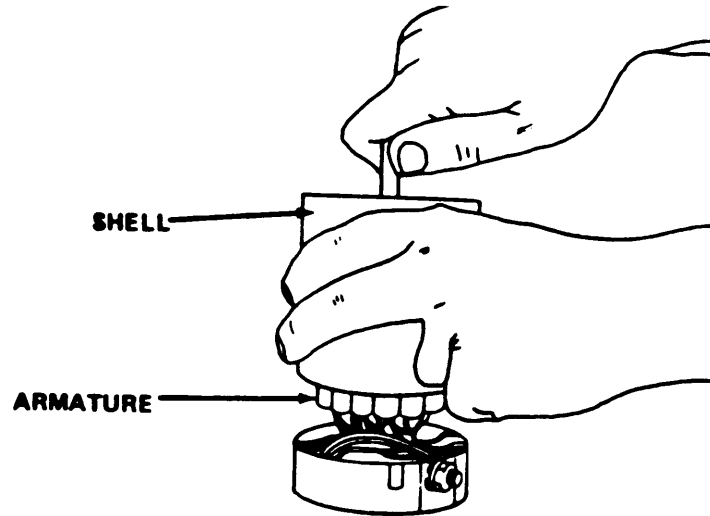

- 8 Hold armature down and slide shell up and off.

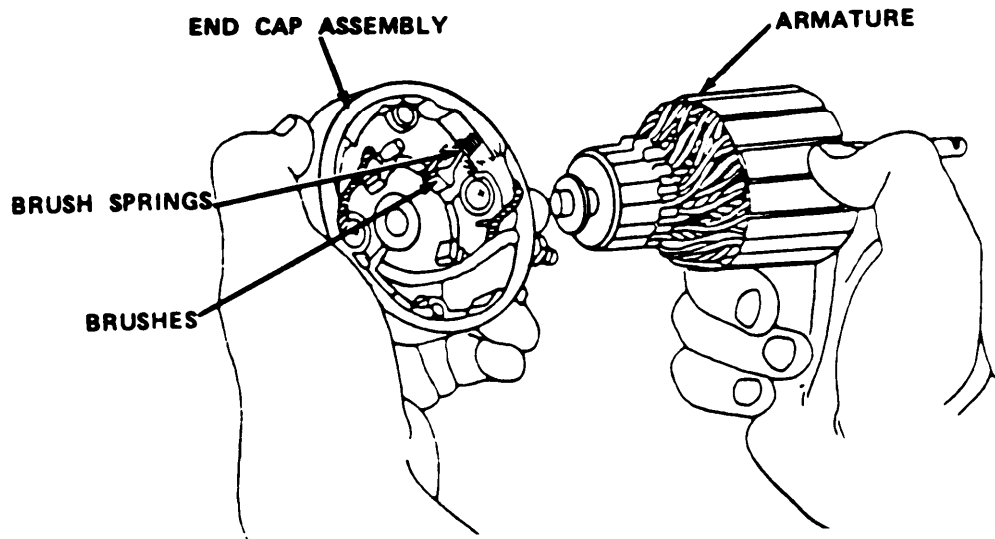

- 9 Remove end cap assembly from armature.

5-4. STARTER REPAIR (CONT)

CAUTION

- To prevent internal damage to parts, DO NOT soak armature, end cap, or housing assembly in cleaning solvent or cleaning solution.
- To prevent fast brush wear, DO NOT use emery cloth in place of sandpaper.

10 Using fine sandpaper, clean all dirt and corrosion from armature, end cap, and shell assembly.

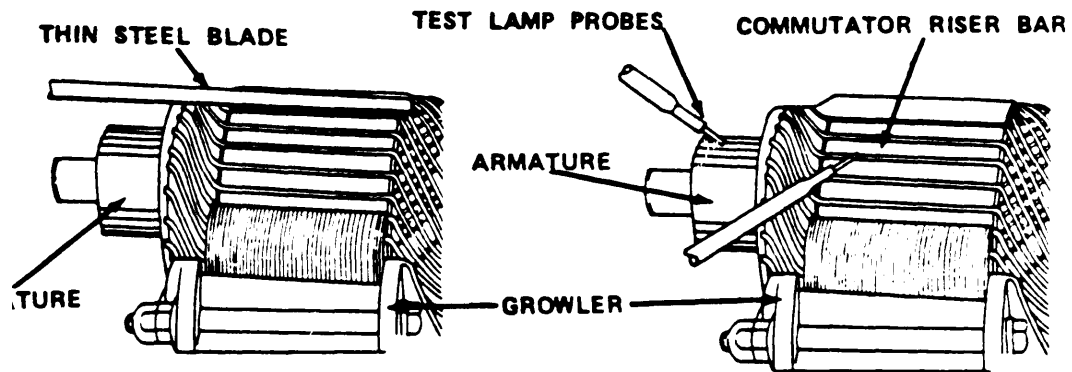

- 11 Place armature in growler and hold a thin steel blade parallel to the core and just above it. Slowly rotate armature in growler. If blade vibrates and is attracted to core, replace armature.
- 12 Connect test lamp probes to armature and each commutator riser bar. If test lights come on, armature is grounded and needs to be replaced.
- 13 Inspect end cap assembly for cracks, breaks in brush wires, and loose brush wire-mounting screws.

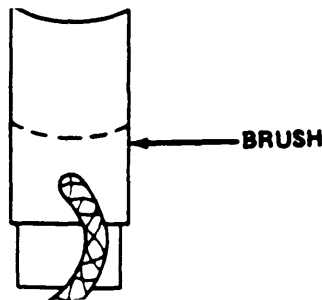

- 14 Measure brush length. If brushes are 1/8 in. (1/3 cm) or less in length, replace them.

5-4. STARTER REPAIR (CONT)

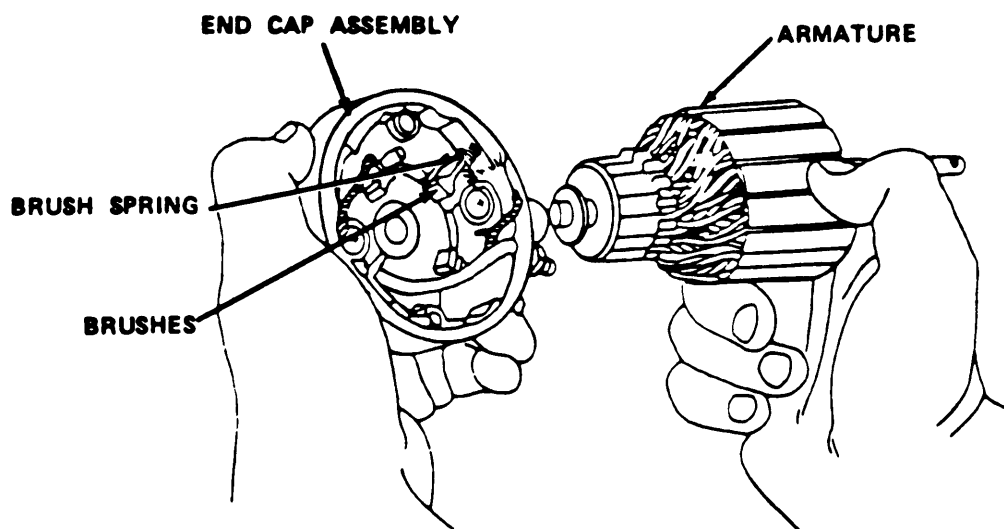

b. Assembly

- 1 Install brush springs and brushes in end cap assembly.
- 2 Using engine oil (MIL-L-46152), lubricate end cap bearing.
- 3 Install armature in end cap assembly.

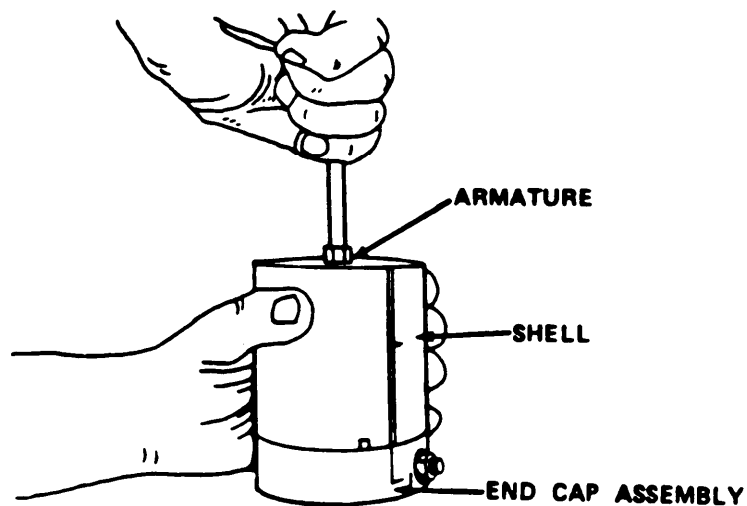

- 4 Hold armature down and slide motor shell on. Aline marks on shell and end cap assembly.

5-4. STARTER REPAIR (CONT)

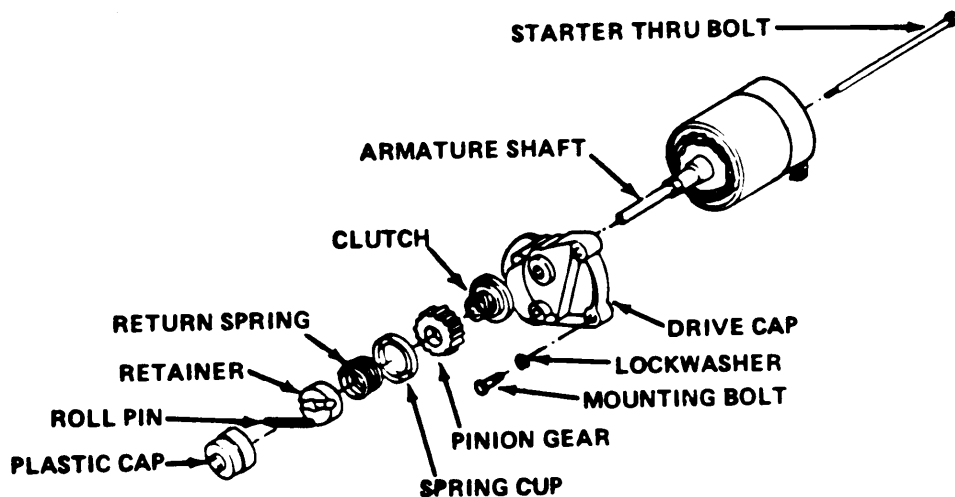

- 5 Install drive cap over end of armature.
- 6 Install and hand-tighten starter motor thru bolts.
- 7 Torque thru bolts to 45 to 55 in. lb (5.1 to 6.2 Nm).
- 8 Install two drive cap mounting bolts and two lockwashers.
- 9 Install clutch and pinion gear with beveled edge of gear away from starter.
- 10 Install spring cup.
- 11 Install return spring.
- 12 Install retainer.
- 13 Install roll pin to armature shaft.
- 14 Install plastic cap on starter assembly. Cap should lock in position when properly assembled.
- 15 Install starter (para 4-27).

5-5. CYLINDER HEADS REPLACEMENT

This task covers:

a. Removal

b. Installation

INITIAL SETUP

Equipment

Condition

<u>Para</u>	<u>Condition Description</u>	<u>Tools</u>
5-2	Engine stopped, power disconnected, fuel line disconnected, muffler and housing removed.	Master Mechanic's Tool Kit, item 4, appendix B
4-23	Starter panel assembly removed.	Sealing compound, item 18, appendix E

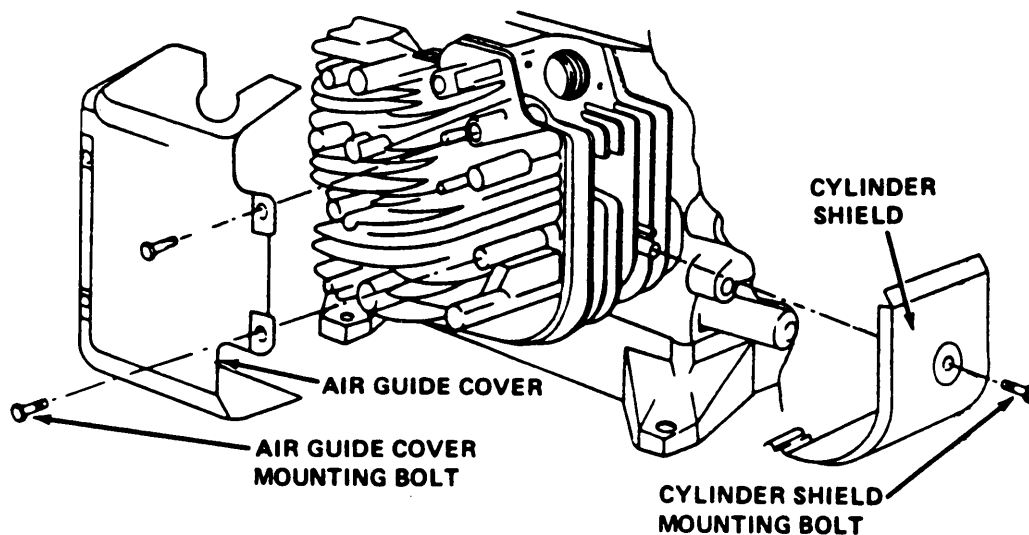

a. Removal of Right Cylinder

- 1 Remove two back air guide cover mounting bolts. Remove cylinder shield mounting bolt. Remove air guide cover and cylinder shield.
- 2 Remove spark plug (para 4-24).

5-5. CYLINDER HEADS REPLACEMENT (CONT)

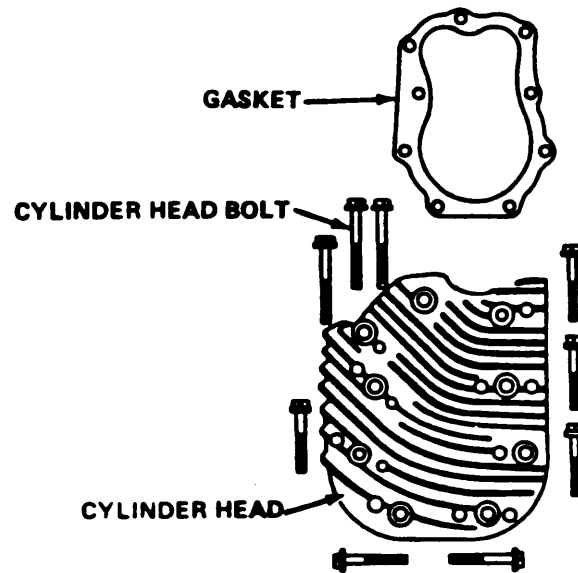

CAUTION

Cylinder head bolts are of two different lengths. To prevent damage to engine during reinstallation, note position of different length bolts. Long bolts are used in exhaust valve area

- 3 Remove nine cylinder head bolts. Remove cylinder head.
- 4 Remove all head gasket material from cylinder head and engine.
- 5 Remove all carbon or foreign material from cylinder head and engine, being careful not to scratch surface.
- 1 Place new cylinder head gasket on cylinder head assembly.
- 2 Place new cylinder head assembly on engine.
- 3 Apply sealing compound (MIL-S-22473) to bolt threads. Install nine cylinder head bolts and hand-tighten.

5-5. CYLINDER HEADS REPLACEMENT (CONT)

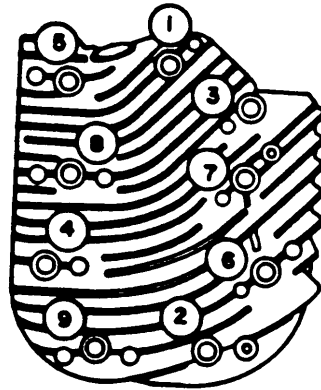

- 4 Torque cylinder head bolts to 160 in. lb (18.1 Nm) following torque pattern above.

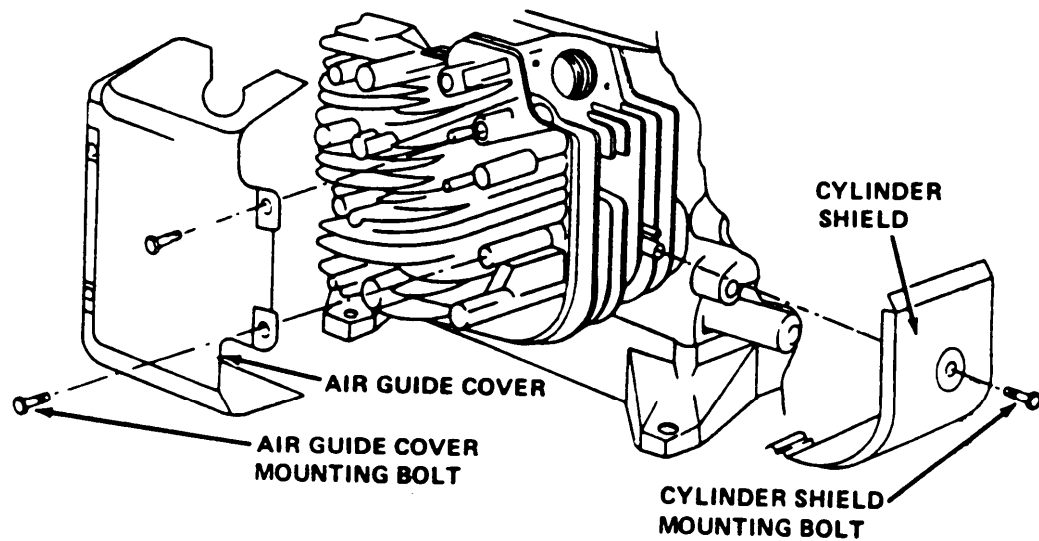

- 5 Install air guide cover and cylinder shield. Install two back air guide cover mounting bolts and cylinder shield mounting bolt.
- 6 Install starter panel assembly (para 4-23).
- 7 Install spark plug (para 4-24).

5-5. CYLINDER HEADS REPLACEMENT (CONT)

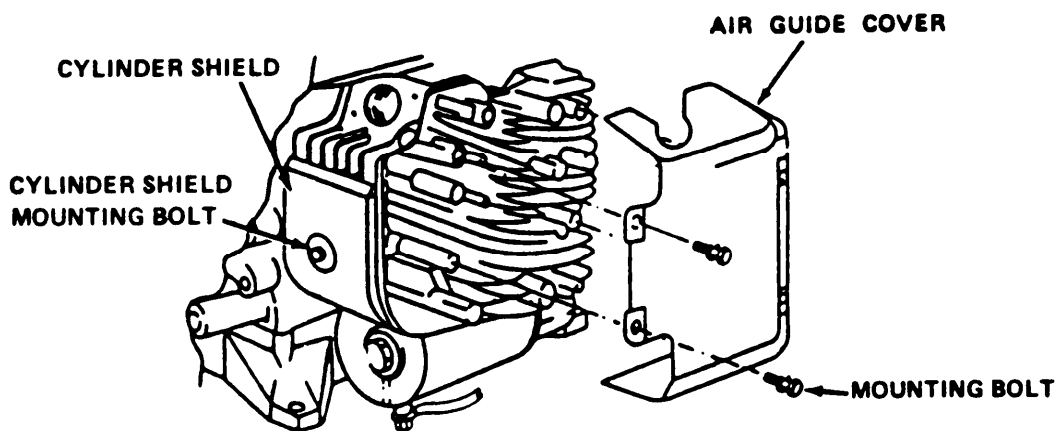

c. Removal of Left Cylinder Head

- 1 Remove four air guide cover mounting bolts. Remove cylinder shield mounting bolt. Remove air guide cover and cylinder shield.
- 2 Remove spark plug (para 4-24).

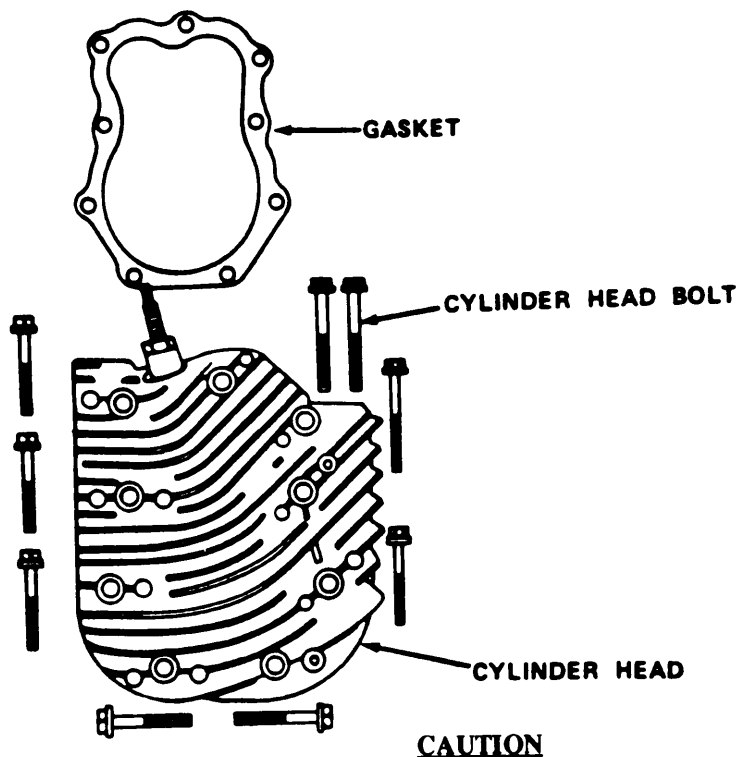

Cylinder head bolts are of two different lengths. To prevent damage to engine during reinstallation, note position of different length bolts. Long bolts are used in exhaust valve area.

5-5. CYLINDER HEADS REPLACEMENT (CONT)

- 3 Remove nine cylinder head bolts, Remove cylinder head.
- 4 Remove all head gasket material from cylinder head and engine.
- 5 Remove all carbon or foreign material from cylinder head and engine, being careful not to scratch surface.

d. Installation of Left Cylinder Head

- 1 Place new cylinder head gasket on cylinder head assembly.
- 2 Place new cylinder head assembly on engine.
- 3 Apply sealing compound (MIL-S-22473) to bolt threads. Install nine cylinder head bolts and hand-tighten.

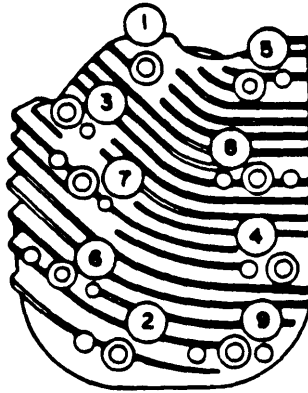

- 4 Torque cylinder head bolts to 160 in. lb (18.1 Nm) following torque pattern above.
- 5 Install air guide cover and cylinder shield. Install four air guide cover mounting bolts and cylinder shield mounting bolt.
- 6 Install spark plug (para 4-24).

5-6. CYLINDER BLOCK ASSEMBLY REPLACEMENT

This task covers:

- a. Removal
- b. Installation

5-6. CYLINDER BLOCK ASSEMBLY REPLACEMENT (CONT)

INITIAL SETUP

Tools

Master Mechanic's Tool Kit, item 4, appendix B

Personnel Required

Two to lift engine.

Equipment Condition

Equipment Condition

<u>Para</u>	<u>Condition Description</u>	<u>Para</u>	<u>Condition Description</u>
5-2	Engine stopped, power disconnected, fuel line disconnected, muffler and housing removed.	4-21	Carburetor removed.
4-19	Engine assembly removed.	4-22	Intake manifold assembly removed.
4-15	Fan assembly removed.	5-5	Cylinder head assemblies removed.
4-16	Pulley drive assembly removed (applicable to water chillers Model LCW-2685 only)	4-27	Starter removed.
4-17	Centrifugal clutch removed (applicable to water chillers, Model LCC-2685 only)	4-25	Armature group removed.
4-26	Dipstick and tube assembly removed.	4-28	Flywheel and ring gear assembly removed.
		4-18	Exhaust system removed.

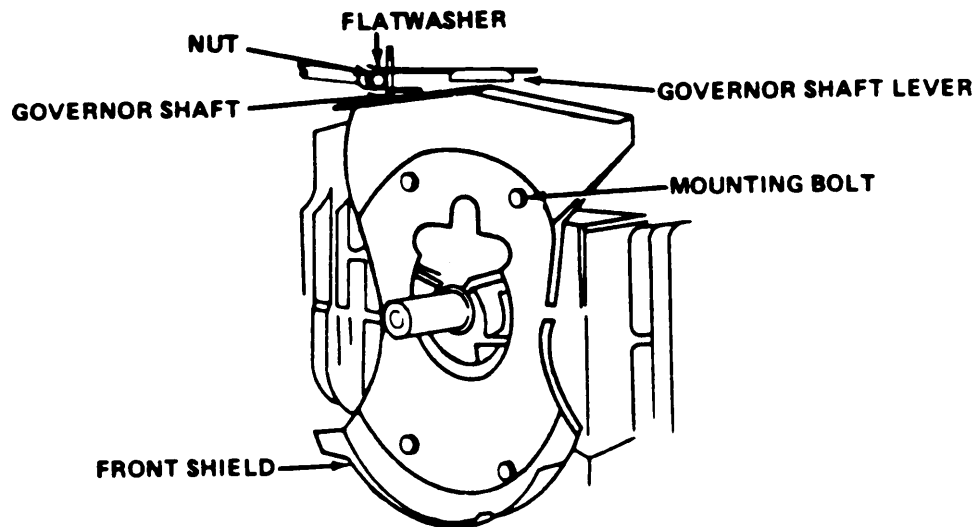

a. Removal

- 1 Remove governor shaft lever nut and flatwasher.

5-6. CYLINDER BLOCK ASSEMBLY REPLACEMENT (CONT)

- 2 Remove governor shaft lever.
- 3 Remove four front shield mounting bolts. Remove front shield

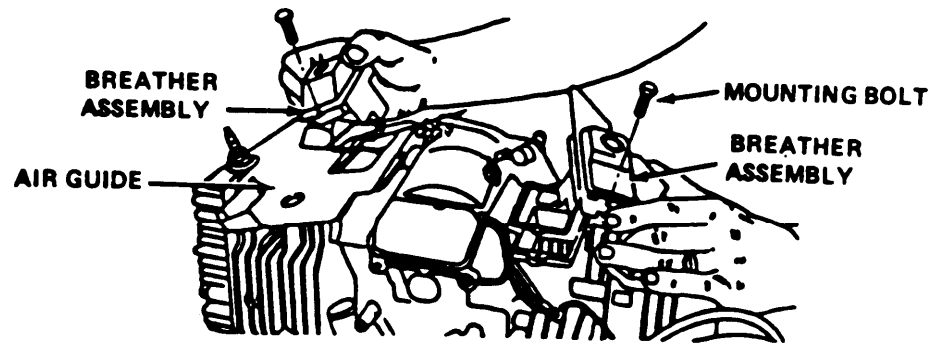

- 4 Remove two breather assembly mounting bolts from right cylinder. Remove breather assembly and air guide.
- 5 Remove two breather assembly mounting bolts from left cylinder. Remove breather assembly and air guide.

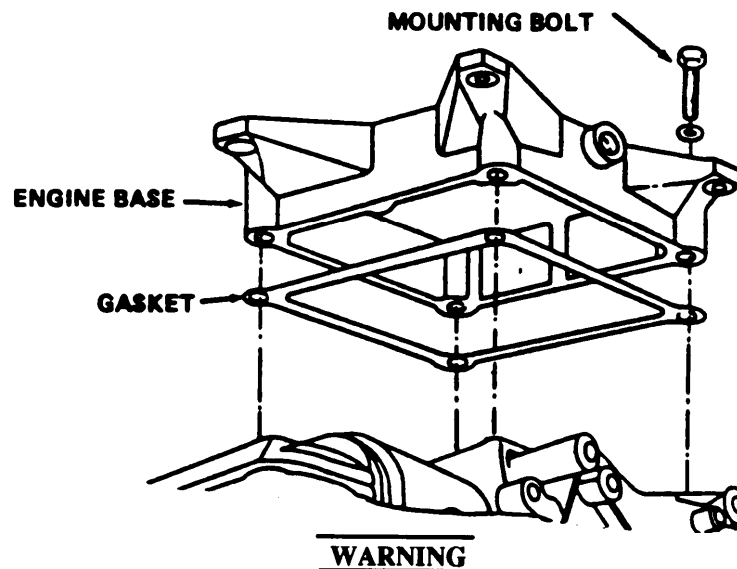

Due to weight of equipment two persons required for next step to prevent injury and damage to equipment.

- 6 Turn engine assembly upside down.

5-6. CYLINDER BLOCK ASSEMBLY REPLACEMENT (CONT)

- 7 Remove four engine base mounting bolts and four flatwashers. Remove engine base. Remove gasket.

b. Installation

- 1 Install engine base and gasket on cylinder block assembly. Reinstall four engine base mounting bolts and four flatwashers.

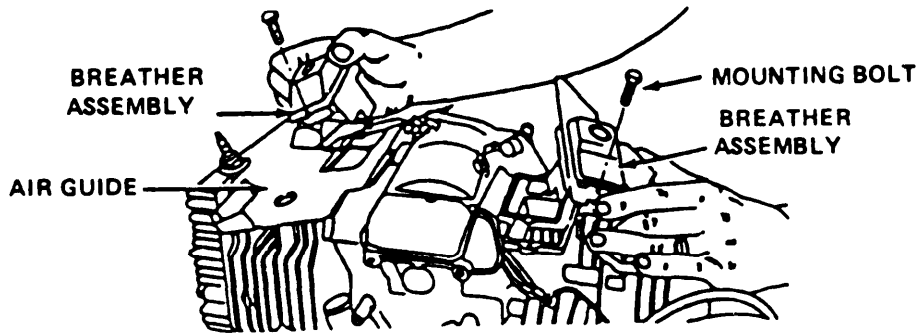

WARNING

Due to weight of equipment two persons required for next step to prevent injury and damage to equipment.

- 2 Turn engine assembly rightside up.
- 3 Install breather assembly and air guide on right cylinder. Install two breather assembly mounting bolts.
- 4 Install breather assembly and air guide on left cylinder. Install two breather assembly mounting bolts.

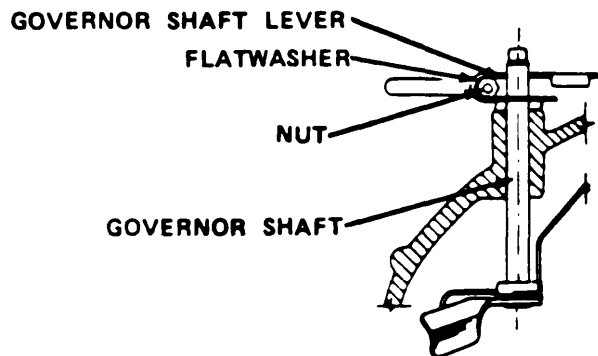

- 5 Install governor shaft lever. Rotate lever left as far as it will go. Hold lever in this position and rotate governor shaft left as far as it will go.

5-6. CYLINDER BLOCK ASSEMBLY REPLACEMENT (CONT)

- 6 Install governor shaft lever nut and flatwasher. Torque locknut to 100 in.lb (11.3 Nm).
- 7 Install front shield. Install four front shield mounting bolts.
- 8 Install exhaust manifold assembly (pm 4-18).
- 9 Install flywheel and ring gear assembly (para 4-28). DO NOT install blower housing.
- 10 Install armature group (para 4-25). DO NOT install blower housing.
- 11 Install starter (para 4-27).
- 12 Install cylinder head assemblies (para 5-5).
- 13 Install intake manifold assembly (para 4-22).
- 14 Install carburetor assembly (para 4-21).
- 15 Install dipstick and tube assembly (para 4-26).
- 16 Install pulley drive assembly (applicable to water chillers, Model LCW-2685) (para 4-16).
- 16.1 Install centrifugal clutch (applicable to water chillers, Model LCC-2685 only) (para 4-17).
- 17 Install fan assembly (para 4-15).
- 18 Install engine assembly (para 4-19).

5-7. REFRIGERATION SYSTEM LEAK-TEST

This task covers:

- a. General Instructions
- b. Electronic Gas Detector Method
- c. Soap Solution Method

INITIAL SETUP

Equipment

Condition

<u>Para</u>	<u>Condition Description</u>	<u>Tools</u>
5-2	Engine stopped power disconnected, fuel line disconnected, muffler and housing removed.	Refrigeration Unit Semite Tool KiL item 5, appendix B

5-7. REFRIGERATION SYSTEM LEAK-TEST (CONT)

Materials/Parts

Liquid detergent, item 6,
appendix E

R-12 Refrigerant, item 15,
appendix E

a. General Instructions. After repair or replacement of any refrigeration system component, the system must be thoroughly leak-tested before it is recharged with refrigerant. Leak-testing is also a method of troubleshooting when a system has lost all or part of its refrigerant charge. There are two methods of leak-testing: the electronic gas detector method and the soap solution method.

b. Electronic Gas Detector Method. The electronic gas detector is sensitive to a small amount of gas, making it able to detect small leaks. However, due to rapid dispersion of gas, it may be hard to pinpoint large leaks. The detector must be used in a well-ventilated but draft-free area.

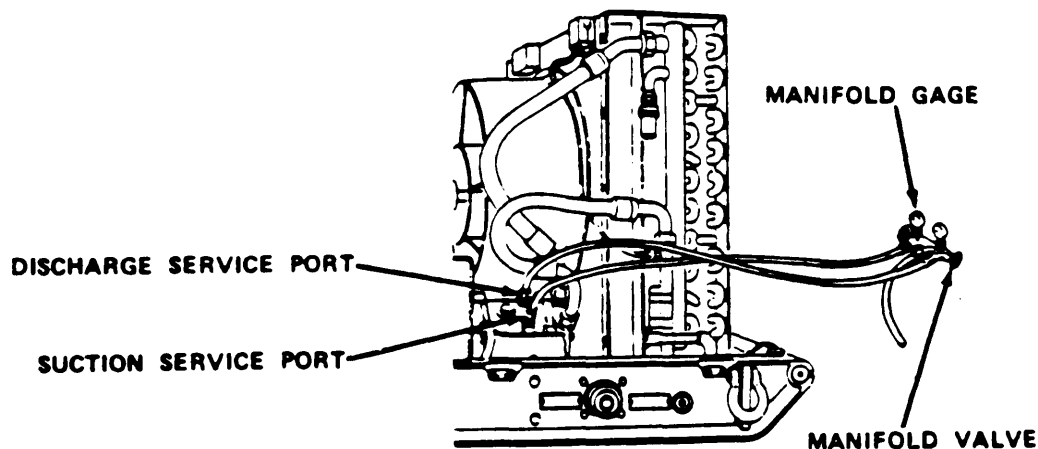

- 1 Remove caps from two compressor service ports.
- 2 Close manifold valves.

NOTE

- DO NOT tighten hose connections.
- Hose on compound gage side of manifold is suction hose.
- Hose on high pressure gage side of manifold is discharge hose.

5-7. REFRIGERATION SYSTEM LEAK-TEST (CONT)

3 Connect manifold discharge hose to D (discharge) service port.

4 Connect manifold suction hose to S (suction) service port.

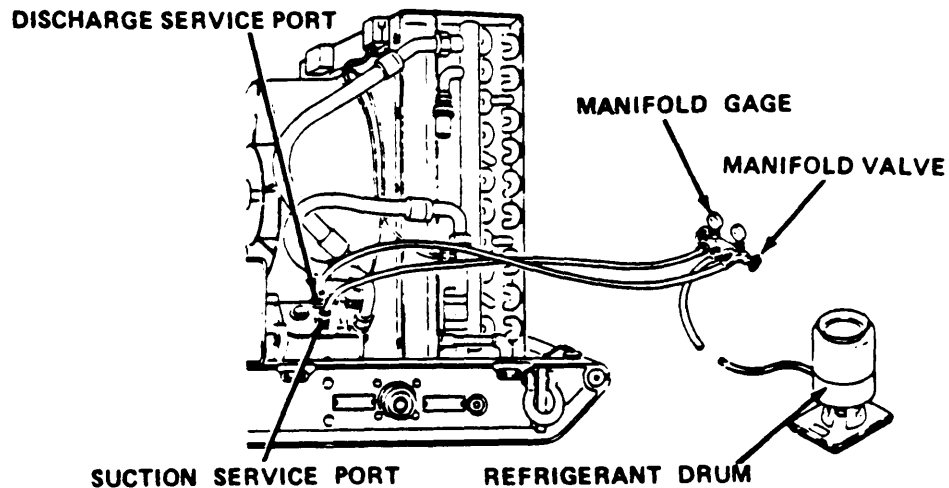
**WARNING**

- Liquid refrigerant under pressure may cause injury to skin or eyes. Wear thermal protective gloves and goggles where skin or eye contact is possible.
- Contact of refrigerant with hot surface or flame creates toxic gas. Keep open flame and hot surfaces away from refrigerant.

5 Connect refrigerant drum to center hose connection of charging manifold. Open drum valve.

6 Partially open manifold valves. Allow gas to escape at service ports to purge service lines.

7 After two or three seconds, tighten service port hose connections.

8 Allow gas to flow into system. Gages should show equal pressure.

9 Turn on leak detector and hold probe near refrigeration system.

5-7. REFRIGERATION SYSTEM LEAK-TEST (CONT)

10 Move probe slowly over entire system. If any leaks are present, it will make a beeping sound. The nearer to a leak the probe is held, the more rapid the beeps will become.

11 If a leak is found, discharge system (aram 5-9). Tighten fitting or replace defective component as needed.

12 If no leaks are found, evacuate and charge refrigeration system (para 5-9).

c. Soap Solution Method. In this method, liquid detergent mixed with water is brushed onto possible leak points. Bubbles will form in the solution where gas is escaping.

1 Pressurize system with refrigerant gas (subpara b, steps 1 thru 8).

2 Dilute liquid soap with small amount of water.

3 Using small brush, coat system with soap solution.

4 If leak is present, bubbles will appear in soap solution.

5 Rinse off soap solution with clear water after test is complete.

6 If leak was found, discharge system (para 5-9). Tighten fitting or replace defective component as needed.

7 If no leaks were found, evacuate and charge refrigeration system (para 5-9).

5-8. REFRIGERATION SYSTEM PRESSURE TEST

This task covers testing only.

INITIAL SETUP

Equipment

Condition

Para

Condition Description

Tools

5-2

Engine stopped, power disconnected, fuel line disconnected, muffler and housing removed.

Refrigeration Service Unit Tool Kit, item 5, appendix B

5-8. REFRIGERATION SYSTEM PRESSURE TEST (CONT)

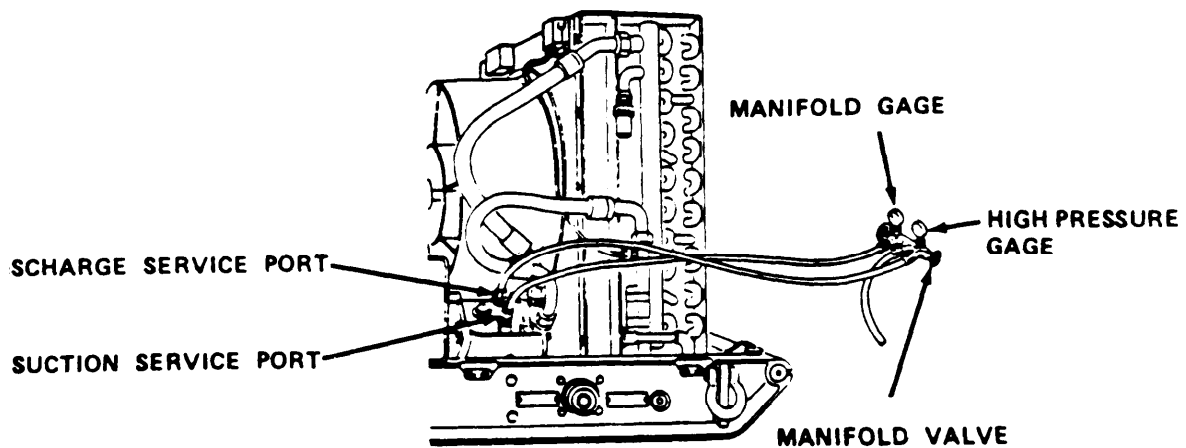
**NOTE**

If testing pressure to check high or low pressure switch, engine must be off for at least 30 minutes before restarting.

- 1 Remove caps from two compressor service ports.
- 2 Close two manifold valves.

NOTE

Hose on compound gage side of manifold is suction hose. Hose on high pressure gage side of manifold is discharge hose.

- 3 Connect manifold discharge hose to D (discharge) service port.
- 4 Connect manifold suction hose to S (suction) service port.
- 5 Open manifold valves.
- 6 Start engine and run for at least 10 minutes while observing gages.
- 7 High pressure gage should show less than 295 psi (2034 kPa) and low pressure gage should show more than 35 psi (241 kPa).
- 8 If high pressure gage shows more than 295 psi (2034 kPa) check condenser for blockage, or refrigeration line or hose for bend or kink.

5-8. REFRIGERATION SYSTEM PRESSURE TEST (CONT)

9 If low pressure gage shows less than 35 psi (240 kpa), service refrigeration system (para 5-9).

5-9. REFRIGERATION SYSTEM SERVICE

This task covers:

- a. Discharging
- b. Evacuation
- c. Charging

INITIAL SETUP

Equipment

Condition

Para

Condition Description

Tools

5-2

Engine stopped, power disconnected, fuel line disconnected, muffler and housing removed.

Refrigeration Unit Service Tool Kit, item 5, appendix B

Vacuum pump, item 7, appendix B
Recovery and recycling Unit, item 10, appendix B

Materials/Parts

R-12 refrigerant, item 15, appendix E

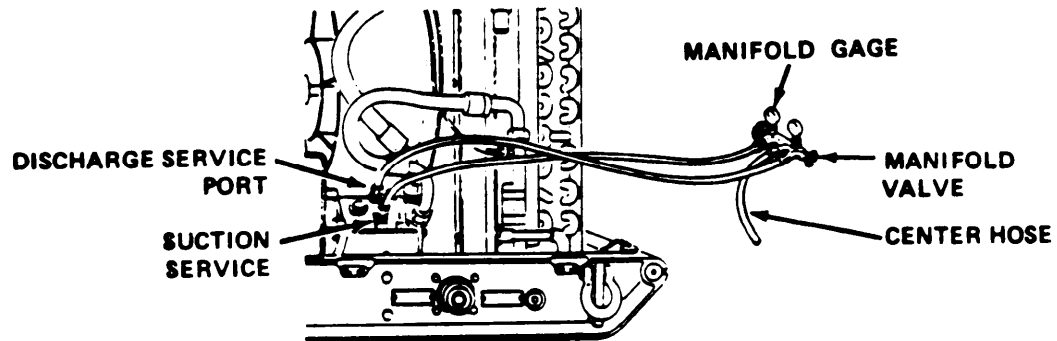

- a. Discharging

NOTE

- Hose on compound gage side of manifold is suction hose.
- Hose on high pressure gage side of manifold is discharge hose.

1 Remove caps from two service ports on compressor.

5-9. REFRIGERATION SYSTEM SERVICE (CONT)

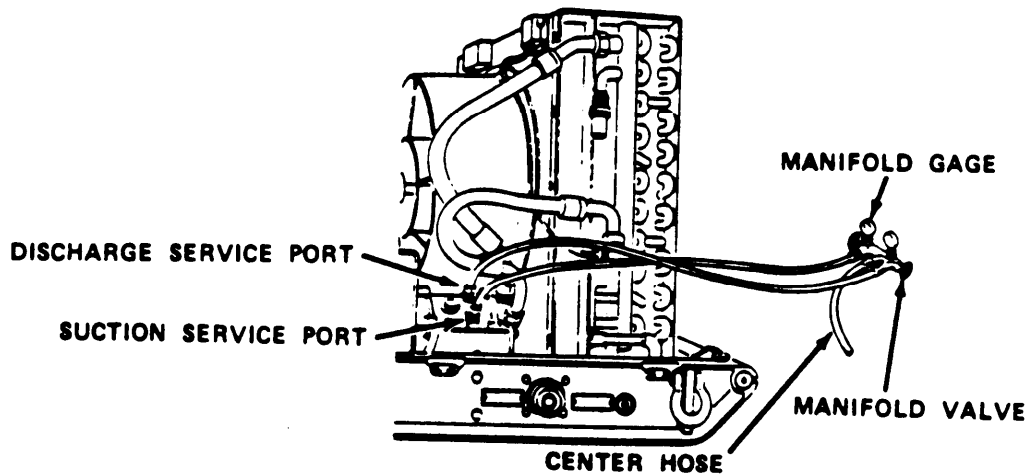

- 2 Close two manifold valves.
- 3 Connect manifold discharge hose to D (discharge) service port.
- 4 Connect manifold suction hose to S (suction) service port.
- 5 Connect hose to center section of manifold.

WARNING

- Liquid refrigerant under pressure may cause injury to skin or eyes. Wear thermal protective gloves and goggles when skin or eye contact is possible.
- Contact of refrigerant with hot surface or flame creates toxic gas. Keep open flame and hot surfaces away from refrigerant.

NOTE

- In accordance with Environmental Protection Agency regulations refrigerants cannot be discharged into the atmosphere. A refrigerant recovery and recycling unit must be used whenever discharging the refrigerant system.
- Operation of the recovery/recycling unit must be by AUTHORIZED PERSONNEL ONLY.

5-9. REFRIGERATION SYSTEM SERVICE (CONT)

6 Connect and operate a recovery/recycling unit in accordance with the manufacturer's instructions.

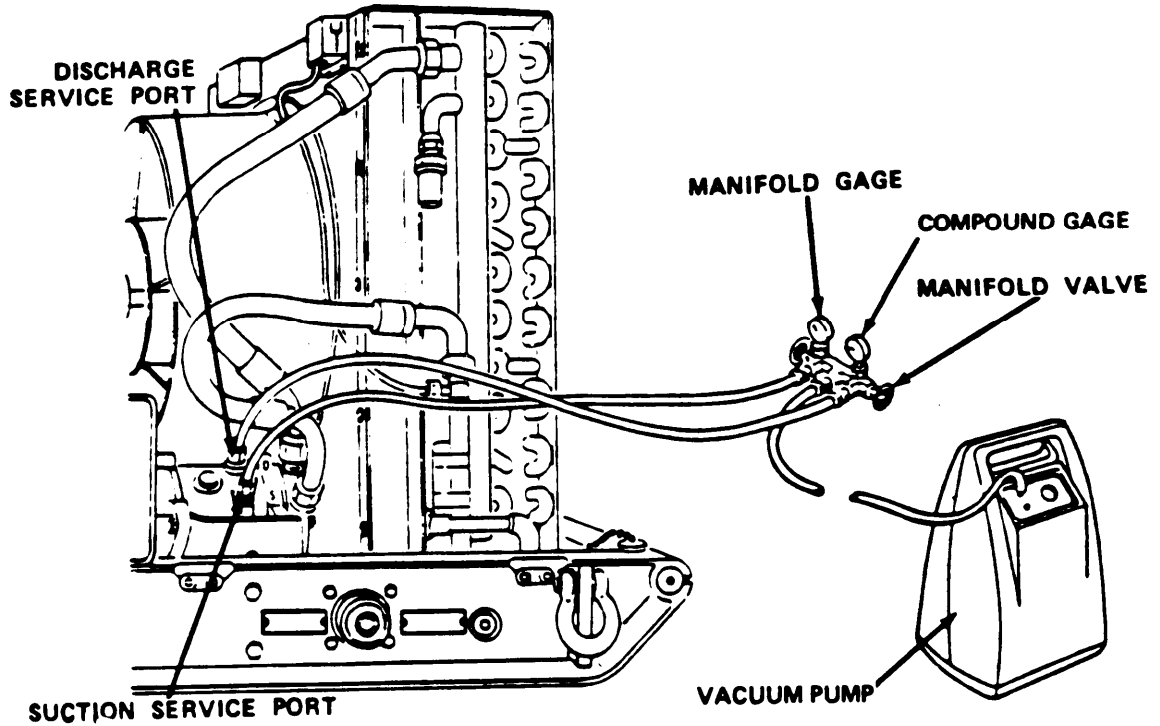

b. Evacuation

CAUTION

Leak-test the system (para 5-7) before evacuating it. DO NOT evacuate a leaking system. The vacuum created can cause air, moisture, and dirt to enter the system.

5-9. REFRIGERATION SYSTEM SERVICE (CONT)**NOTE**

If any refrigeration system components have been removed or replaced, install a new filter-drier before evacuating system (para 5-19).

- 1** Close two manifold service valves.
- 2** Connect hoses from charging manifold to compressor service ports.
- 3** Connect center manifold hose to vacuum pump.
- 4** Start vacuum pump.
- 5** Open charging manifold valves.

NOTE

If gage does not reach 29 in. (74 cm) of mercury, there may be a leak or too much moisture in the system or a problem with the vacuum pump. Leak-test the system (para 5-7).

- 6** Run vacuum pump until gage measures at least 29 in. (74 cm) of mercury.
- 7** Run vacuum pump for about one hour while watching manifold gage. Shut off pump and look at compound gage. Any loss of vacuum over a 15-minute period indicates leakage. If this happens, leak-test the system (para 5-7).
- 8** Close charging manifold valves.
- 9** Disconnect pump from center hose connection.

5-9. REFRIGERATION SYSTEM SERVICE (CONT)

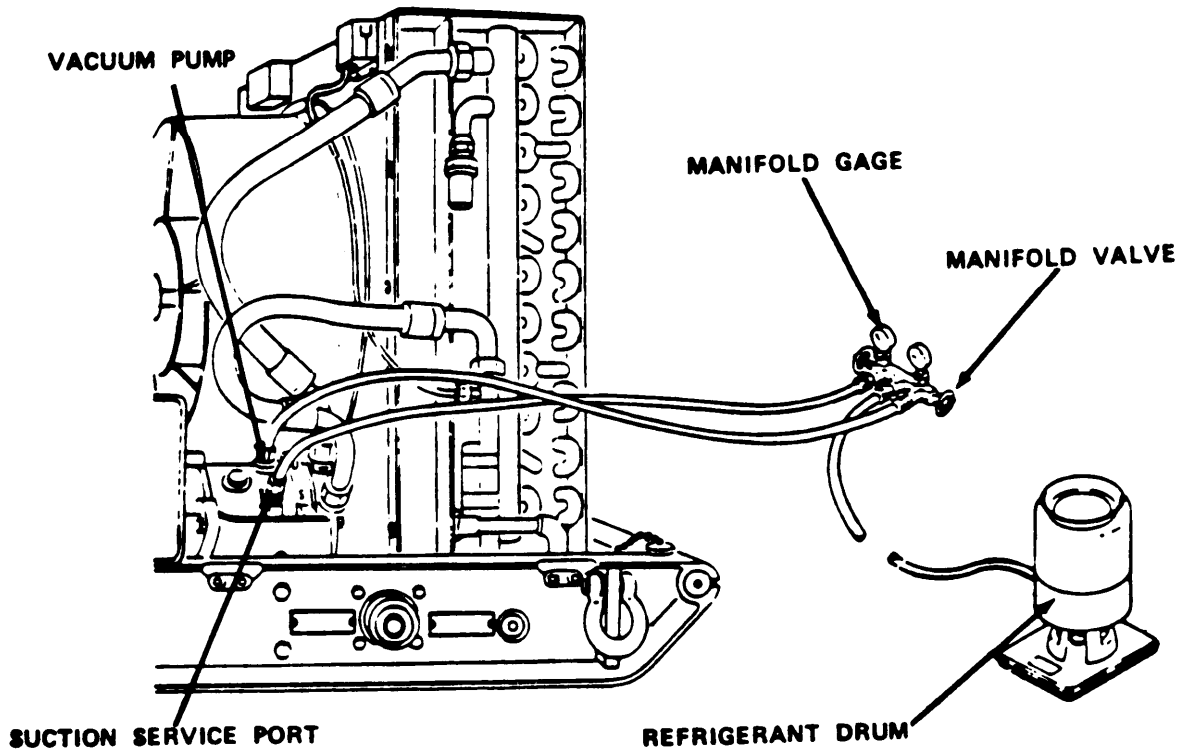

c. Charging

CAUTION

- Evacuate system before charging to prevent to prevent moisture buildup. This prevents freezing in the system.
- Charge the system with reftigerant before operation.

1 Remove caps from two compressor service ports.

2 Close manifold valves.

NOTE

DO NOT tighten hose connections.

3 Connect manifold discharge hose to D (discharge) service port.

4 Connect manifold suction hose to S (suction) service port.

5-9. REFRIGERATION SYSTEM SERVICE (CONT)**WARNING**

- Liquid refrigerant under pressure may cause injury to skin or eyes. Wear thermal protective gloves and goggles when skin or eye contact is possible.
- Contact of refrigerant with hot surface or flame creates toxic gas. Keep open flame and hot surfaces away from refrigerant.

NOTE

- Whenever available, use recycled refrigerant for charging the refrigeration system.
- 5 Connect refrigerant drum to center hose connection of charging manifold. Open drum valve.
 - 6 Partially open manifold valves. Allow gas to escape at service ports to purge service lines.
 - 7 After 2 or 3 seconds, tighten two service port hose connections.
 - 8 Allow gas to flow into system. Gages should show equal pressure.

CAUTION

To prevent damage to refrigeration system, make sure manifold suction valve is closed.

- 9 Close manifold suction valve.
- 10 Position drum so that liquid can be used for charging. Some drums must be turned upside down; some are equipped with a selector valve.
- 11 Allow liquid refrigerant to flow into system until two manifold gages have stabilized.
- 12 Close drum valve and manifold discharge valve.
- 13 Start water chiller (para 2-6a).
- 14 Position drum for gas only or turn selector valve to gas only position.
- 15 Open drum valve. Open manifold suction valve.

5-9. REFRIGERATION SYSTEM SERVICE (CONT)

- 16 Add refrigerant until charged with 3.75 lb (1.7 kg). If no scales available, charge until REFRIGERANT SIGHT GLASS shows clear refrigerant with no bubbles.
- 17 When system is fully charged, close drum valve and suction valve.
- 18 Run water chiller for 15 minutes. If operation is normal, quickly disconnect hose from S (suction) service port
- 19 Check REFRIGERANT SIGHT GLASS for the following:
 - CLEAR BUBBLE-FREE LIQUID: Shows that system is fully charged and dry.
 - GREEN CENTER: Shows that system is fully charged and has acceptable moisture content.
 - MILKY WHITE OR BUBBLY LIQUID: Shows that system has low charge. Repeat charging procedure.
 - YELLOW CENTER: Shows that there is too much moisture in the system. Discharge system; replace filter-drier (para 5-19);evacuate system; and repeat charging procedure.
- 20 Place toggle switch S3 in STOP position. Disconnect hose from D (discharge) Service port.
- 21 Install protective caps on two compressor service ports.

5-10. COMPRESSOR SUCTION HOSE REPLACEMENT

This task covers:

- a. Removal
- b. Installation

INITIAL SETUP

Equipment
Condition

<u>Para</u>	<u>Condition Description</u>	<u>Tools</u>
5-2	Engine stopped, power disconnected, fuel line disconnected, muffler and housing removed.	Master Mechanic’s Tool Kit, item 4, appendix B

5-10. COMPRESSOR SUCTION HOSE REPLACEMENT (CONT)

Equipment

Condition

<u>Para</u>	<u>Condition Description</u>
5-9	Refrigeration system discharged.

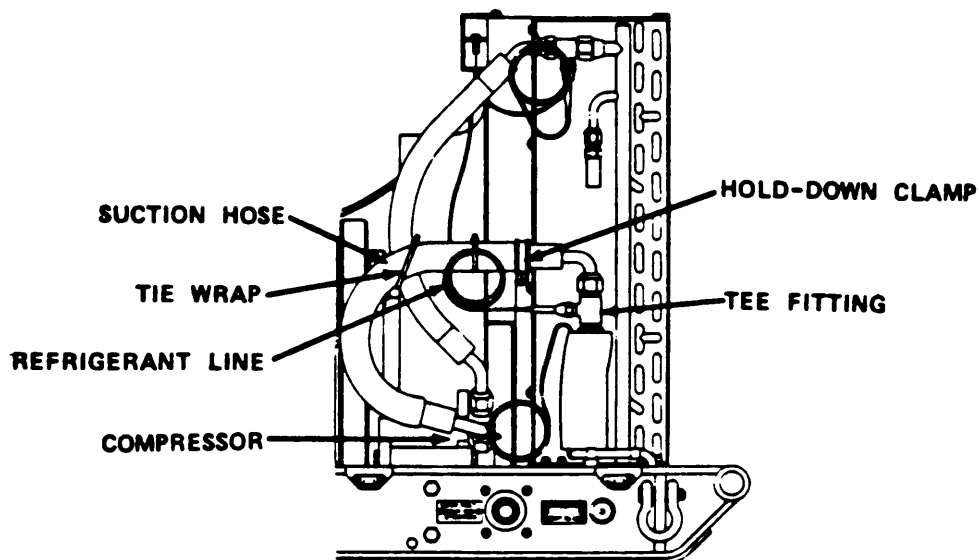
**a. Removal**

- 1 Cut tie wraps from hose.
- 2 Remove screw, lockwasher, and hold-down clamp.
- 3 Remove hose fitting from compressor.
- 4 Remove hose fitting from tee fitting. Remove hose.

b. Installation

- 1 Install hose fitting on tee fitting.
- 2 Install hose fitting on compressor suction port.
- 3 Install screw, lockwasher, and hold-down clamp.
- 4 Move two refrigerant lines back to hose. Install tie wraps around lines and hose.

5-10. COMPRESSOR SUCTION HOSE REPLACEMENT (CONT)

NOTE

If any refrigeration system components have been removed or replaced, install a new filter-drier before evacuating system (para 5-19).

- 5 Leak-test system (para 5-7).
- 6 Evacuate system (para 5-9).
- 7 Charge system (para 5-9).

5-11. COMPRESSOR DISCHARGE HOSE REPLACEMENT

This task covers

- a. Removal
- b. Installation

INITIAL SETUP

Equipment

Condition

Para

Condition Description

Tools

5-2

Engine stopped, power disconnected, fuel line disconnected, muffler and housing removed.

Master Mechanic's Tool Kit, item 4, appendix B

5-9

Refrigeration system discharged.

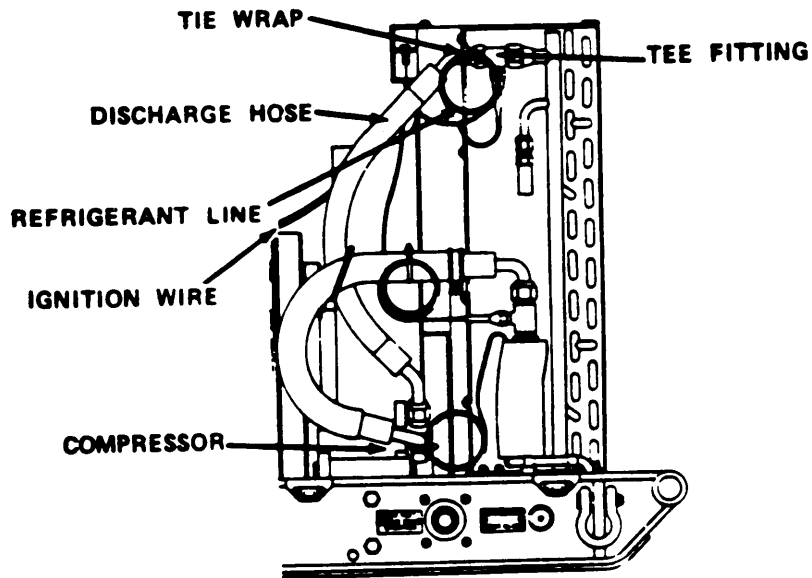

5-11. COMPRESSOR DISCHARGE HOSE REPLACEMENT (CONT)

a. Removal

- 1 Cut tie wrap as needed to free refrigerant line.
- 2 Remove hose fitting from compressor.
- 3 Remove hose fitting from tee fitting.

b. Installation

- 1 Install hose fitting at tee fitting.
- 2 Install hose fitting at compressor discharge service port.
- 3 Move refrigerant line and ignition wire back to hose. Install tie wraps around hose and refrigerant line.

NOTE

If any refrigeration system components have been removed or replaced, install anew filter-drier before evacuating system (para 5-19).

- 4 Leak-test system (para 5-7).
- 5 Evacuate system (para 5-9).
- 6 Charge system (para 5-9).

5-12. HIGH PRESSURE SWITCH REPLACEMENT

This task covers

a. Removal

b. Installation

INITIAL SETUP

Tools

Master Mechanic's Tool Kit,
item 4, appedix B

Materials/Parts

Tags item 22,appendix E

5-12. HIGH PRESSURE SWITCH REPLACEMENT (CONT)

Equipment
Condition

Para	Condition Description
5-2	Engine stoppeD power disconnected, fuel line disconnected, muffler and housing removed.
5-9	Refrigeration system discharged.

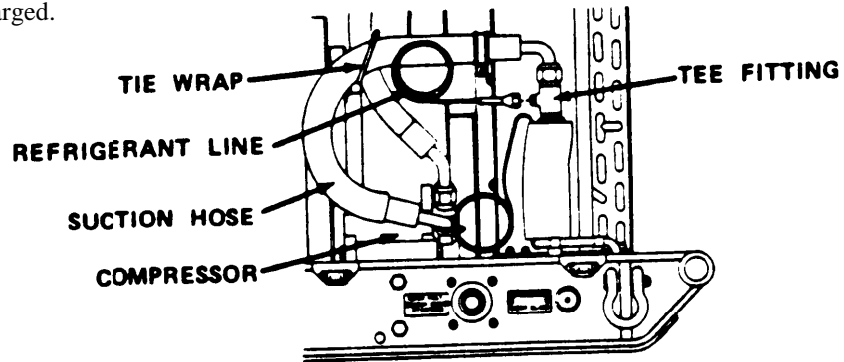

a. Removal

- 1 Cut tie wrap from suction hose of compressor.
- 2 Remove refrigerant line at tee fitting.

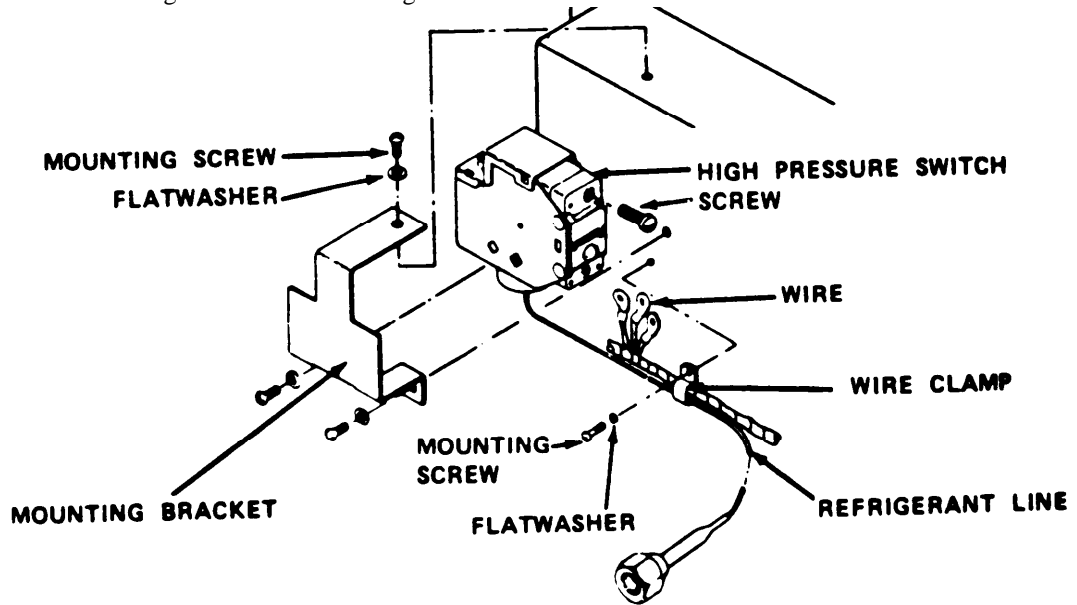

- 3 Remove two screws, two flatwashers, and two wire clamps.

5-12. HIGH PRESSURE SWITCH REPLACEMENT (CONT)

WARNING

To prevent electric shock, make sure power is disconnected from 12/24 VOLT INPUT FOR STARTING connection before performing this procedure.

- 4 Tag three wires from switch. Remove two screws and three wires.
- 5 Remove three bracket mounting screws and three flatwashers.
- 6 Remove mounting bracket from switch.
- 7 Remove high pressure switch and refrigerant line.

b. Installation

- 1 Install high pressure switch and refrigerant line.
- 2 Install mounting bracket three mounting screws, and three flatwashers.
- 3 Connect three wires to switch. Install two screws. Remove tags.
- 4 Install two screws, two flatwashers, and two wire clamps around ignition wire and refrigerant line.

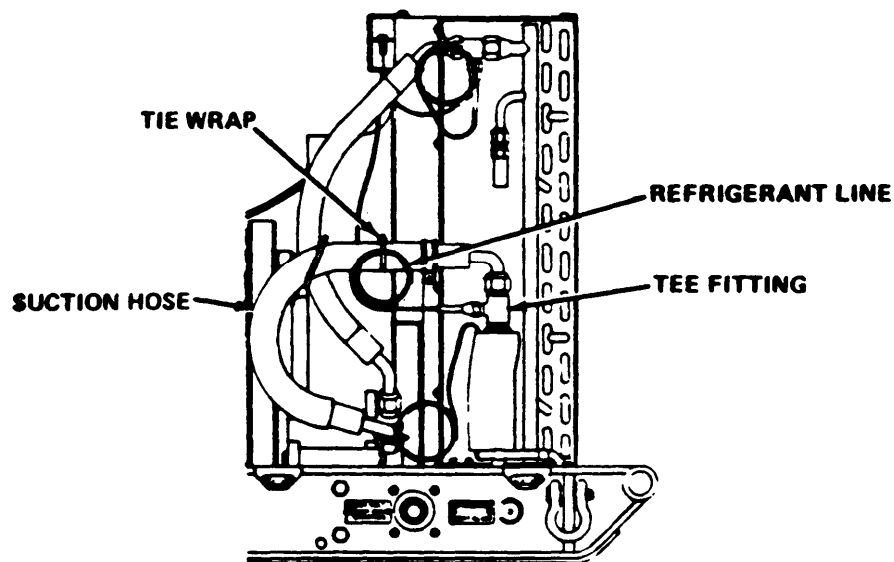

5-12. HIGH PRESSURE SWITCH REPLACEMENT (CONT)

- 5 Install refrigerant line fitting to tee fitting.
- 6 Install tie wrap around refrigerant line and suction hose.

NOTE

If any refrigeration system components have been removed or replaced, install a new filter-drier before evacuating system (para 5-19).

- 7 Leak-test system (para 5-7).
- 8 Evacuate system (para 5-9).
- 9 Charge system (para 5-9).

5-13. LOW PRESSURE SWITCH REPLACEMENT

This task covers:

- a. Removal
- b. Installation

Equipment
Condition

<u>Para</u>	<u>Condition Description</u>	<u>Tools</u>
5-2	Engine stopped, power disconnected, fuel line disconnected, muffler and housing removed.	Master Mechanic's Tool Kit, item 4, appendix B
5-9	Refrigeration system discharged.	

5-13. LOW PRESSURE SWITCH REPLACEMENT (CONT)

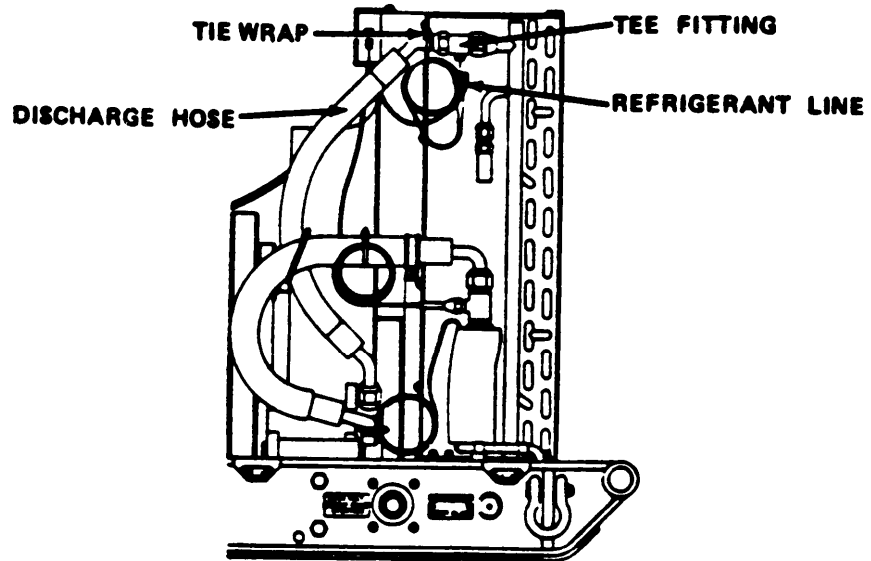

a. Removal

- 1 Cut tie wrap from discharge hose of compressor.
- 2 Remove refrigerant line from tee fitting.

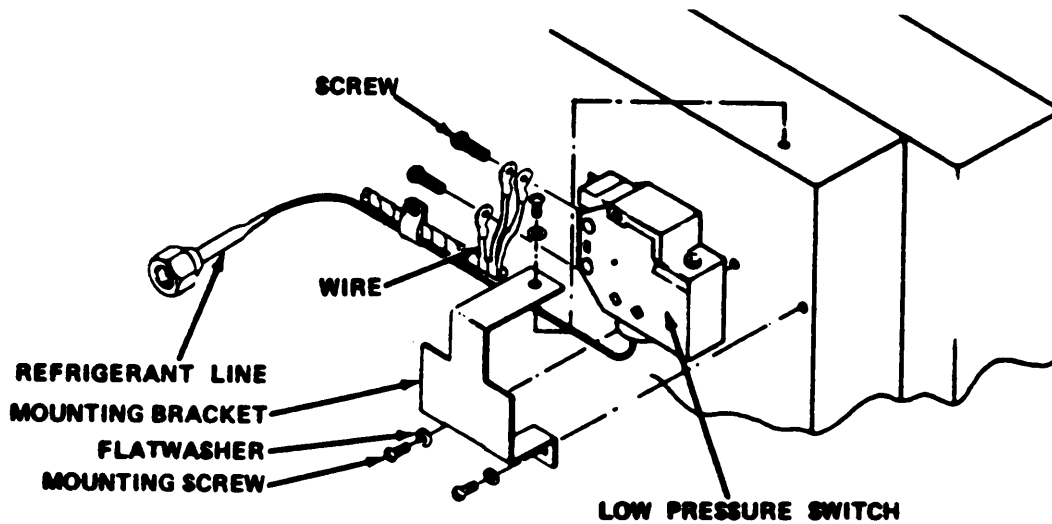

- 3 Tag three wires from switch. Remove two screws and three wires.
- 4 Remove three bracket mounting screws and three flatwashers.

5-13. LOW PRESSURE SWITCH REPLACEMENT (CONT)

- 5 Remove mounting bracket from switch.
- 6 Remove low pressure switch and refrigerant line.

b. Installation

- 1 Install new low pressure switch and refrigerant line.
- 2 Install mounting bracket, three mounting screws, and three flatwashers.
- 3 Connect three wires to switch. Install two screws. Remove tags.
- 4 Connect refrigerant line fitting to tee fitting.
- 5 Install new tie wrap around refrigerant line and discharge hose.

NOTE

If any refrigeration system components have been removed or replaced, install a new filter-drier before evacuating system (para 5-19).

- 6 Leak-test system (para 5-7).
- 7 Evacuate system (para 5-9).
- 8 Charge system (para 5-9).

5-14. CONDENSER REPLACEMENT

This task covers:

- a. Removal
- b. Installation

INITIAL SETUP

Equipment
Condition

<u>Para</u>	<u>Condition Description</u>	<u>Tools</u>
5-2	Engine stopped, power disconnected, fuel line disconnected, muffler and housing removed.	Refrigeration Unit Service Kit, item 5, appendix B
		<u>Materials/Parts</u>
5-9	Refrigeration system discharged.	Brazing alloy, item 3, appendix E
5-15	Pressure relief valve removed.	

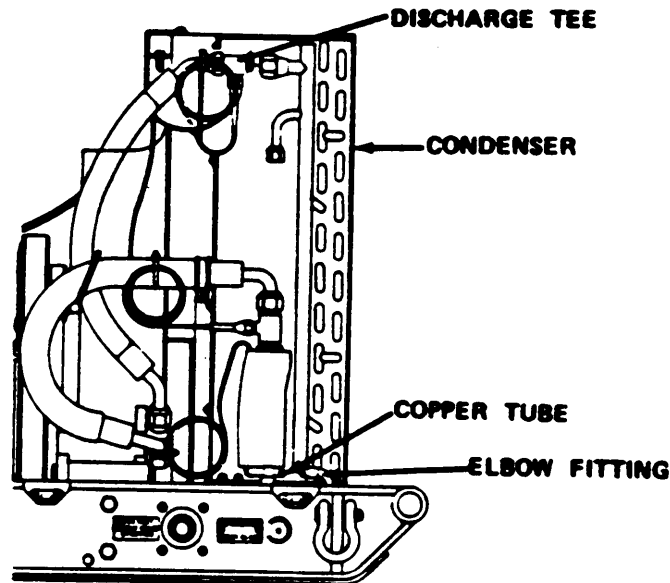

- 1 Remove discharge tee from condenser fitting.
- 2 Debraze copper tube at elbow fitting.

5-14. CONDENSER REPLACEMENT (CONT)

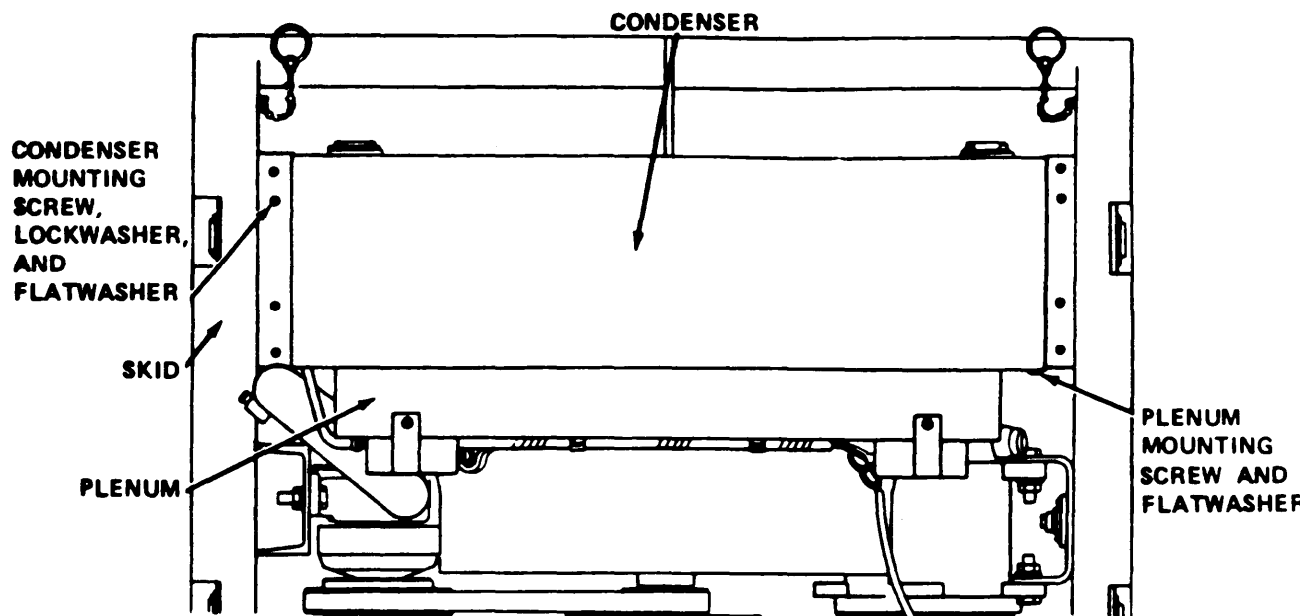

- 3 Remove eight plenum mounting screws and eight flatwashers.
- 4 Remove eight condenser mounting screws, eight lockwashers, and eight flatwashers.
- 5 Lift condenser horn skid base.

b. Installation

- 1 Install new condenser on skid base and aline mounting holes.
- 2 Install eight condenser mounting screws, eight lockwashers, and eight flatwashers.
- 3 Install eight plenum mounting screws and flatwashers.
- 4 Braze copper tube onto elbow fitting.
- 5 Install discharge tee to condenser fitting.
- 6 Install pressure relief valve (para 5-15).

NOTE

If any refrigeration system components have been removed or replaced, install a new filter-drier before evacuating system (para 5-19).

5-14. CONDENSER REPLACEMENT (CONT)

- 7 Leak-test system (para 5-7).
- 8 Evacuate system (para 5-9).
- 9 Charge system (para 5-9).

5-15. PRESSURE RELIEF VALVE REPLACEMENT

This task covers removal and installation.

INITIAL SETUP

Equipment
Condition

<u>Para</u>	<u>Condition Description</u>	<u>Tools</u>
5-2	Engine stopped power disconnected, fuel line disconnected, muffler and housing removed.	Master Mechanic's Tool Kit, item 4, appendix B
5-9	Refrigeration system discharged	

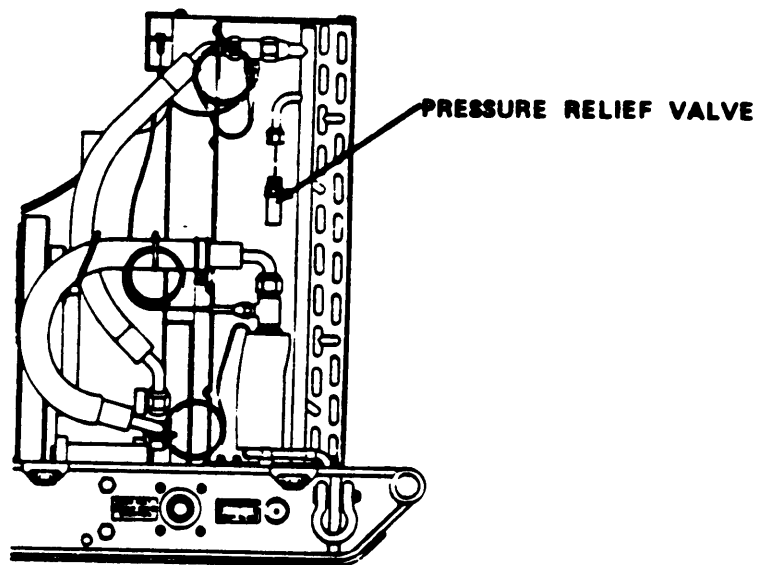

- 1 Remove pressure relief valve.
- 2 Install new pressure relief valve,

5-15. PRESSURE RELIEF VALVE REPLACEMENT (CONT)

NOTE

If any refrigeration system components have been removed or replaced, install a new filter-drier before evacuating system (para 5-19).

- 3 Leak-test system (para 5-7).
- 4 Evacuate system (para 5-9).
- 5 Charge system (para 5-9).

5-16. EXPANSION VALVE REPLAY

This task covers:

- a. Testing
- b. Removal
- c. Installation

INITIAL SETUP

Equipment
Condition

Para

Condition Description

Tools

5-2

Engine stopped, power disconnected, fuel line disconnected, muffler and housing removed.

Refrigeration Unit Service Tool Kit, item 5, appendix B

5-9

Refrigeration system discharged.

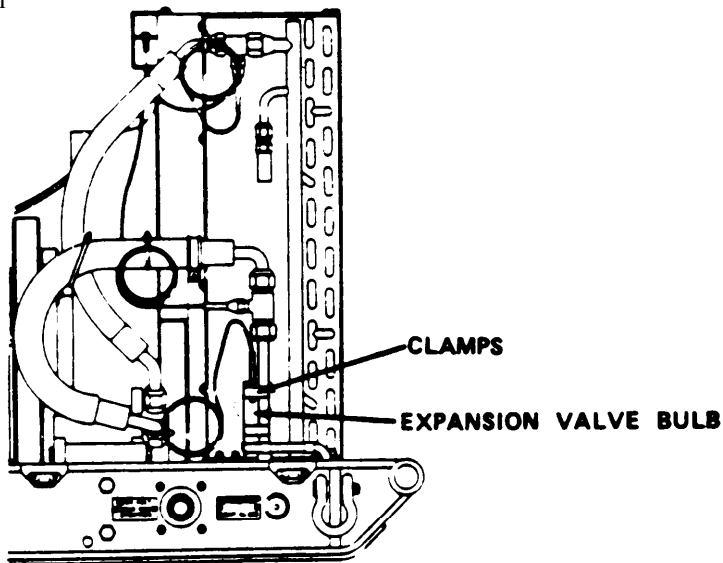

5-16. EXPANSION VALVE REPLAY (CONT)a. Testing

- 1 Locate expansion valve bulb on low pressure line between evaporator and compressor.
- 2 Cut away insulation covering expansion valve bulb being careful not to nick bulb or line.
- 3 Loosen expansion valve bulb hose clamps.
- 4 Loosen screws and carefully slide clamps free of expansion valve bulb.

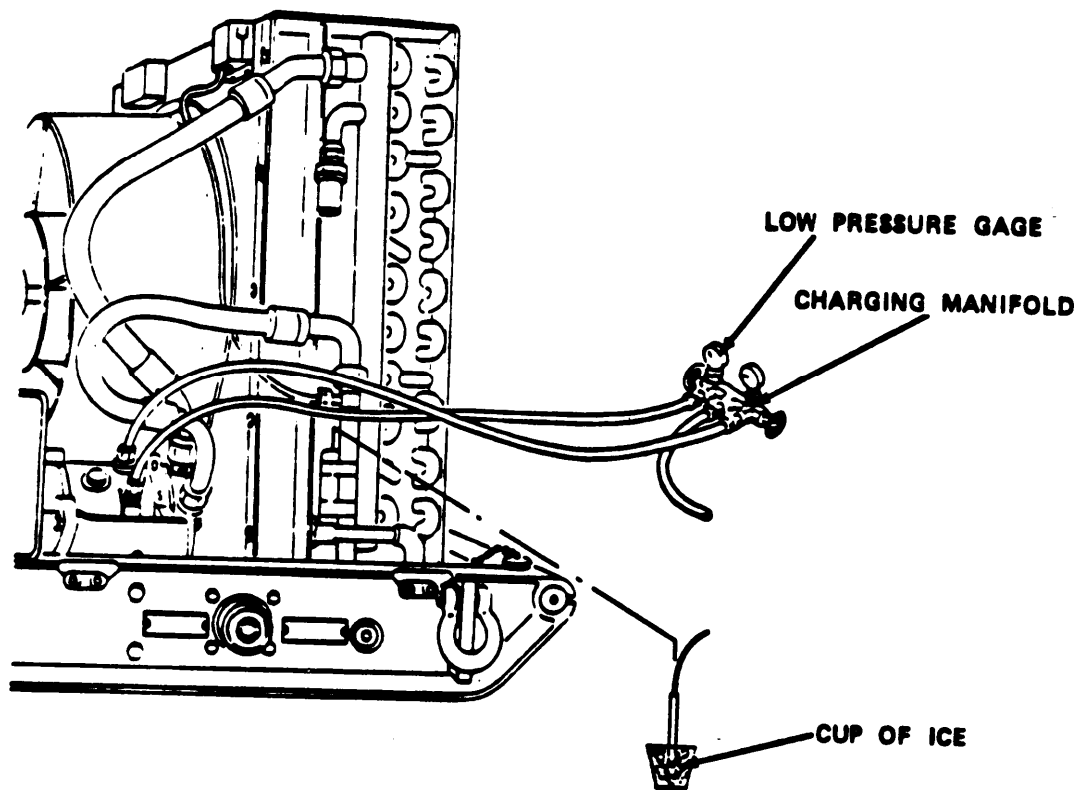

- 5 Install refrigeration charging manifold and manifold hoses (para 5-9).
- 6 Start engine (para 2-6a) and observe pressure gage on low side of charging manifold.

5-16. EXPANSION VALVE REPLAY (CONT)

- 7 Insert the expansion valve bulb in a cup of ice.

NOTE

Engine will automatically stop when refrigerant pressure drops below 35 psi (241 kPa).

- 8 Hold toggle switch S-3 in START position to prevent engine from stopping during test.
- 9 Again observe pressure gage on low side of charging manifold. Pressure should reduce to about 30 psi (207 kPa). If pressure does not reduce to this level or falls below 25 psi (172 kPa), the expansion valve is defective and should be replaced.
- 10 Stop engine and remove charging manifold and hoses (para 5-9).
- 11 Carefully slide clamps upon expansion valve bulb.
- 12 Tighten screws in expansion valve bulb clamps, ensuring good contact along the entire length of the bulb.
- 13 Replace insulation surrounding expansion valve bulb.

b. Removal

- 1 Drain engine oil (para 3-1).
- 2 Cut away insulation from expansion valve bulb.
- 3 Loosen two clamps from bulb assembly and refrigerant line.
- 4 Carefully slide clamps down and free of bulb. Cut tie wraps as needed.

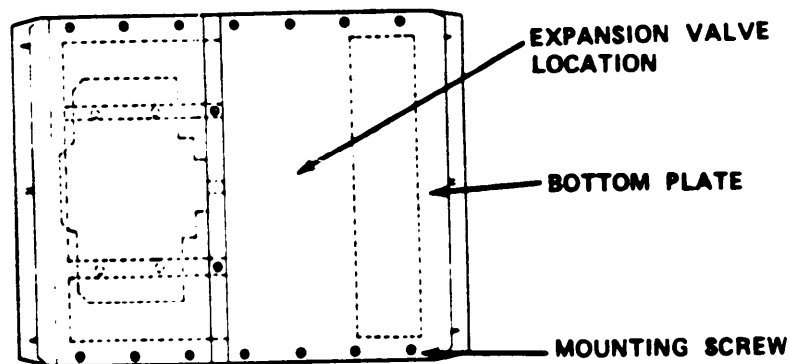

- 4 Set water chiller on its side.

5-16. EXPANSION VALVE REPLAY (CONT)

- 5 Remove 16 bottom plate mounting screws. Remove bottom plate*

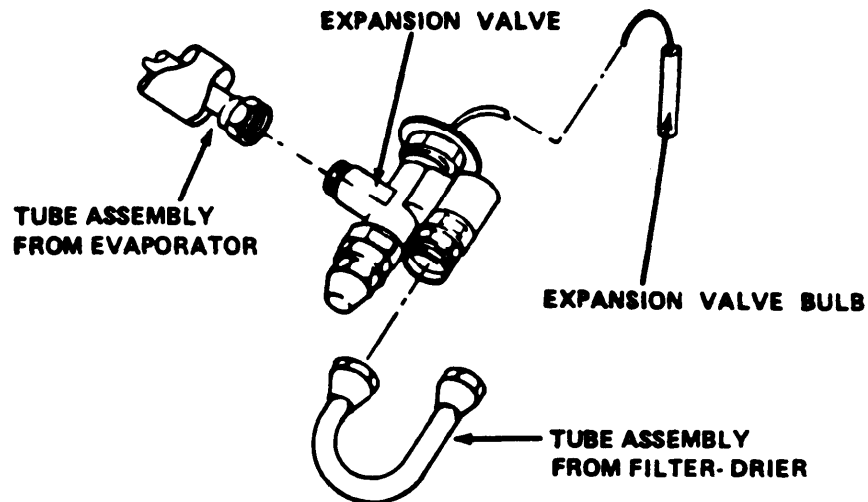

- 6 Remove tube assembly from expansion valve leading from filter drier.
- 7 Remove tube assembly from expansion valve leading from evaporator.
- 8 Remove expansion valve and bulb assembly.

c. Installation

- 1 Install new expansion valve and bulb assembly.
- 2 Install tube assembly at expansion valve leading from evaporator.
- 3 Install tube assembly at expansion valve leading from filter-drier.

NOTE

If any refrigeration system components have been removed or replaced, install a new filter-drier before evacuating system (para 5-19).

- 4 Leak-test system (para 5-7).
- 5 Install bottom plate. Install 16 bottom plate mounting screws.

5-16. EXPANSION VALVE REPLAY (CONT)

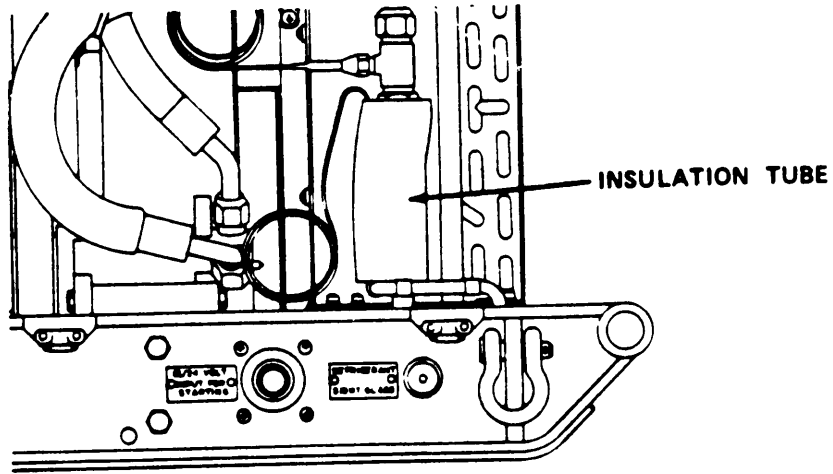

- 6 Set water chiller on skid base.
- 7 Carefully slide clamps upon expansion valve bulb. Tighten screws in hose clamps.
- 8 Install insulation tube on bulb assembly.
- 9 Add engine oil (para 3-1).
- 10 Evacuate system (para 5-9).
- 11 Charge system (para 5-9).

5-17. COMPRESSOR REPLACEMENT

This task covers:

a. Removal

b. Installation

INITIAL SETUP

Equipment

Condition

<u>Para</u>	<u>Condition</u>	<u>Description</u>	<u>Tools</u>
5-2		Engine stopped, power disconnected, fuel line disconnected, muffler and housing removed	Master Mechanic's Tool Kit, item 4, appendix B
4-14		Compressor drivebelt removed.	Common No. 1 Organizational Maintenance Automotive Maintenance and Repair Shop Eqpt, item 2, appendix B
4-19		Engine removed	<u>Materials/Parts</u>
5-9		Refrigeration system discharged.	Compressor oil, item 11, appendix E
5-10		Compressor suction hose removed.	
5-11		Compressor discharge hose removed.	

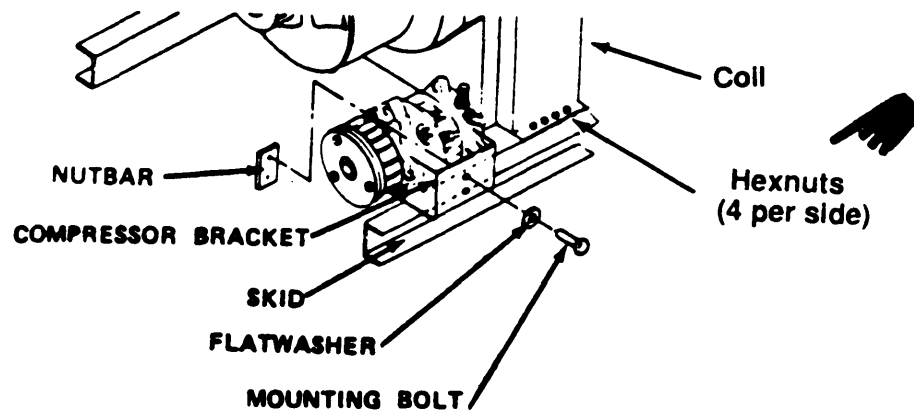

a. Removal

- 1 Remove two compressor bracket mounting bolts, two flatwashers, and nutbar.
- 2 Remove eight hex nuts, lockwashers and washers securing coil to skid.
- 3 Lift compressor and bracket from skid base.

5-17. COMPRESSOR REPLACEMENT (CONT)

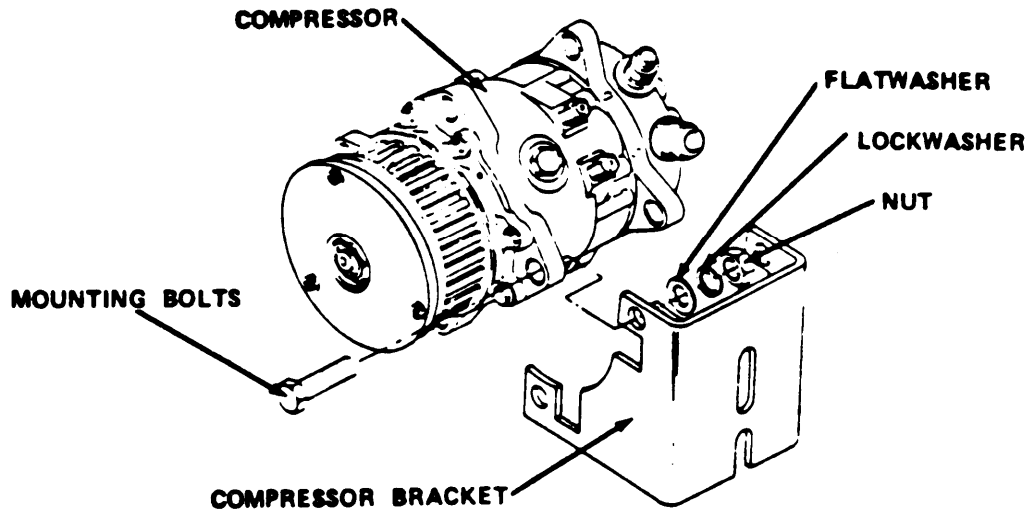

- 4 Remove four compressor mounting bolts, four nuts, four flatwashers, and four lockwashers. Remove bracket.

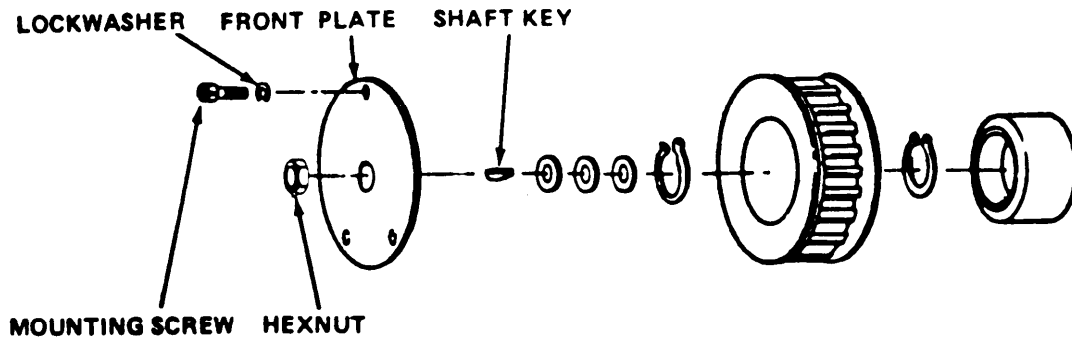

- 5 Remove hexnut in center of front plate.

NOTE

Some models of the water chiller may be equipped with two front plate mounting screws. On these models, the compressor mounting bracket must also be replaced.

- 6 Remove three front plate mounting screws and three lockwashers.
- 7 Using puller, remove front plate.
- 8 Remove shaft key.

5-17. COMPRESSOR REPLACEMENT (CONT)

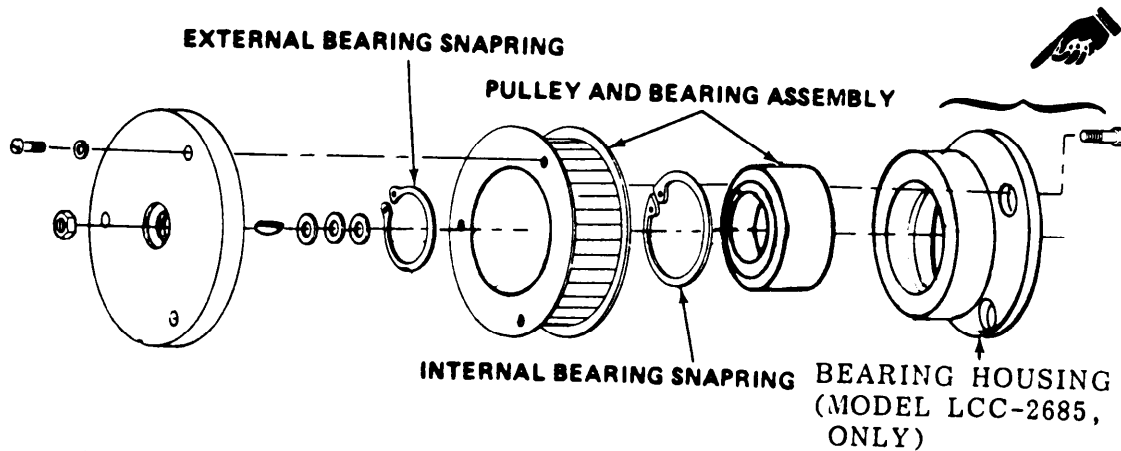

- 9 Remove internal bearing snapping.
- 10 Remove external bearing snapping.
- 11 Using puller, remove pulley and bearing assembly.

NOTE

Water chiller, Model LCC-2685, is equipped with a compressor pulley to match the new centrifugal clutch. On this model, the bearing is retained in a bearing housing and attached to the pulley with three screws.

- 12 On water chiller, Model LCC-2685, remove three screws securing the bearing housing and bearing in the pulley.

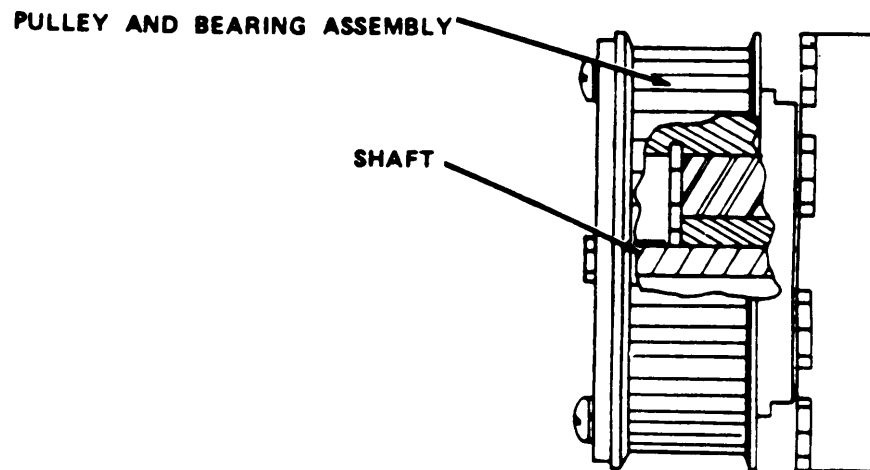

b. Installation

- 1 Drain oil from new compressor. Add 5 oz (148 ml) of this oil back to new compressor.
- 2 On water chiller, Model LCC-2685, insert bearing into the bearing housing and secure to the pulley with three screws.
- 3 Install pulley and bearing assembly on compressor shaft. Make sure assembly is flush with compressor front housing hub.

5-17. COMPRESSOR REPLACEMENT (CONT)

- 4 Install external bearing snapping.
- 5 Install internal bearing snapping.
- 6 Install shaft key.
- 7 Install front plate in alignment with shaft key.
- 8 Loosely install three mounting screws and three lockwashers in front plate.
- 9 Install hexnut in center of front plate.
- 10 Tighten three front plate mounting screws.

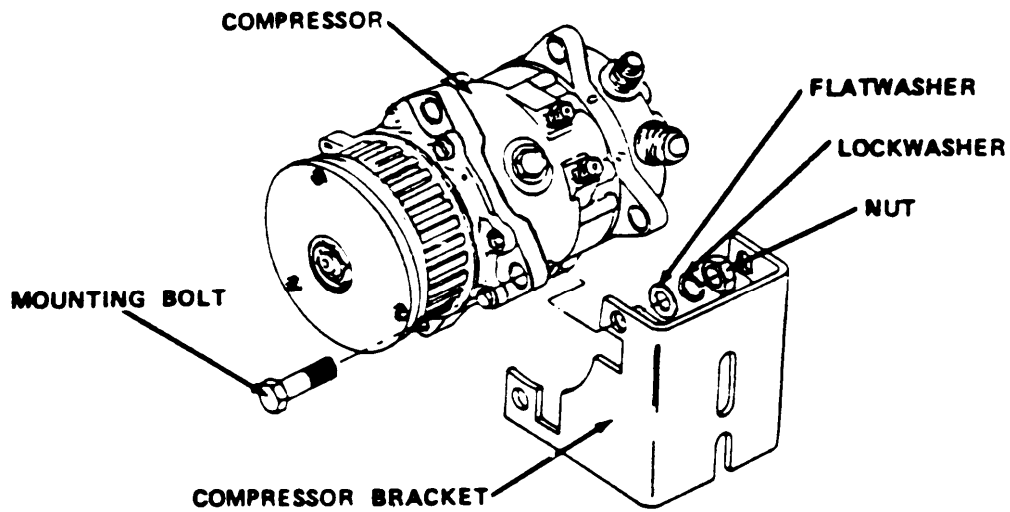

- 11 Install compressor on bracket. Install four compressor mounting bolts, four flatwashers, four lockwashers, and four nuts.

5-17. COMPRESSOR REPLACEMENT (CONT)

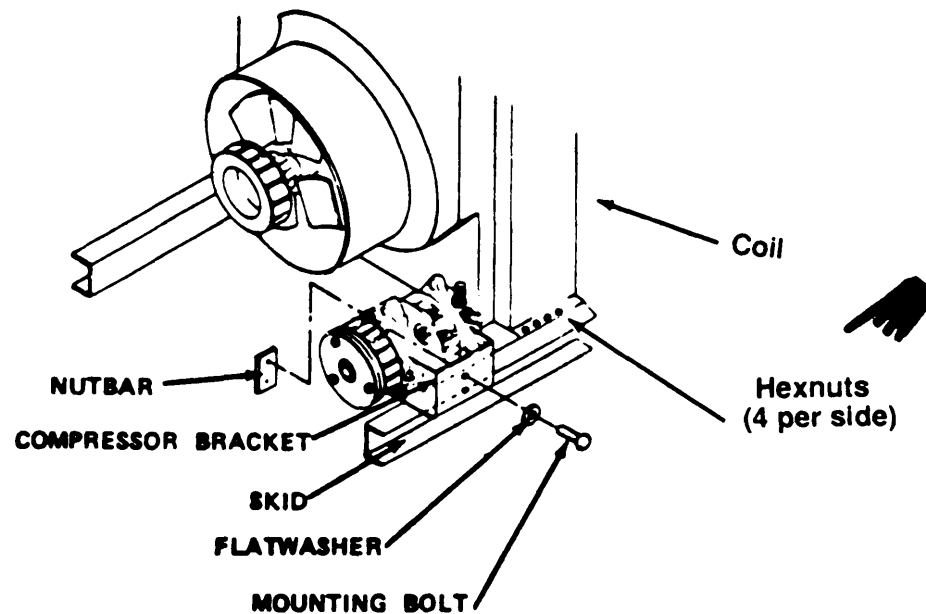

- 12 Install compressor and bracket on skid base.
- 13 Install two flatwashers, two compressor bracket mounting bolts, and nutbar. Hand-tighten.
- 14 Install engine (para 4-19).
- 15 Install compressor drivebelt and adjust (para 4-14).
- 16 Secure coil with eight hexnuts, lockwashers and washers to skid.
- 17 Install suction hose on compressor (para 5-10).
- 18 Install discharge hose on compressor (para 5-11).

NOTE

If any refrigeration system components have been removed or replaced, install a new filter-drier before evacuating system (para 5-19).

- 19 Leak-test system (para 5-7).
- 20 Evacuate system (para 5-9).
- 21 Charge system (para 5-9).

5-18. COMPRESSOR REPAIR

This task covers

- a. Removal of Cylinder Head and Valve Plate
- b. Installation of Cylinder Head and Valve Plate
- c. Removal of Shaft Seal
- d. Installation of Shaft Seal

INITIAL SETUP

Equipment

Condition

Para Condition Description

Tools

5-2	Engine stopped power disconnected, fuel line disconnected, muffler and housing removed.	Master Mechanic's Tool Kit, item 4, appendix B Materials/Parts
5-17	Compressor removed.	Compressor oil, item 11, appendix E

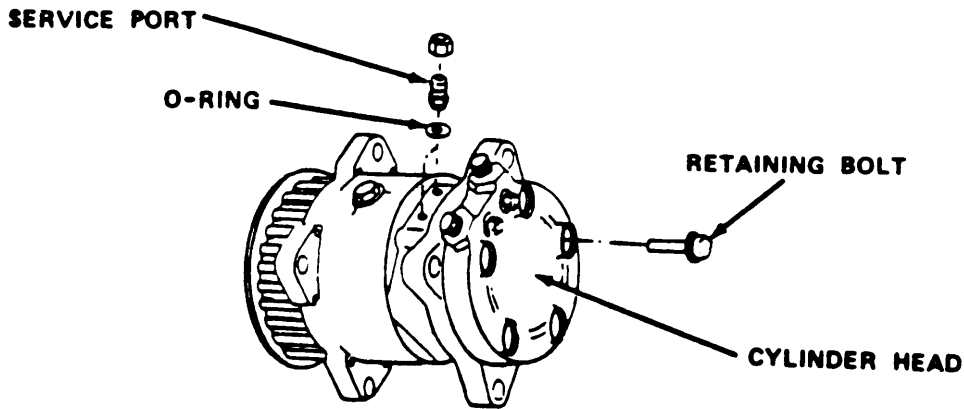

a. Removal of Cylinder Head and Valve Plate

- 1 Remove two complete service ports.
- 2 Remove service port O-rings.
- 3 Remove five cylinder head retaining bolts.
- 4 Tap lightly on outer edge of cylinder head until it is free of valve plate. Remove cylinder head,

5-18 COMPRESSOR REPAIR (CONT)

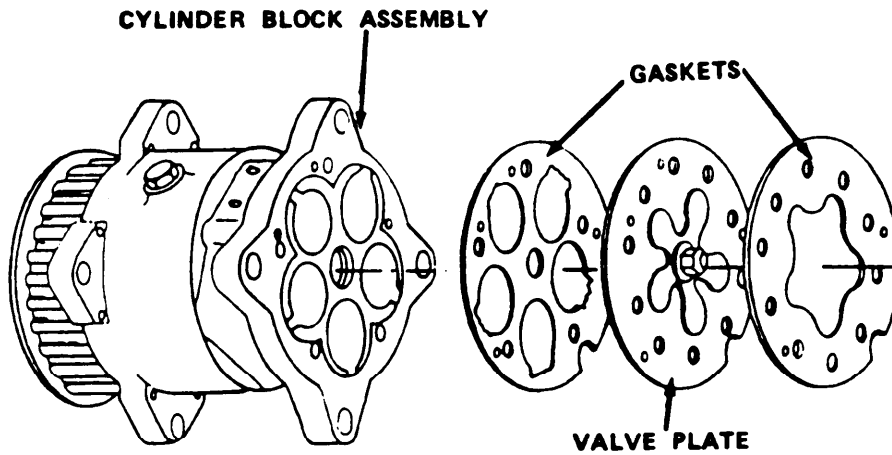

- 5 Separate valve plate from cylinder block assembly. Remove valve plate.

CAUTION

To prevent damage to parts, be very careful when scraping off gasket materials.

- 6 Carefully scrape gasket materials from cylinder block, valve plate, and cylinder head.
- 7 Inspect parts for damage and replace as needed.

b. Installation of Cylinder Head and Valve Plate

- 1 Coat new valve plate gasket with clean compressor oil (VV-L-825).
- 2 Install valve plate gasket. Install valve plate.

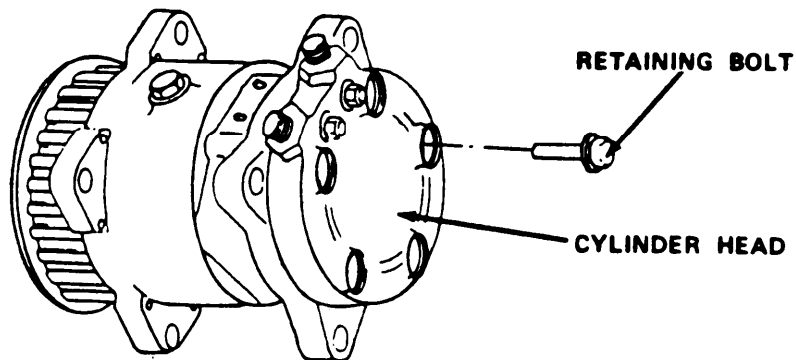

5-18. COMPRESSOR REPAIR (CONT)

- 3 Coat new cylinder head gasket with clean compressor oil (W-L-825).
- 4 Install cylinder head gasket. Install cylinder head.
- 5 Insert cylinder head retaining bolts and hand-tighten.

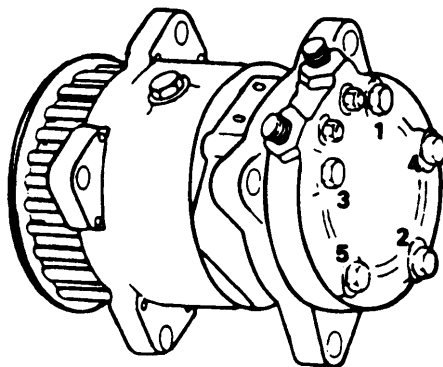

- 6 Torque cylinder head retaining bolts to 22 to 25 ft lb (30 to 34 Nm) in sequence with torque pattern above.

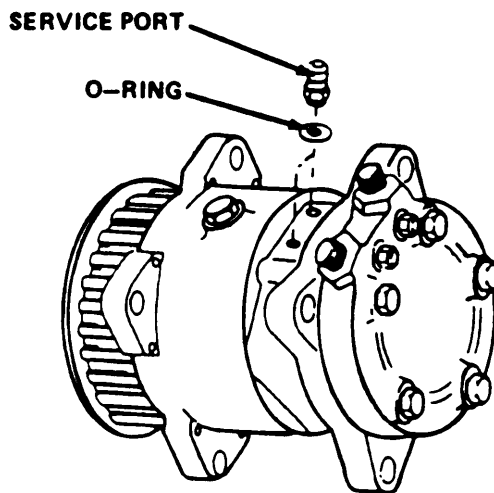

- 7 Install two new service port O-rings.
- 8 Install two complete service ports.
- 9 Install compressor (para 5-17).

5-18. COMPRESSOR REPAIR (CONT)

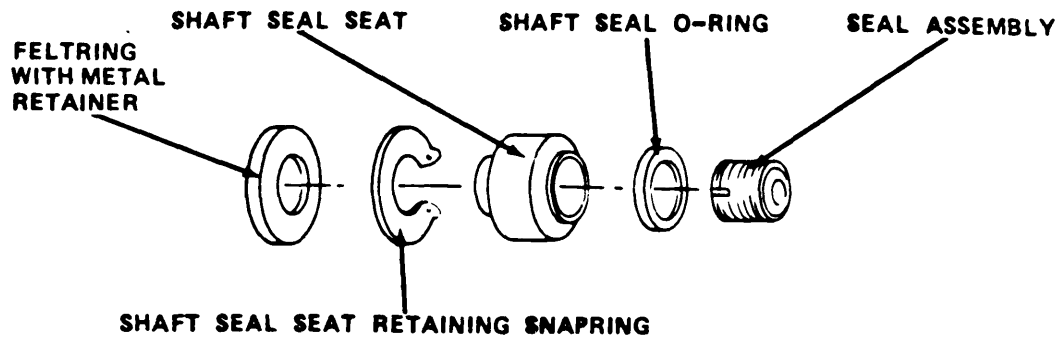

c. Removal of Shaft Seal

- 1 Remove felting with metal retainer.
- 2 Remove shaft seal seat retaining snapping.
- 3 Remove shaft seal seat.
- 4 Remove shaft seal O-ring.
- 5 Remove seal assembly.

d. Installation of Shaft Seal

- 1 Clean seal cavity thoroughly.

CAUTION

To prevent damage to seal, DO NOT touch new seal lapping surfaces.

- 2 Coat mating surfaces with clean compressor oil (VV-L-825). Install seal assembly.
- 3 Coat O-ring with clean compressor oil (VV-L-825).
- 4 Install O-ring in seal groove.
- 5 Coat shaft seal seat with clean compressor oil (W-L-825).

5-18. COMPRESSOR REPAIR (CONT)

- 6 Install shaft seal seat lightly against seal.
- 7 Install shaft seal seat retaining snapping.
- 8 Install feltring with metal retainer.
- 9 Install compressor (para 5-17).

5-19. FILTER-DRIER REPLACEMENT

This task covers:

- a. Removal
- b. Installation

INITIAL SETUP

Equipment

Condition

Para Condition Description

Tools

5-2 Engine stopped, power disconnected, fuel line disconnected, muffler and housing removed.

Master Mechanic's Tool Kit, item 4, appendix B

5-9 Refrigeration system discharged.

3-1 Engine oil drained.

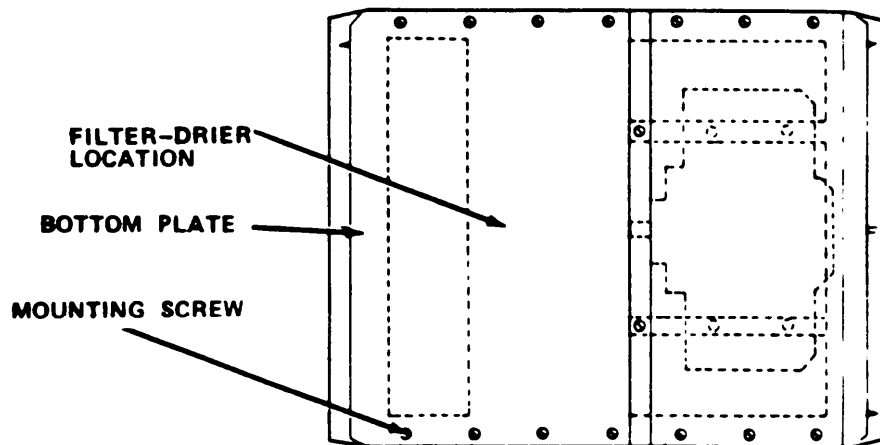

5-19. FILTER-DRIER REPLACEMENT (CONT)

a. Removal

- 1 Set water chiller on its side.
- 2 Remove 16 bottom plate mounting screws. Remove bottom plate.

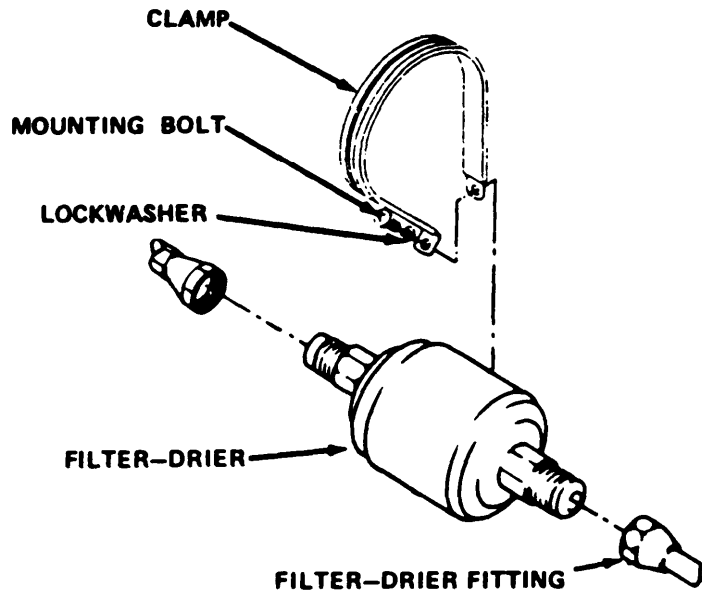

- 3 Remove clamp mounting bolt and lockwasher.
- 4 Remove filter-drier fittings. Remove filter-drier.
- 5 Slide clamp off filter-drier.

b. Installation

- 1 Slide new filter-drier into clamp.
- 2 Install clamp mounting bolt
- 3 Install filter-drier. Connect filter-drier fittings.
- 4 Install bottom plate. Install 16 bottom plate mounting screws.
- 5 Set water chiller back on skid base.

5-19. FILTER-DRIER REPLACEMENT (CONT)

- 6 Add oil (para 3-1).
- 7 Leak-test system (para 5-7).
- 8 Evacuate system (para 5-9).
- 9 Charge system (para 5-9).

5-20. WATER SYSTEM LEAK TEST

This task covers testing only.

Equipment Condition		Equipment Condition	
<u>Para</u>	<u>Condition</u>	<u>Para</u>	<u>Condition</u>
	<u>Description</u>		<u>Description</u>
5-2	Engine stopped, power disconnected, fuel line disconnected, muffler and housing removed.	5-23	Water chiller on its side, bottom plate and foam removed.

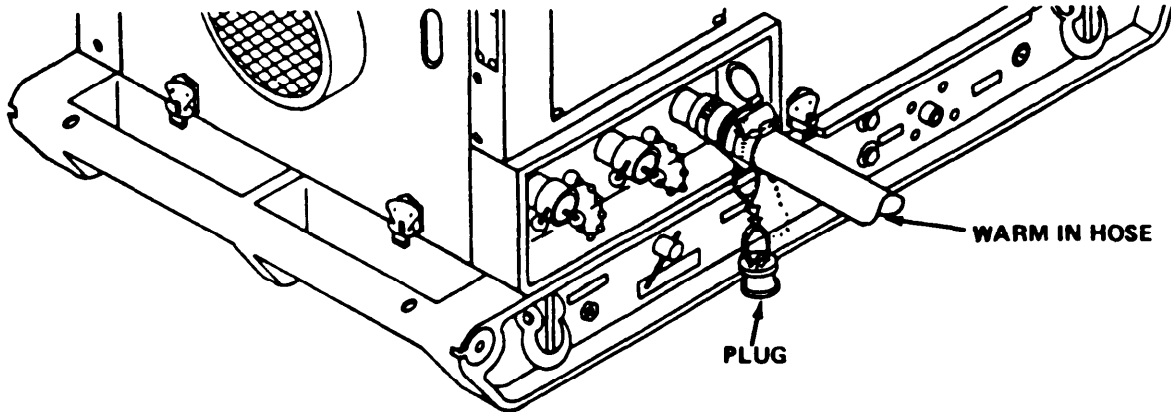

- 1 Place shipping plugs in COOL RECIRCULATE and COOL DISPENSE connections. Close cam arms.

5-20. WATER SYSTEM LEAK TEST (CONT)

- 2 Connect shop water source to WARM IN connection. Turn on water.
- 3 Check all fittings for leaks.

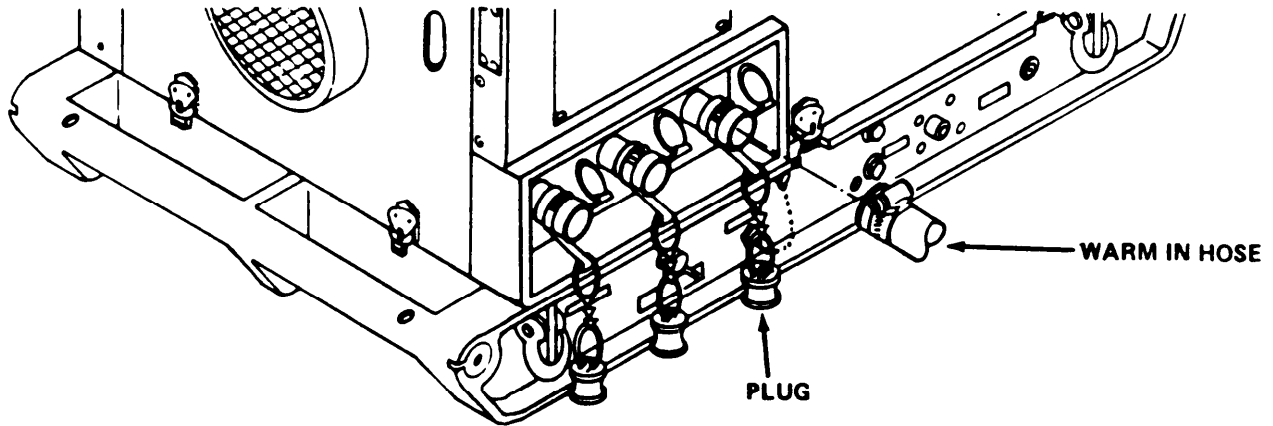

- 4 After 3 minutes turn off water. Remove shop water source from WARM IN connection. Remove shipping plugs from COOL RECIRCULATE and COOL DISPENSE connections. Allow water to drain.
- 5 Repair any leaks found and retest.

5-21. WATER PUMP REPAIR

This task covers:

- a. Disassembly
- b. Assembly

INITIAL SETUP

Equipment

Condition

Para Condition Description

Tools

5-2 Engine stopped, power disconnected, fuel line disconnected, muffler and housing removed.

Basic Field Maintenance
Automotive Maintenance and Repair Shop Eqpt, item 3, appendix B

4-31 Water pump removed.

5-21. WATER PUMP REPAIR (CONT)

Materials/Parts

Grease, item 9, appendix F

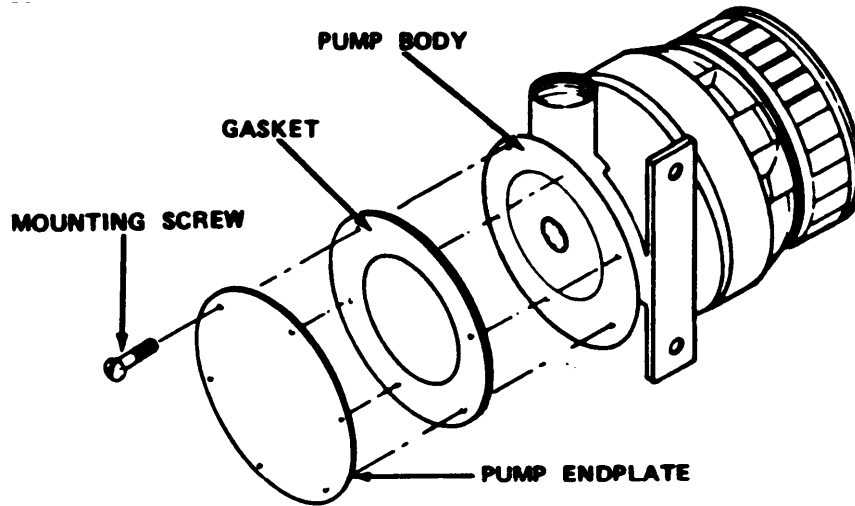

a. Disassembly

- 1 Remove two remaining pump end plate mounting screws. Remove endplate.
- 2 Completely scrape old gasket off pump body and cover plate.

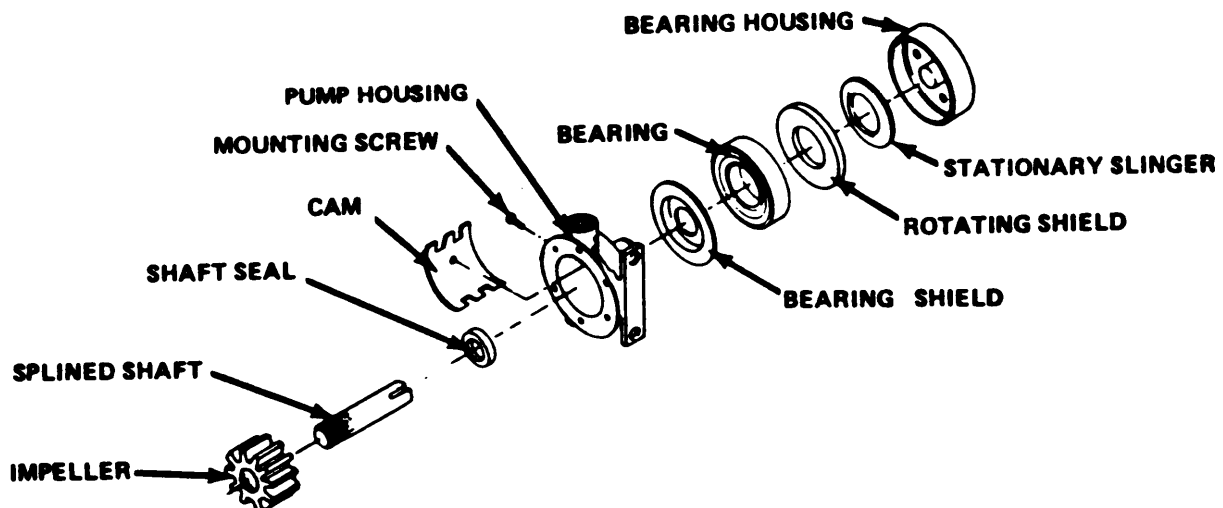

5-21. WATER PUMP REPAIR (CONT)

- 3 Remove impeller from splined shaft.
- 4 Remove cam mounting screw. Remove cam.
- 5 Tap splined shaft and bearing housing out of pump housing.
- 6 Drive shaft seal from pump housing.
- 7 Remove rotating shield and stationary slinger.
- 8 Remove bearing from pump housing.
- 9 Remove bearing shield from pump housing.

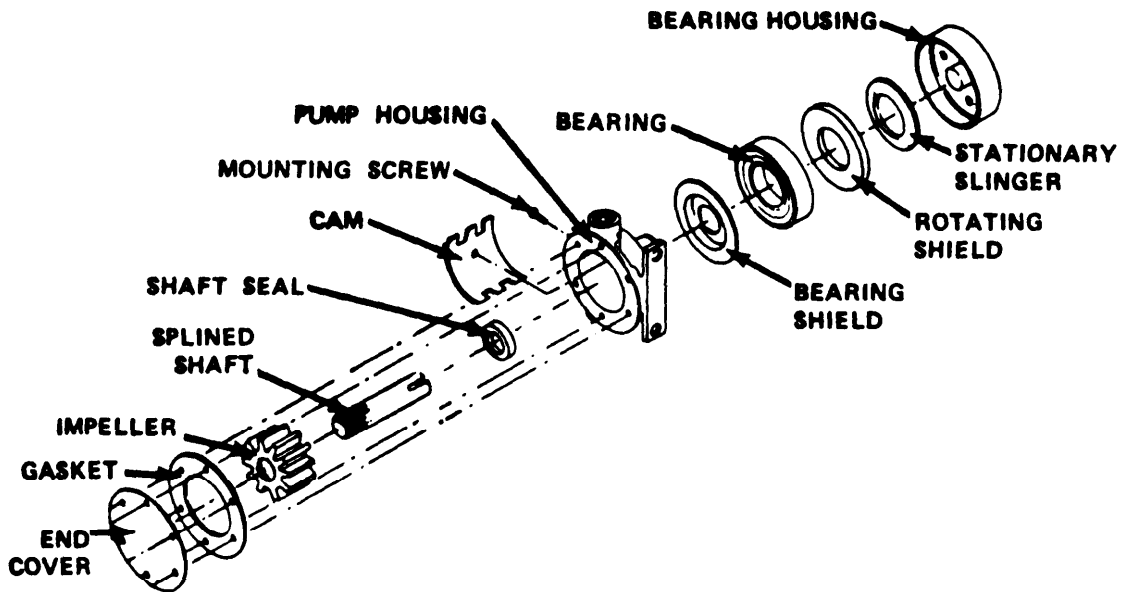

5-21. WATER PUMP REPAIR (CONT)

a. Assembly

- 1 Install bearing shield on pump housing.
- 2 Press bearing onto pump housing.
- 3 Install rotating shield and stationary slinger.
- 4 Press splined shaft and bearing housing into pump housing.
- 5 Install new shaft seal over splined shaft and into pump housing.
- 6 Install cam. Install cam mounting screw.
- 7 Lubricate impeller bore with a light coat of grease.
- 8 Install new impeller on splined shaft.
- 9 Install new gasket on water pump body.
- 10 Install endplate. Install two endplate mounting screws.
- 11 Install water pump (para 4-3 1).

5-22. EVAPORATOR REPLACEMENT

This task covers:

a. Removal

b. Installation

INITIAL SETUP

Equipment

Tools

Condition

Para Condition Description

Refrigeration Unit Service Tool
Kit item 5, appendix B

5-2 Engine stopped, power
 disconnected, fuel line
 disconnected muffler
 and housing removed.

Polyurethane foam, item 13,
appendix E

5-9 Refrigeration system
 discharged.

Brazing alloy, item 3,
appendix E

3-1 Engine oil drained.

5-22. EVAPORATOR REPLACEMENT (CONT)

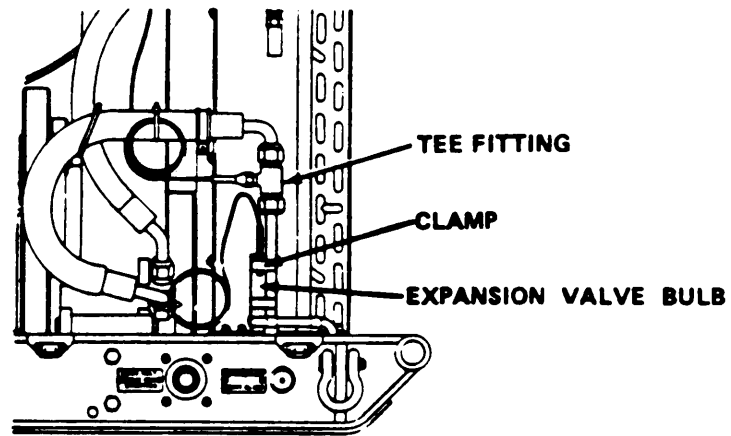

a. Removal

- 1 Cut away foam insulation away from expansion valve bulb.
- 2 Remove two clamps from expansion valve bulb and refrigerant line. Move bulb aside.
- 3 Remove evaporator pipe fitting from low pressure switch tee fitting.

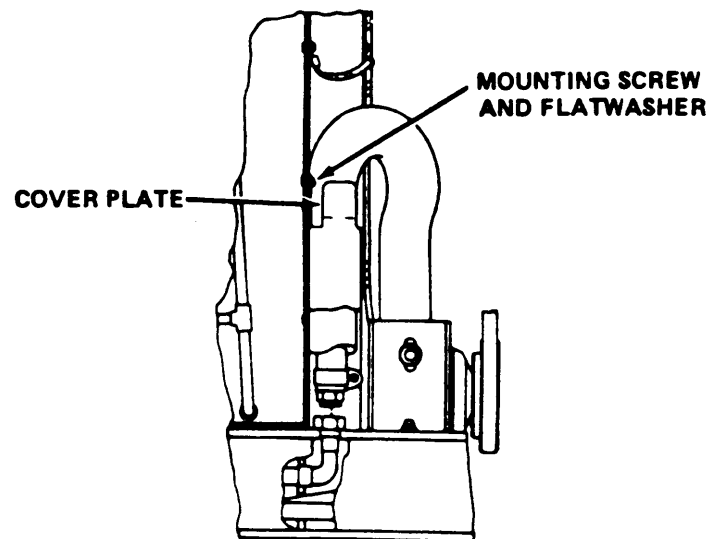

5-22. EVAPORATOR REPLACEMENT (CONT)

- 4 Remove mounting screw and flatwasher. Remove upper water pump hose cover plate.
- 5 Pull back insulation, loosen hose clamp, and remove upper water pump hose.
- 6 Remove hose fitting from evaporator.

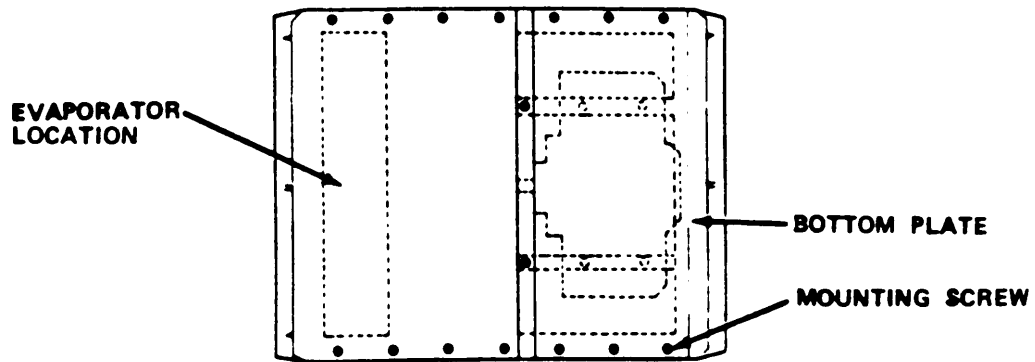

- 7 Set water chiller on its side.
- 8 Remove 16 bottom plate mounting screws. Remove bottom plate.

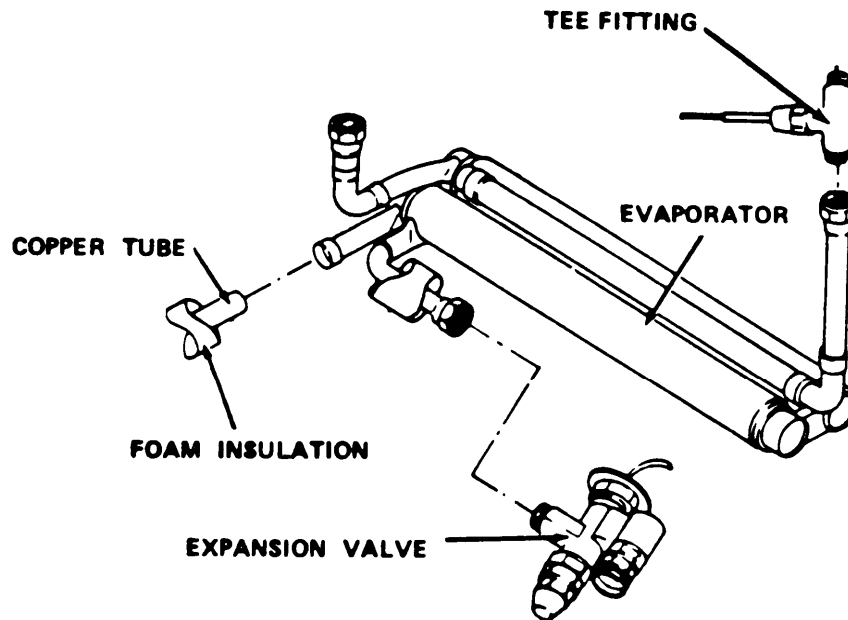

5-22. EVAPORATOR REPLACEMENT (CONT)

- 9 Remove evaporator pipe fitting from expansion valve.
- 10 Cut black foam insulation away from remaining evaporator fitting.
- 11 Debraze evaporator fitting from copper tube.
- 12 Break up foam around evaporator. Remove evaporator.

b. Installation

- 1 Install evaporator.
- 2 Install evaporator pipe fitting at expansion valve.
- 3 Braze evaporator fitting to copper tubing.
- 4 Install black foam insulation around copper tube.
- 5 Set water chiller on skid base.
- 6 Install hose fitting to evaporator.
- 7 Install upper water pump hose on hose fitting. Tighten hose clamp. Install black foam insulation.
- 8 Install water pump hose cover plate, mounting screw, and flatwasher.
- 9 Install evaporator pipe fitting to low pressure switch tee fitting.
- 10 Fasten expansion valve bulb hose clamps to evaporator pipe.
- 11 Carefully slide expansion valve bulb down into hose clamps. Tighten hose clamps.
- 12 Install black foam insulation over expansion valve bulb.
- 13 Set water chiller on its side.
- 14 Fill in open areas with polyurethane foam.
- 15 Install bottom plate. Install 16 bottom plate mounting screws.

5-22. EVAPORATOR REPLACEMENT (CONT)

16 Set water chiller on skid base.

17 Add oil (para 3-1).

NOTE

If any refrigeration system components have been removed or replaced, install a new filter-drier before evacuating system (para 5-19).

18 Leak-test system (para 5-7).

19 Evacuate system (para 5-9).

20 Charge system (para 5-9).

5-23. RELIEF VALVE REPLACEMENT

This task covers:

a. Removal

b. Installation

INITIAL SETUP

Equipment
Condition

<u>Para</u>	<u>Condition</u>	<u>Description</u>
5-2	Engine stopped, power disconnected, muffler and housing removed.	
3-1	Engine oil drained.	

Tools

Common No. 1 Organizational Maintenance Automotive Maintenance and Repair Shop Eqpt, item 2, appendix B

Materials/Parts

Polyurethane foam, item 13, appendix E

Solder, item 19, appendix E

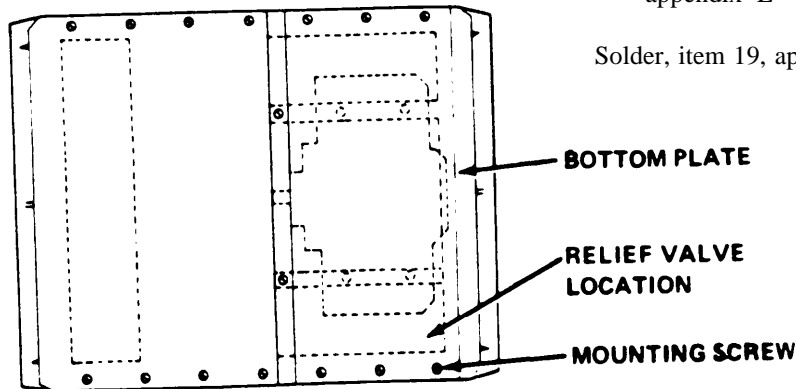

5-23. RELIEF VALVE REPLACEMENT (CONT)

a. Removal

- 1 Set water chiller on its side.
- 2 Remove 16 bottom plate mounting screws. Remove bottom plate.
- 3 Break up foam insulation to access relief valve on side of skid.

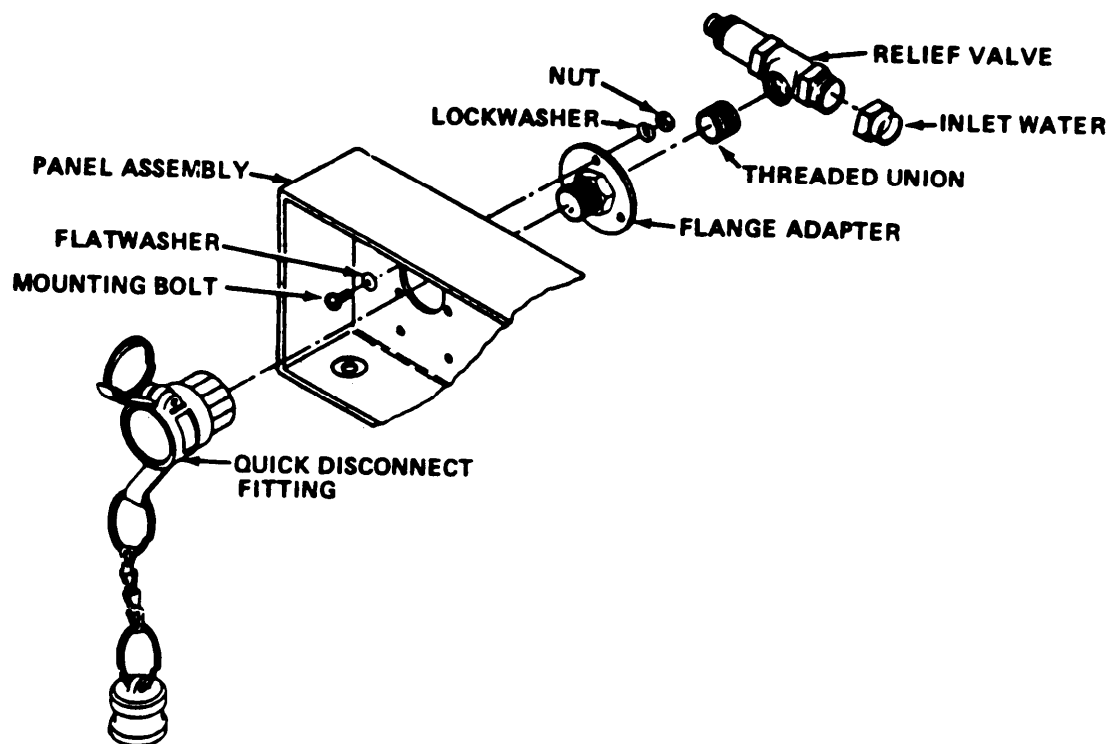
**WARNING**

Polyurethane foam is flammable. Burning foam causes toxic fumes. When soldering, be very careful not to ignite foam.

- 4 Desolder joints as needed. Remove inlet water line from valve assembly.

5-23. RELIEF VALVE REPLACEMENT (CONT)

- 5 Remove cool recirculate quick-disconnect fitting from panel assembly.
- 6 Remove three mounting bolts, three nuts, three lockwashers, and three flatwashers from panel assembly and flange adapter.
- 7 Remove flange adapter and threaded union from relief valve.
- 6 Remove relief valve.

b. Installation

- 1 Install relief valve.
- 2 Install flange adapter and threaded union to relief valve.
- 3 Install inlet water line on relief valve.
- 4 Resolder any desoldered joints.
- 5 Install three mounting bolts, three nuts, three lockwashers, and three flatwashers to panel assembly and flange adapter.
- 6 Install cool recirculate quick-disconnect fitting to panel assembly.
- 7 Leak-test system (para 5-7).
- 8 Fill in open areas with polyurethane foam.
- 9 Install bottom plate. Install 16 bottom plate mounting screws.
- 10 Set water chiller on skid base.
- 11 Add oil (para 3-1).

5-24. THERMOSTATIC VALVE REPLACEMENT

This task covers:

- a. Removal
- b. Installation

5-24. THERMOSTATIC VALVE REPLACEMENT (CONT)

INITIAL SETUP

Equipment
Condition

<u>Para</u>	<u>Condition</u>	<u>Description</u>	<u>Tools</u>
5-2		Engine stopped, power disconnected, muffler and housing removed.	Common No. 1 Organizational Maintenance Automotive Maintenance and Repair Shop Eqpt, item 15, appendix B
3-1		Engine oil drained.	

Materials/Parts

Polyurethane foam, item 13, appendix E

Solder, item 19, appendix E

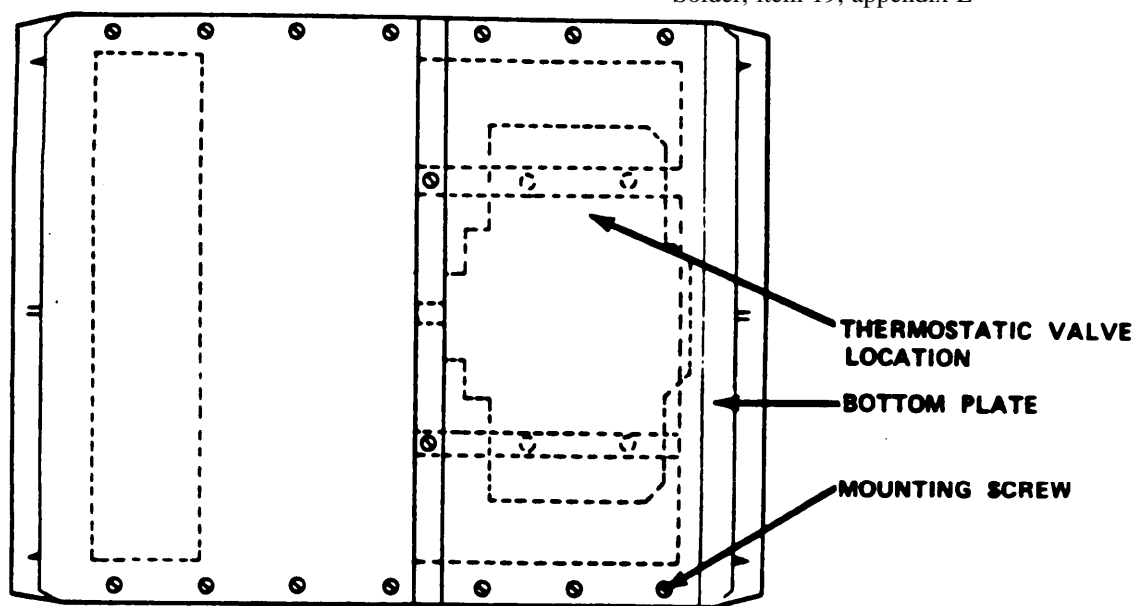

a. Removal

- 1 Set water chiller on its side.
- 2 Remove 16 bottom plate mounting screws. Remove bottom plate.
- 3 Break up foam around thermostatic valve.

5-24. THERMOSTATIC VALVE REPLACEMENT (CONT)

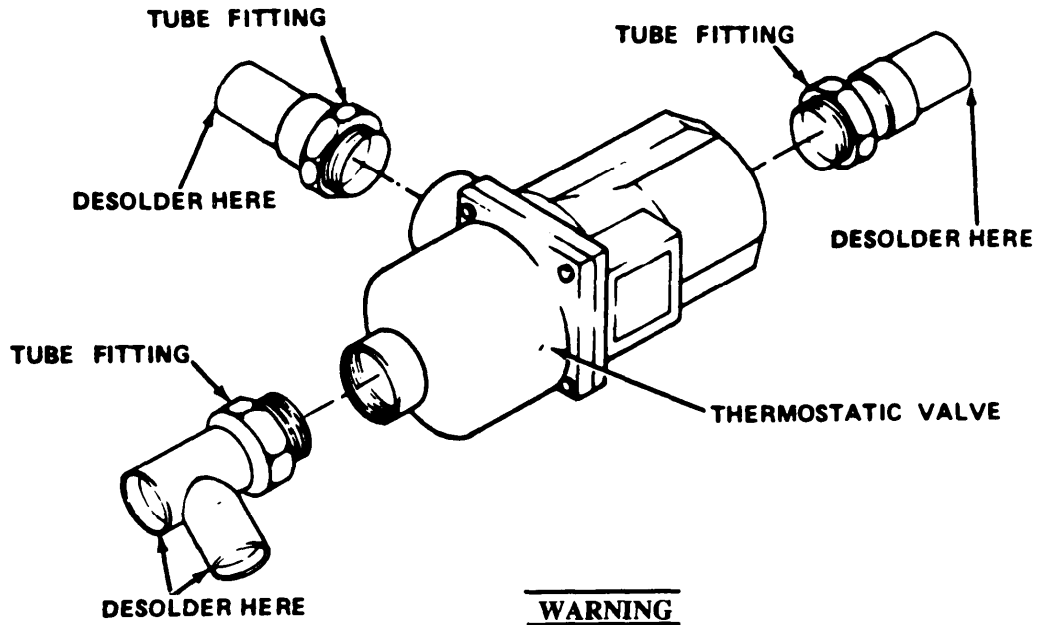

Polyurethane foam is flammable. Burning foam causes toxic fumes. When soldering, be very careful not to ignite foam.

NOTE

Desolder as needed to remove fittings from thermostatic valve.

- 4 Remove tube fitting from side of thermostatic valve.
- 5 Remove tube fitting from front of thermostatic valve.
- 6 Remove tube fitting from back of thermostatic valve.
- 7 Remove thermostatic valve assembly.

b. Installation

- 1 Install tube fittings on new thermostatic valve.
- 2 Install thermostatic valve in bottom of skid.

5-24. THERMOSTATIC VALVE REPLACEMENT (CONT)

WARNING

Polyurethane foam is flammable. Burning foam causes toxic fumes. When soldering, be very careful not to ignite foam.

- 3 Solder as needed to install fittings on tubing.
- 4 Fill in open areas with polyurethane foam.
- 5 Install bottom plate. Install 16 bottom plate mounting screws.
- 6 Set water chiller on skid base.
- 7 Add oil (para 3-1).

5-25. THERMOSTATIC VALVE REPAIR

This task covers:

- a. Disassembly
- b. Assembly

INITIAL SETUP

Equipment
Condition

<u>Para</u>	<u>Condition Description</u>	<u>Tools</u>
5-2	Engine stopped, power disconnected, fuel line disconnected, muffler and housing removed.	Master Mechanic's Tool Kit, item 4, appendix B
		<u>Materials/Parts</u>
5-24	Thermostatic valve removed.	Grease, item 9, appendix E

NOTE

Repair of the thermostatic valve consists of replacement of defective parts. During disassembly of valve inspect parts for wear and damage. Replace worn or damaged parts.

5-25. THERMOSTATIC VALVE REPAIR (CONT)

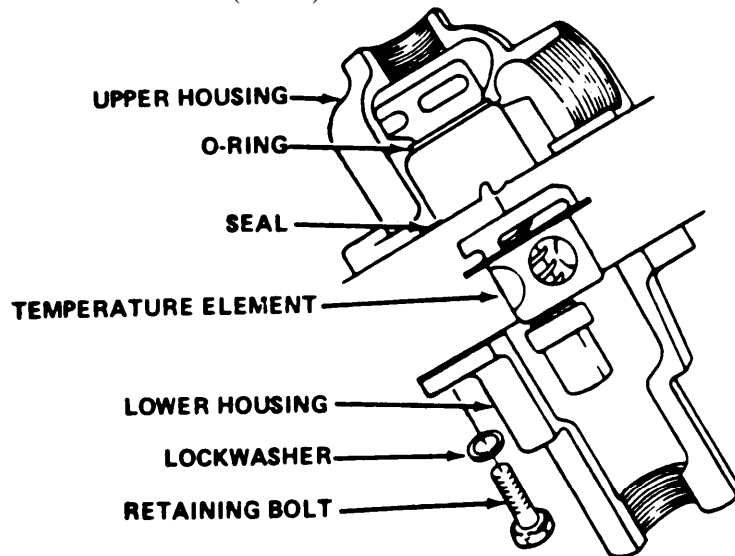

a. Disassembly

- 1 Remove four lower housing retaining bolts and lockwashers.
- 2 Separate lower housing from upper housing.
- 3 Remove seal from upper housing.
- 4 Remove temperature element assembly from upper housing.
- 5 Remove O-ring from temperature element assembly.

b. Assembly

- 1 Lubricate O-ring and seal with a light coat of grease.
- 2 Install O-ring on new temperature element assembly.
- 3 Install temperature element assembly in upper housing.
- 4 Install seal in upper body.
- 5 Install lower housing on upper housing.
- 6 Install four lower housing retaining bolts.
- 7 Install thermostatic valve (para 5-24).

5-26. BALL VALVE ASSEMBLY REPLACEMENT

This task covers:

- a. Removal
- b. Installation

INITIAL SETUP

Equipment

Tools

Condition

<u>Para</u>	<u>Condition Description</u>
5-2	Engine stopped, power disconnected, fuel line disconnected muffler and housing removed.

Common No. 1 Organizational Maintenance Automotive Maintenance and Repair Shop Eqpt, item 2, appendix B

Materials/Parts

3-1	Engine oil drained.
-----	---------------------

Polyurethane foam, item 13, appendix E

Solder, item 19, appendix B

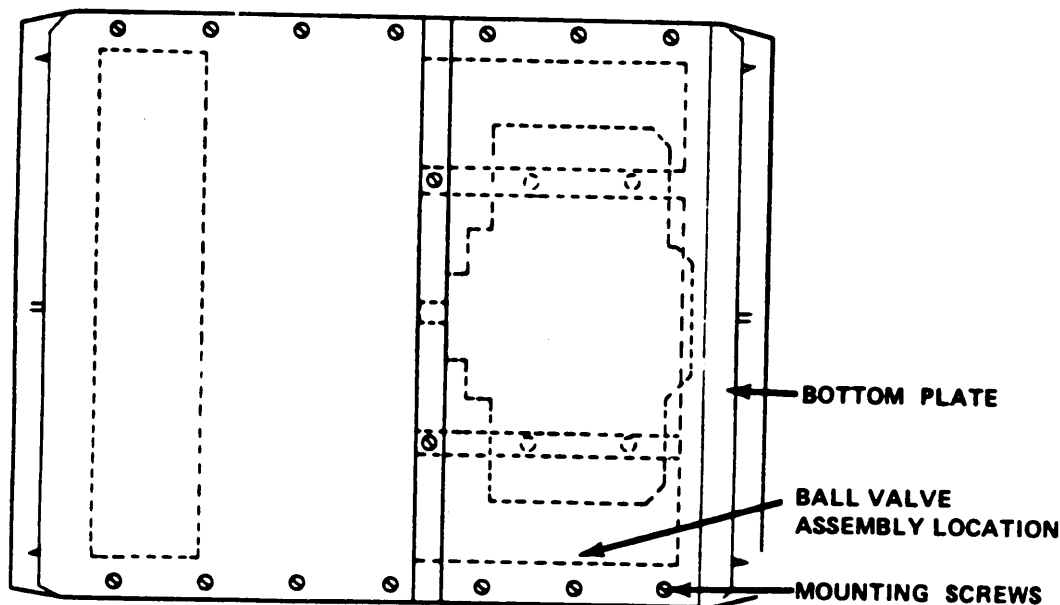

a. Removal

- 1 Set water chiller on its side.
- 2 Remove 16 bottom plate mounting screws. Remove bottom plate.
- 3 Break up foam insulation around ball valve assembly.

5-26. BALL VALVE ASSEMBLY REPLACEMENT (CONT)

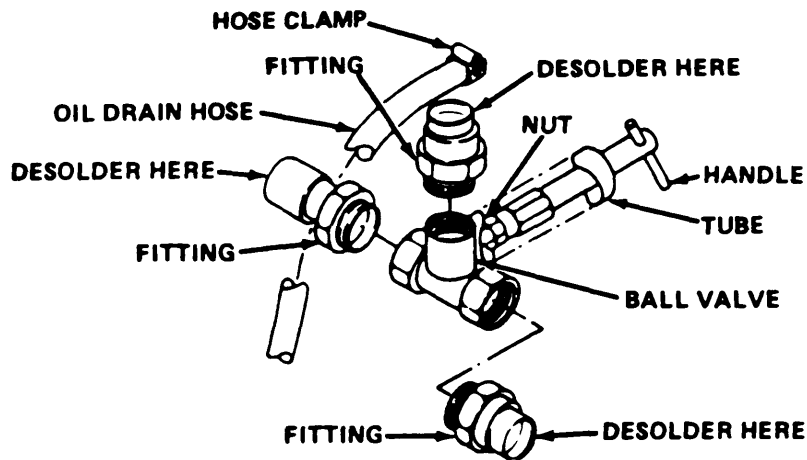

- 4 Drive out handle. Remove oil drain hose clamp. Remove oil drain hose.
- 5 Remove valve handle mounting nut and tube.

Polyurethane foam is flammable. Burning foam causes toxic fumes. When soldering, be very careful not to ignite foam.

NOTE

Desolder fittings as needed to remove from valve assembly.

- 6 Remove ball valve assembly.
- 7 Remove fitting from right side of valve assembly.
- 8 Remove fitting from left side of valve assembly.
- 9 Remove fitting from top side of valve assembly.

b. Installation

- 1 Install fittings in valve assembly.

5-26. BALL VALVE ASSEMBLY REPLACEMENT (CONT)

- 2 Install ball valve assembly in bottom of skid.

WARNING

Polyurethane foam is flammable. Burning foam causes toxic fumes. When soldering, be very careful not to ignite foam.

- 3 Solder fittings to tubing.
- 4 Perform water leak test (para 5-20).
- 5 Fill in open area with polyurethane foam.
- 6 Install bottom plate. Install 16 bottom plate mounting screws.
- 7 Set water chiller on skid base.
- 8 Add oil (para 3-1).

5-27. LOW TEMPERATURE THERMAL SWITCH REPLACEMENT

This task covers:

- a. Removal
- b. Installation

5-27. LOW TEMPERATURE THERMAL SWITCH REPLACEMENT (CONT)

INITIAL SETUP

Equipment
Condition

<u>Para</u>	<u>Condition Description</u>	<u>Tools</u>
5-2	Engine stopped, power disconnected, fuel line disconnected, muffler and housing removed.	Common No. 1 Organizational Maintenance Automotive Maintenance and Repair Shop Equipment, item 2, appendix B
3-1	Engine oil drained.	Master Mechanic's Tool Kit, item 4, appendix B

Materials/Parts

Bonding compound, item 17, appendix E

Solder, item 20, appendix E

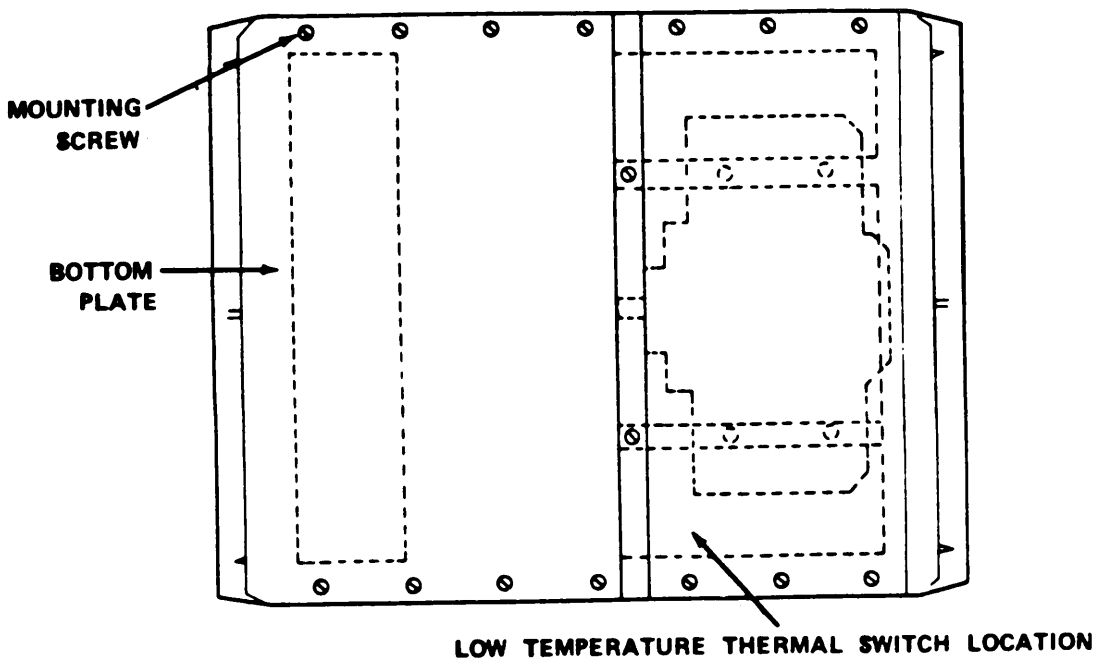

a. Removal

- 1 Turn water chiller on its side.
- 2 Remove 16 bottom plate mounting screws. Remove bottom plate.

5-27. LOW TEMPERATURE THERMAL SWITCH REPLACEMENT (CONT)

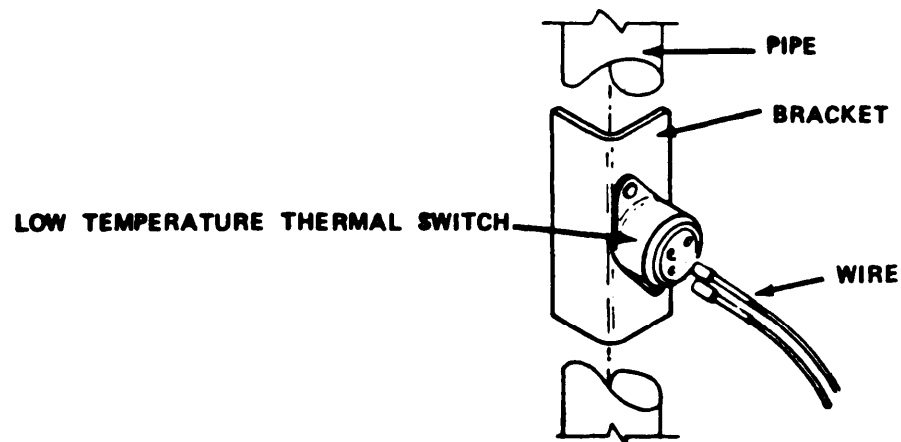

- 3 Break Up foam insulation to gain access to thermal switch located on the side of warm (inlet) pipe.

WARNING

Polyurethane foam is flammable. Burning foam causes toxic fumes. When soldering, be very careful not to ignite foam.

- 4 Desolder two wires from thermal switch. Remove wires.
- 5 Pry thermal switch and bracket away from pipe.
- 1 Place bracket and new switch against pipe at removal site.
- 2 Using bonding compound (MIL-S-11030), bond switch and bracket to inlet valve. Let compound dry until it hardens.
- 3 Install one wire to each thermal switch terminal. (Reversing wires does not matter.)
- 4 Solder two wires to thermal switch terminals.
- 5 Fill in all open areas with polyurethane foam.
- 6 Install bottom plate. Install 16 bottom plate mounting screws.

5-27. LOW TEMPERATURE THERMAL SWITCH REPLACEMENT (CONT)

- 7 Set water chiller on skid.
- 8 Add oil (para 3-1).

5-28. TRAILER MOUNTING KIT INSTALLATION

This task covers installation only.

INITIAL SETUP

Tools

Basic Field Maintenance Automotive
Maintenance and Repair Shop
Equipment, item 3, appendix B

Materials/Parts

Welding rods, item 16,
appendix E

Personnel Required

Four to lift water chiller.

NOTE

For this procedure, it is not necessary to remove the exhaust muffler and housing from the water chiller.

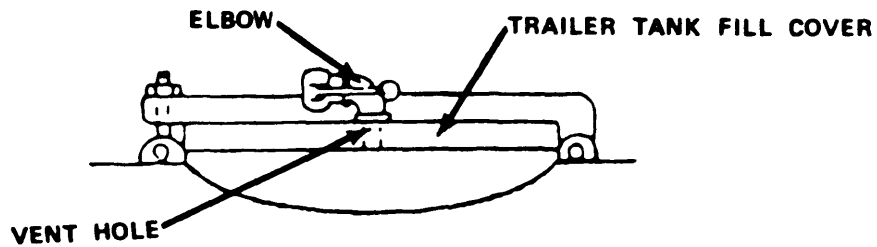

(LOCATED AT TOP OF TRAILER TANK)

- 1 Remove pipe plug from vent hole in trailer tank fill cover.
- 2 Install quick-disconnect elbow connection into vent hole in trailer tank fill cover.

5-28. TRAILER MOUNTING KIT INSTALLATION (CONT)

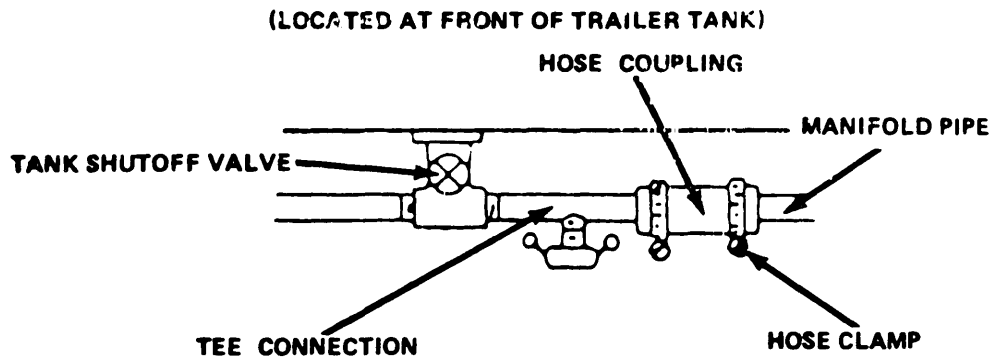

- 3 Loosen hose clamp on hose coupling from trailer tank manifold pipe.
- 4 Remove hose coupling from manifold pipe.
- 5 Remove pipe nipple from tank shutoff valve.
- 6 Install T-connection with quick-disconnect in tank shutoff valve.
- 7 Install new hose coupling and hose clamps between T-connection and manifold pipe.

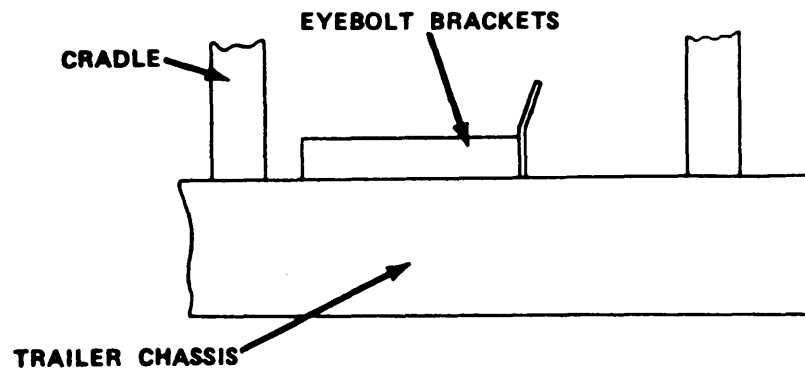

- 8 Place two eyebolt brackets on trailer chassis cross member approximately 8 in. (20 cm) inboard of outside member of trailer chassis.
- 9 Weld brackets in place.

5-28. TRAILER MOUNTING KIT INSTALLATION (CONT)

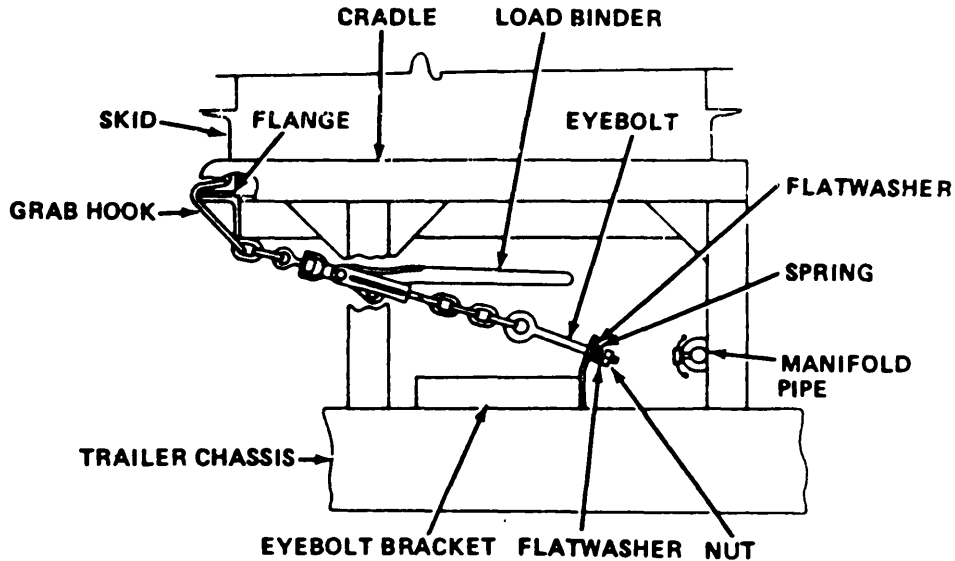

- 10 Place water chiller cradle on trailer chassis with rear legs of cradle placed firmly against the back side of the manifold pipe.
- 11 Weld water chiller cradle to trailer chassis.
- 12 Install eyebolts from end of load binders in eyebolt brackets.
- 13 Install two flatwashers, spring, and two nuts on each load binder eyebolt.

WARNING

To prevent injury, four persons are required for next step.

- 14 Using four people to lift, install water chiller in cradle with bottom of skid in lock position at rear of cradle.
- 15 Place grab hooks from load binders over flange of front skid and place load binder in lock position.

5-29. MODIFIED TRAILER MOUNTING KIT INSTALLATION

This task covers installation only.

INITIAL SETUP

Tools

Basic Field Maintenance Automotive
Maintenance and Repair Shop
Equipment, item 3, appendix B

Materials/Parts

Welding rods, item 16,
appendix E

Personnel Required

Four to lift water chiller.

NOTE

For this procedure, it is not necessary to remove the exhaust muffler and housing from the water chiller.

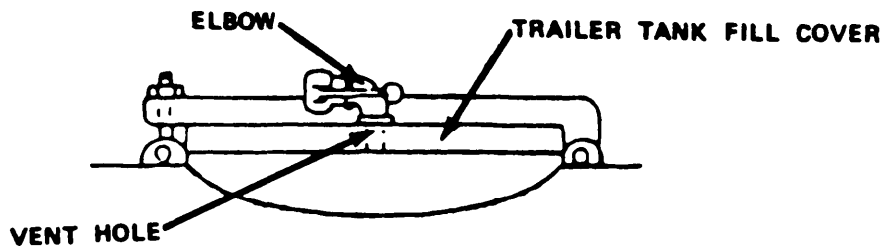

(LOCATED AT TOP OF TRAILER TANK)

- 1 Remove pipe plug from vent hole in trailer tank fill cover.
- 2 Install quick-disconnect elbow connection into vent hole in trailer tank fill cover.

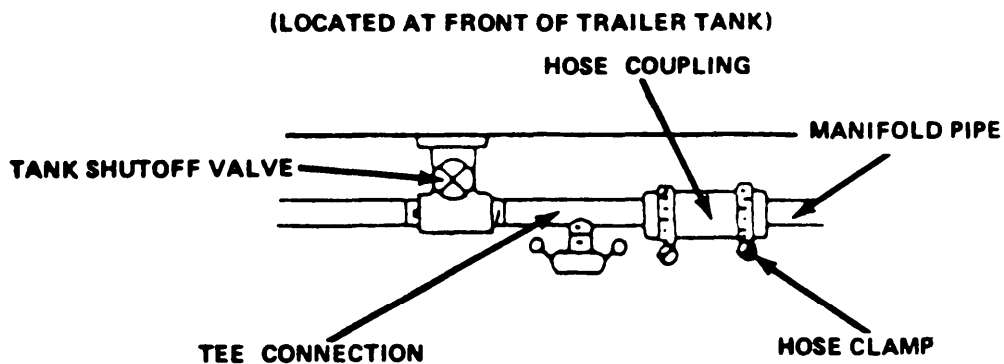

(LOCATED AT FRONT OF TRAILER TANK)

- 3 Loosen hose clamp on hose coupling from trailer tank manifold pipe.
- 4 Remove hose coupling from manifold pipe.
- 5 Remove pipe nipple from tank shutoff valve.

5-29. MODIFIED TRAILER MOUNTING KIT INSTALLATION (CONT)

- 6 Install T-connection with quick-disconnect in tank shutoff valve.
- 7 Install new hose coupling and hose clamps between T-connection and manifold pipe.

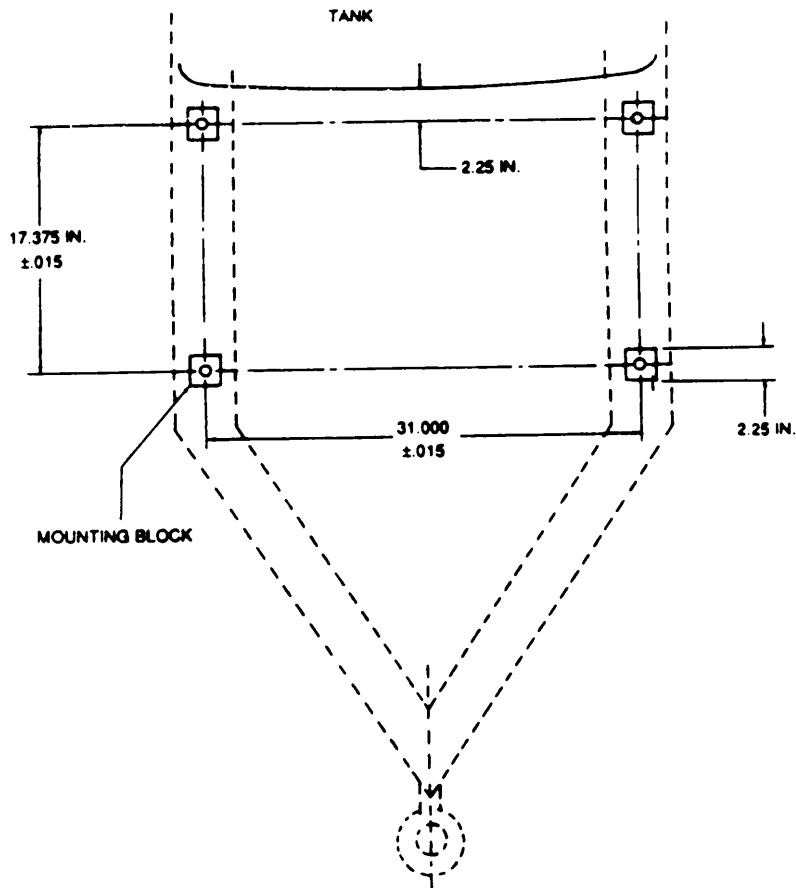

- 8 Remove cradle (4130-01-2567778) that is welded to trailer and grind area smooth if needed.

WARNING

To prevent personal injury, four persons are required to lift water chiller.

- 9 Attach mounting blocks to legs of cradle. Place water chiller in cradle and fasten with grab hooks. Using four people to lift, place water chiller on trailer and locate it approximately 1 inch from tank end. Weld mounting blocks to trailer when cradle is positioned properly.

**CHAPTER 6
GENERAL SUPPORT MAINTENANCE**

6-1. SCOPE. General support maintenance of the water chiller consists of repair or overhaul of the cylinder block assembly. Repair consists of replacement of defective parts. Overhaul consists of performing the entire disassembly, servicing, and assembly procedure.

6-2. CYLINDER BLOCK ASSEMBLY REPAIR/OVERHAUL

This task covers:

- a. Disassembly
- b. Servicing
- c. Assembly

INITIAL SETUP

Equipment Condition	<u>Para</u> <u>Condition</u> <u>Description</u>	Equipment Condition	<u>Para</u> <u>Condition</u> <u>Description</u>
	4-9 Housing removed.		4-22 Intake manifold assembly removed.
	4-19 Engine assembly removed.		4-21 Carburetor removed.
	4-15 Fan assembly removed.		5-5 Cylinder head assemblies removed,
	4-16 Pulley drive assembly removed water chiller, Model LCW-2685 only).		4-27 Starter removed.
	4-17 Centrifugal clutch removed (water chiller Model LCC-2685 only).		4-25 Armature group removed
	4-26 Dipstick and tube assembly removed.		4-28 Flywheel and ring gear assembly removed.
			4-18 Exhaust system removed.

Tools

Shop Equipment, Automotive
Maintenance and Repair: Field
Maintenance, Basic, item 3,
appendix B

Tools

Shop Equipment, Automotive
Maintenance and Repair: Field
Maintenance, Basic,
Supplement No. 2, item 6,
appendix B

6-2. CYLINDER BLOCK ASSEMBLY REPAIR/OVERHAUL (CONT)

Special Tools

Valve guide plug gage, pn 19151
Valve guide reamer, pn 19183
Reamer guide bushing, pn 19192

Personnel Required

Two to lift engine.

Materials/Parts

Engine oil, item 10, appendix E
Grease, item 8, appendix E
Kerosene, item 14, appendix E
Lapping compound, item 5, appendix E
Solvent, item 21, appendix E

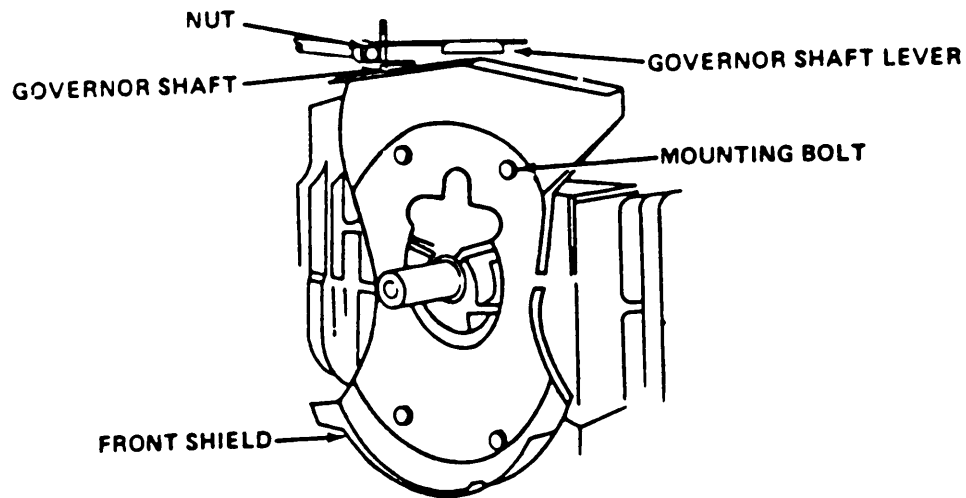

a. Disassembly

- 1 Remove governor shaft lever nut.
- 2 Remove governor shaft lever.

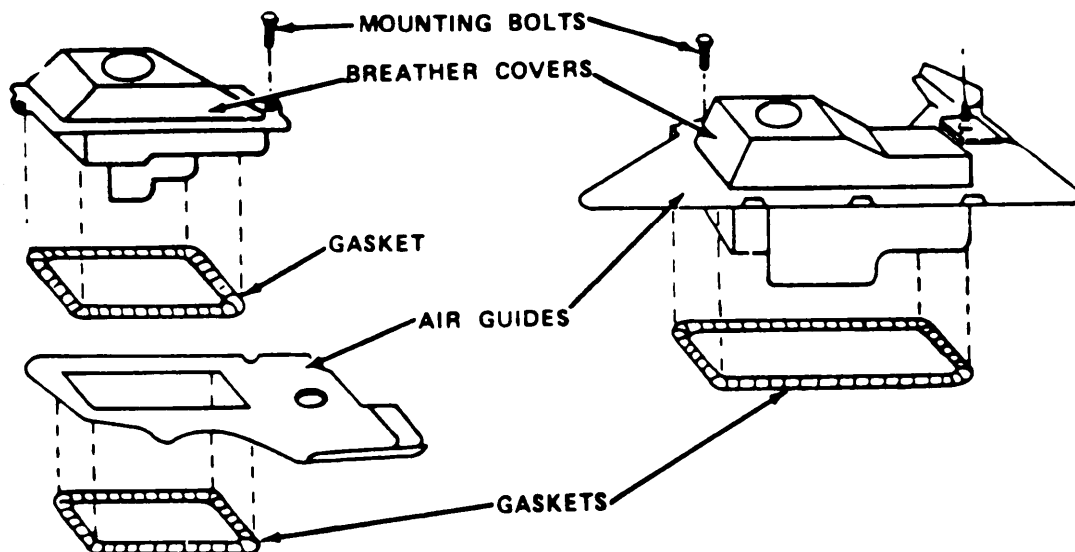

6-2. CYLINDER BLOCK ASSEMBLY REPAIR/OVERHAUL (CONT)

- 3 Remove two breather assembly mounting bolts from right cylinder. Remove breather cover, air guide, and gasket.
- 4 Remove two breather assembly mounting bolts from left cylinder. Remove breather cover, air guide, and two gaskets.

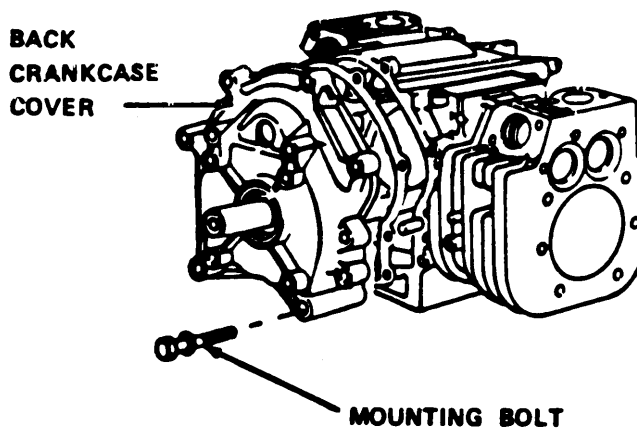

- 5 Remove seven back crankcase cover mounting bolts.
- 6 Tap gently on each side of back cover to loosen. Pull cover assembly off.

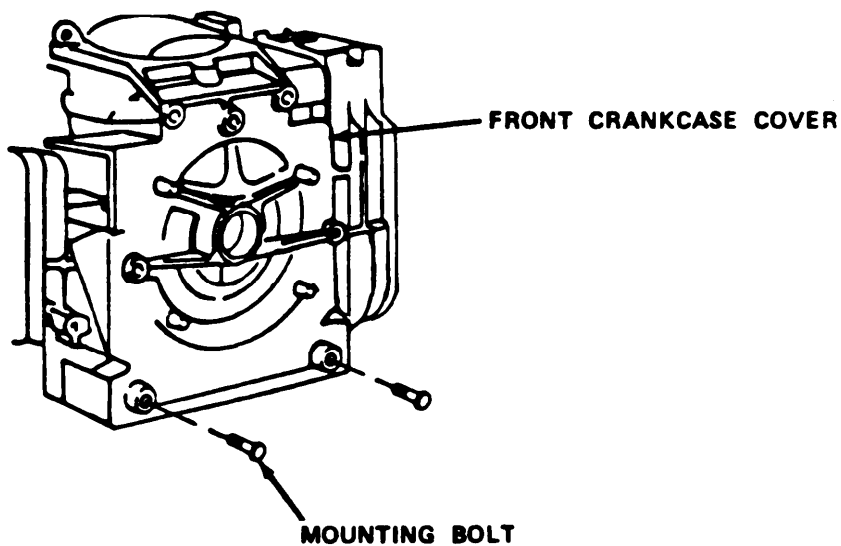

- 7 Remove seven front crankcase cover mounting bolts.
- 8 Tap gently on each side of front cover to loosen. Pull cover assembly off.

6-2. CYLINDER BLOCK ASSEMBLY REPAIR/OVERHAUL (CONT)

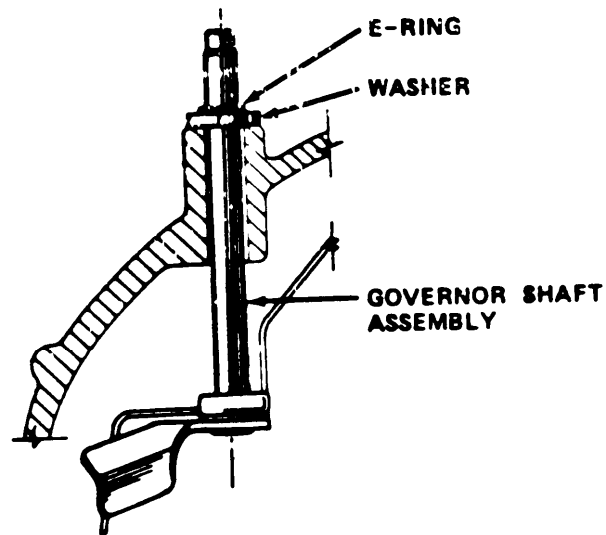

- 9 Remove governor shaft E-ring and washer. Remove governor shaft assembly.

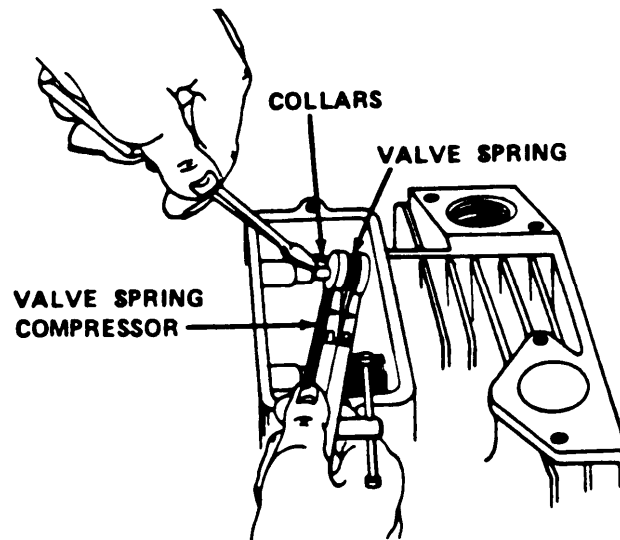

NOTE

DO NOT interchange parts when removing valves, valve springs, and tappets. Tappets must clear cam lobes before camgear can be removed.

- 10 Insert valve spring compressor tool in right breather opening.

6-2. CYLINDER BLOCK ASSEMBLY REPAIR/OVERHAUL (CONT)

- 11 Slip upper jaw between exhaust valve spring and exhaust valve chamber. Slip lower jaw between exhaust valve collars and exhaust valve spring.
- 12 Compress spring.

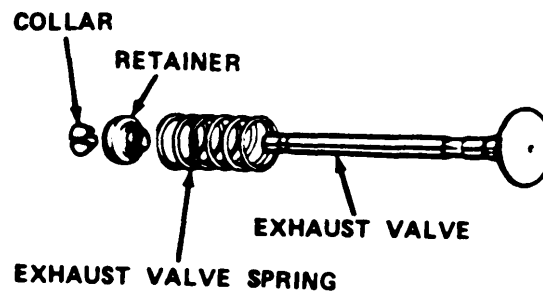

- 13 Pry collars from valve and remove.
- 14 Release spring tension and pull out exhaust valve. Remove exhaust valve spring.

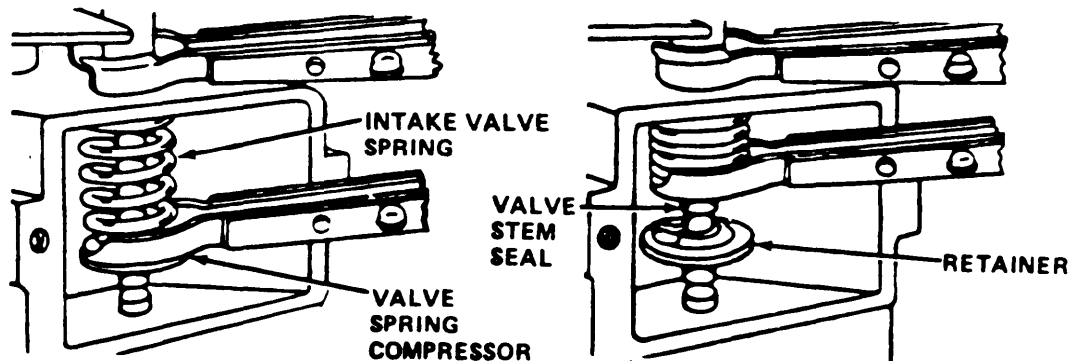

- 15 Slip upper jaw of valve spring compressor tool over valve chamber on intake valve side. Slip lower jaw between intake valve spring and intake valve retainer.
- 16 Compress spring and remove retainer.

6-2. CYLINDER BLOCK ASSEMBLY REPAIR/OVERHAUL (CONT)

CAUTION

Pull out intake valve slowly to prevent damaging seal.

NOTE

Apply engine oil to stem while pulling out valve.

- 17 Release spring tension; slowly pull out intake valve.
- 18 Remove valve stem seal, seal retainer, and compressor tool.
- 19 Repeat steps 10 through 18 for left breather opening.

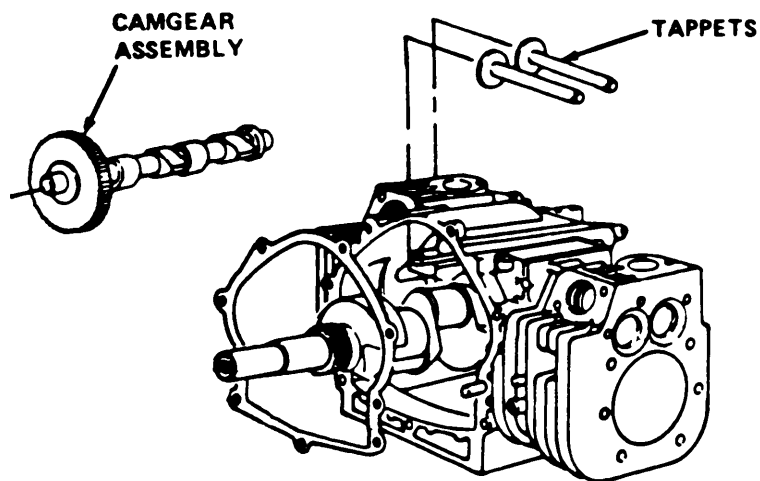

- 20 Remove camgear assembly. Remove four tappets.

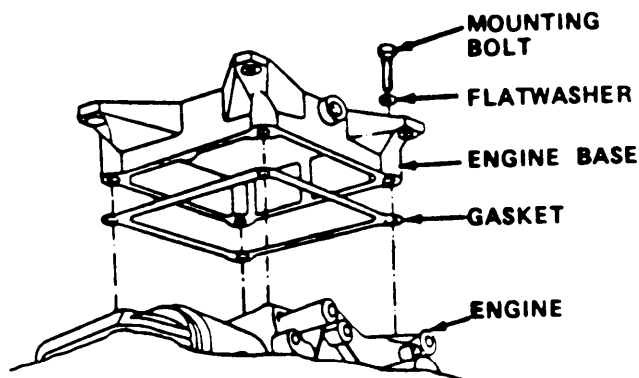

6-2. CYLINDER BLOCK ASSEMBLY REPAIR/OVERHAUL (CONT)**NOTE**

Two persons are required for next step.

- 21 Turn engine upside down. Remove four engine base mounting bolts, four flatwashers, and gasket.
- 22 Rotate crankshaft until right piston is at top dead center.

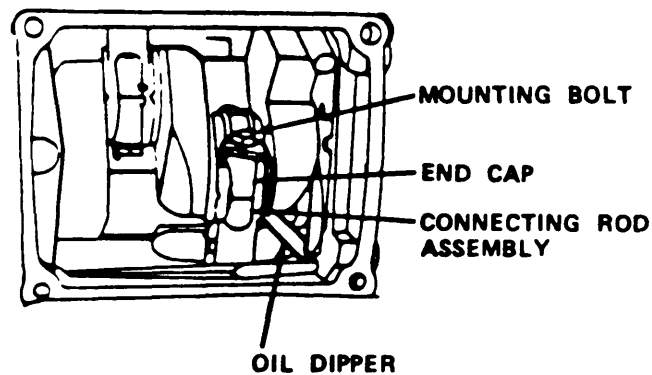
**NOTE**

DO NOT interchange parts when removing valves, valve springs, and tappets. Tappets must clear cam lobes before camgear can be removed.

- 23 Bend back tabs on connecting rod oil dipper.
- 24 Remove two end cap mounting bolts.
- 25 Pry off end cap.
- 26 Push piston and connecting rod assembly up through right cylinder assembly and set aside.
- 27 Repeat steps 22 through 26 for left cylinder assembly.

6-2* CYLINDER BLOCK ASSEMBLY REPAIR/OVERHAUL (CONT)

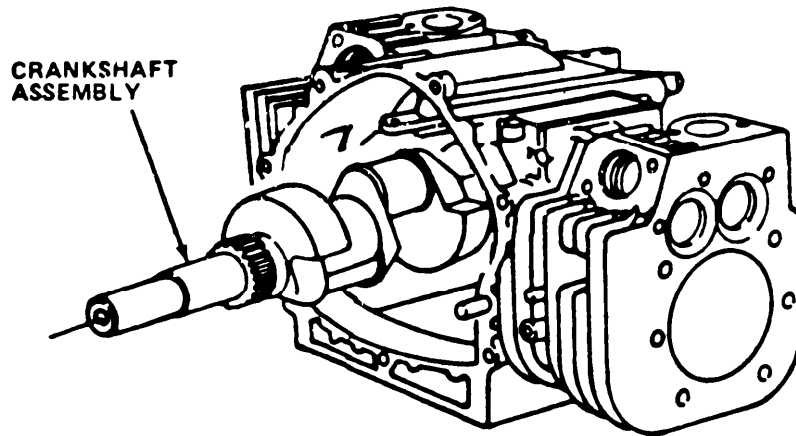

28 By hand, remove crankshaft assembly.

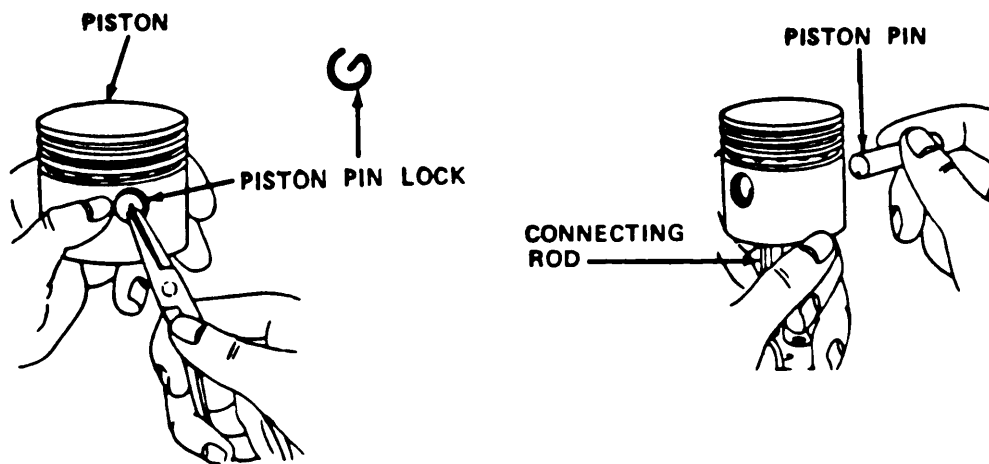

29 Obtain right connecting rod and piston assembly. Remove piston pin lock.

30 Pull out piston pin. Set connecting rod aside.

31 Remove second piston pin lock.

6-2. CYLINDER BLOCK ASSEMBLY REPAIR/OVERHAUL (CONT)

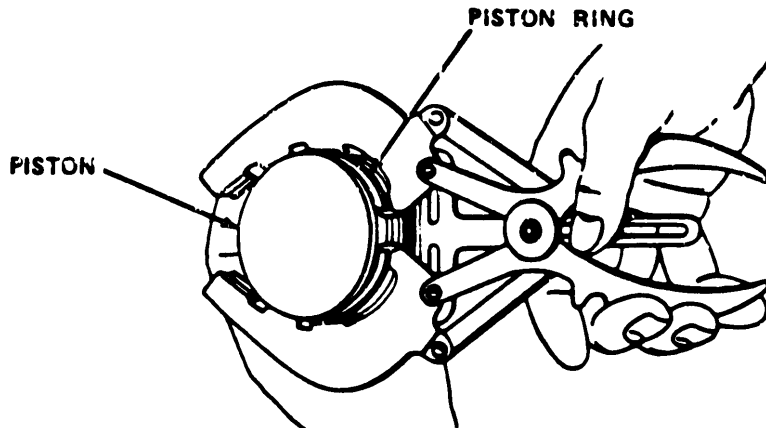

- 32 Remove piston rings one at a time. Set piston aside. Discard piston rings.
- 33 Repeat steps 29 through 32 for left connecting rod and piston assembly.

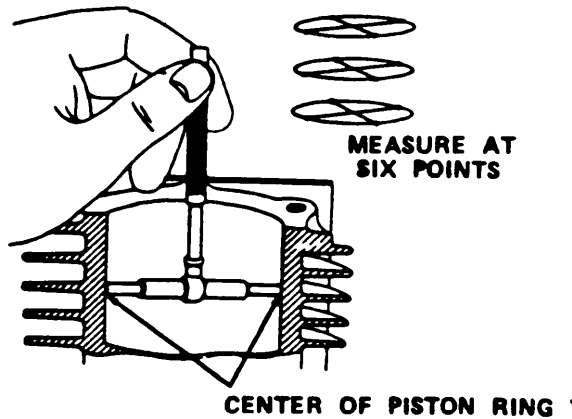

- 1 Visually inspect cylinders for cracked or scored walls.

NOTE

If cylinder bore is more than 0.003 in. (0.076 mm) oversize or more than 0.0025 in. (0.064 mm) out of round, cylinder block must be replaced.

- 2 Measure size of cylinder bore.

6-2. CYLINDER BLOCK ASSEMBLY REPAIR/OVERHAUL (CONT)

WARNING

- Solvent may cause toxic fumes. To prevent personal injury, work only in well-ventilated area. DO NOT breathe fumes for a long time.
 - Solvent is flammable. To prevent fire or explosion, DO NOT bring open flame or sparks near solvent.
- 3 Using solvent, clean cylinders to remove carbon buildup or foreign matter.
 - 4 Using solvent, clean carbon buildup from piston and grooves.

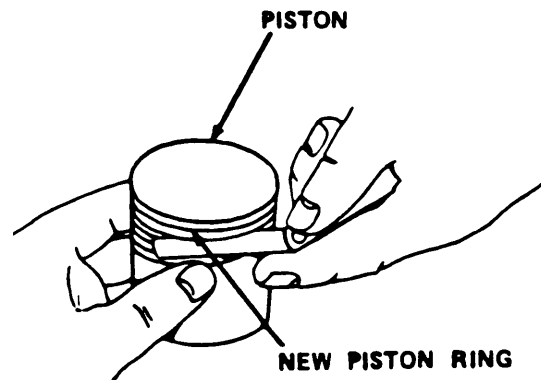

- 5 Install new piston ring on top ring groove of piston.
- 6 Check remaining space in groove. If space is 0.007 in. (0.18mm) or greater, remove piston ring and replace piston.
- 7 Repeat steps 4 through 6 for left cylinder.

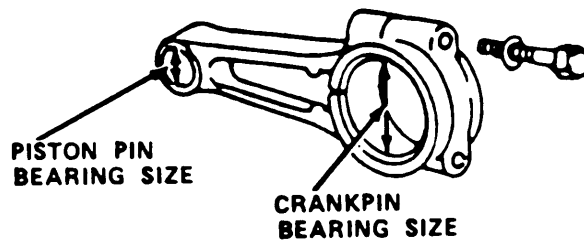

6-2. CYLINDER BLOCK ASSEMBLY REPAIR/OVERHAUL (CONT)

- 8 Obtain right connecting rod assembly. Check crankpin bearing size. If greater than 1.627 in. (41.33 mm), discard connecting rod assembly.
- 9 Check piston pin bearing size. If greater than 0.803 in.(20.40 mm), discard connecting rod assembly.
- 10 Repeat steps 8 and 9 with left connecting rod.

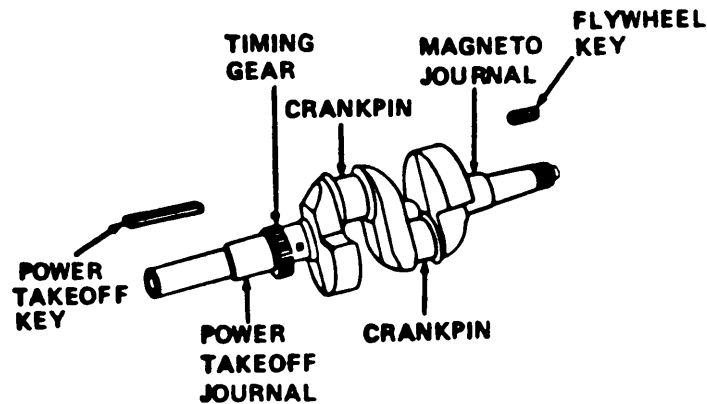
**NOTE**

Flywheel key and power takeoff key are NOT interchangeable.

- 11 Obtain crankshaft. Remove flywheel key and power takeoff key.
- 12 Remove timing gear from crankshaft.
- 13 Remove keyway from power takeoff journal on crankshaft.
- 14 Check timing gear for broken or missing teeth. Replace if needed.
- 15 Check crankshaft keyways to make sure they are not worn or spread. If worn or spread so key does not fit replace crankshaft.
- 16 Check the following points on the crankshaft: magneto journal, power takeoff journal, and crankpins.

6-2. CYLINDER BLOCK ASSEMBLY REPAIR/OVERHAUL (CONT)

17 Replace crankshaft under any of the following conditions:

- Power takeoff journal is less than 1.376 in. (34.95mm).
- Magneto journal is less than 1.376 in. (34.95 mm).
- Crankpins are less than 1.622 in. (41.20 mm).

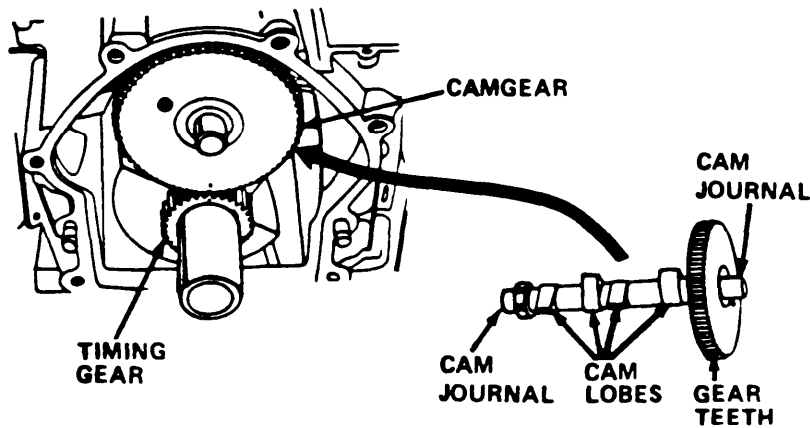

18 Obtain camgear. Check teeth on gear for nicks, wear, or breakage. If teeth are broken, nicked, or badly worn, replace camgear.

19 Check camgear lobes and cam journals. If camgear lobes are less than 1.124 in. (28.55 mm), replace camgear. If cam journals are less than 0.623 in. (15.82 mm), replace camgear.

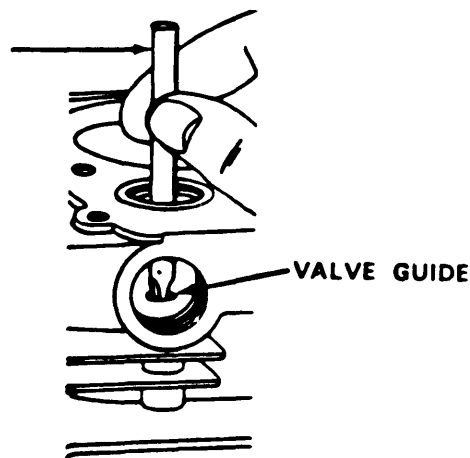

6 2. CYLINDER BLOCK ASSEMBLY REPAIR/OVERHAUL (CONT)

- 20 Check valve guides with valve guide plug gage. If valve guide plug gage can be inserted into the valve guide for a distance of 5/16 in. (8 mm), the guide is worn. Rebush guide by following steps 21 through 24.

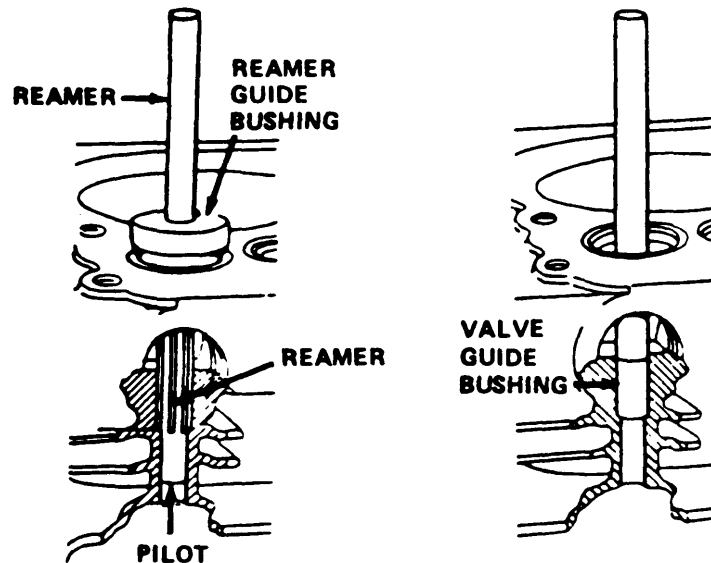

CAUTION

Ream to only 1/16 in. (1.6 mm) deeper than valve guide bushing 230655.
DO NOT ream through the guide.

- 21 Using reamer and reamer guide bushing, ream out the worn guide.

WARNING

Kerosene is flammable. To prevent fire or explosion, DO NOT bring open flame or sparks near kerosene.

- 22 Lubricate reamer as necessary with kerosene.
23 Press in valve guide bushing until top end of bushing is flush with top end of valve guide.

6-2. **CYLINDER BLOCK ASSEMBLY REPAIR/OVERHAUL (CONT)**

NOTE

Bushing is reamed to size at the factory and can be used with a standard valve.

- 24 Clean engine of any reaming debris and other foreign matter.

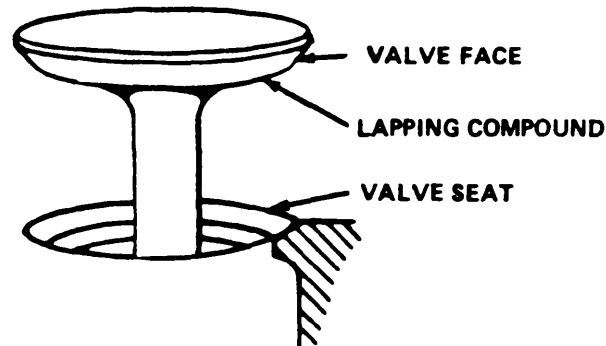

- 25 Obtain exhaust valves and intake valves.
- 26 Spread fine lapping compound around all valve faces. Pull valves into valve seats very slowly, one valve at a time. Once each is fully seated, turn it slowly left to right until it makes several complete turns.
- 27 Push valve out of valve chamber.
- 28 Inspect valve seat to ensure valve face has seated uniformly in valve seat.
- 29 If valve or valve seat is worn beyond usable limits or uniform wear pattern is not present, replace valves and valve seats.

6-2. CYLINDER BLOCK ASSEMBLY REPAIR/OVERHAUL (CONT)

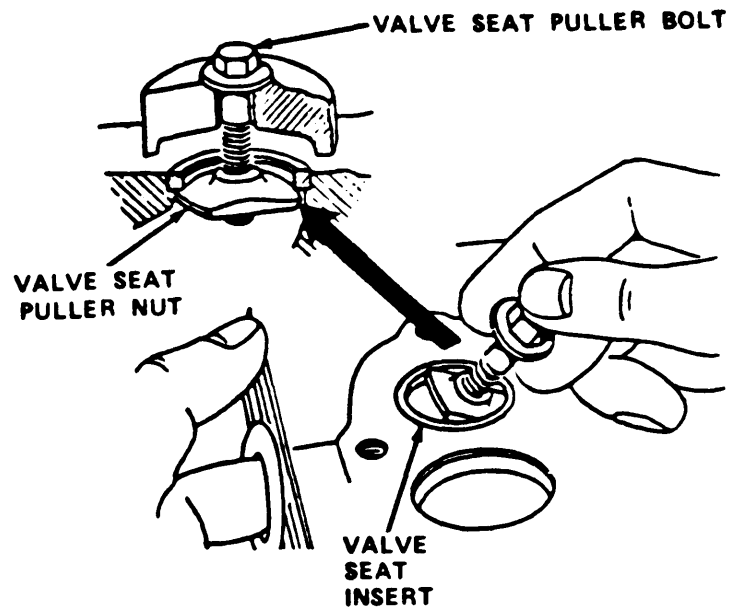

- 30 Position crankcase on left cylinder.
- 31 Insert valve seat puller nut through intake manifold opening so that it aligns with valve opening.
- 32 Screw valve seat puller bolt into puller nut.
- 33 Tighten valve seat puller bolt until puller nut seats against cylinder head.
- 34 Position valve seat puller so puller body does not rest on valve seat.
- 35 Tighten valve seat puller bolt until valve seat is pulled out of the cylinder.
- 36 Insert valve seat puller nut through exhaust manifold opening so it aligns with exhaust valve opening.
- 37 Screw valve seat puller bolt into puller nut.
- 38 Tighten valve seat puller bolt until puller nut seats against cylinder head.

6-2. CYLINDER BLOCK ASSEMBLY REPAIR/OVERHAUL (CONT)

- 39 Position valve seat puller so puller body does not rest on valve seat
- 40 Tighten valve seat puller bolt until valve seat is pulled out of cylinder.
- 41 Position crankcase on right cylinder.
- 42 Repeat steps 31 through 40 for left cylinder.

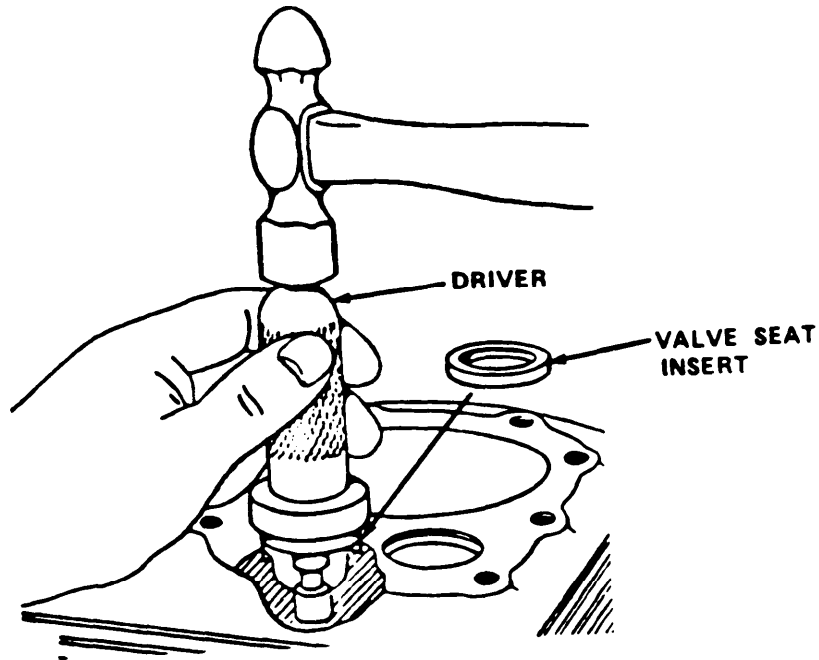

- 43 Place crankcase on left cylinder assembly.
- 44 Install new intake valve seat to right cylinder assembly.

NOTE

Make sure chamfered edge of valve seat goes down into cylinder.

- 45 Using driver, drive new seat until it bottoms. Seat will be slightly below cylinder head gasket surface.

6-2. CYLINDER BLOCK ASSEMBLY REPAIR/OVERHAUL (CONT)

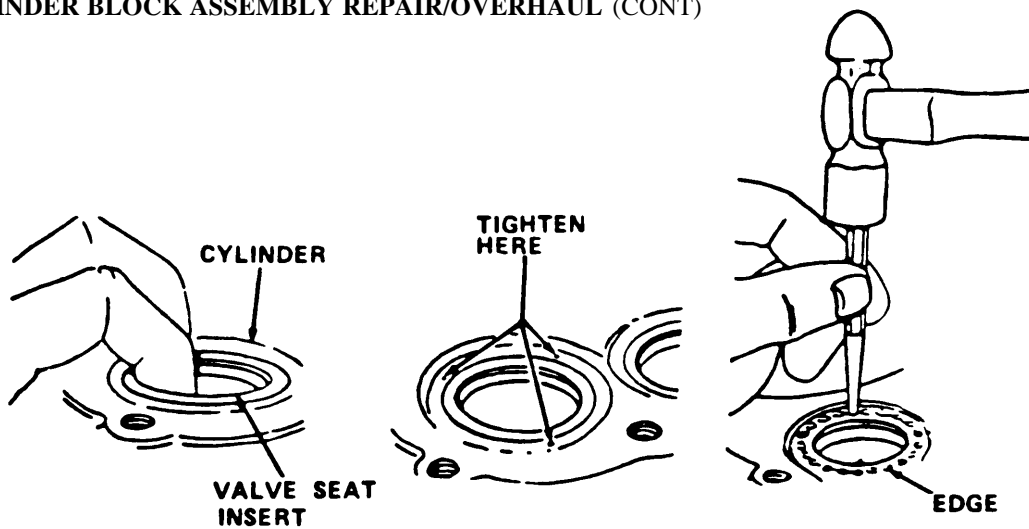

- 46 Check distance between valve seat and cylinder. If clearance exceeds 0.005 in. (0.13 mm), replace cylinder assembly.
- 47 Tighten valve seat by tapping seat at three equally spaced points.
- 48 Peen over edge around entire insert.
- 49 Repeat steps 44 through 48 for exhaust valve seat for right cylinder assembly.
- 50 Repeat steps 44 through 48 for intake valve seat for left cylinder assembly.
- 51 Repeat steps 44 through 48 for exhaust valve seat for left cylinder assembly.

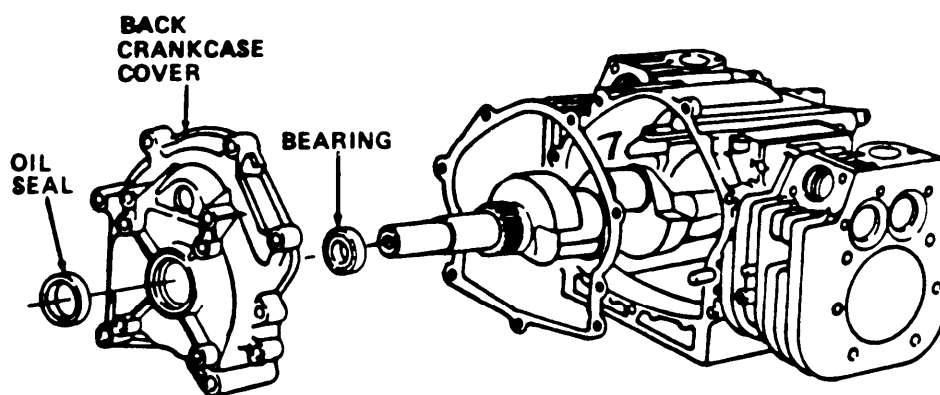

6-2. CYLINDER BLOCK ASSEMBLY REPAIR/OVERHAUL (CONT)

- 52 Pry oil seal from back crankcase cover.
- 53 Replace crankshaft bearing.
- 54 Install new oil seal to back crankcase cover. Press oil seal flush with flange.

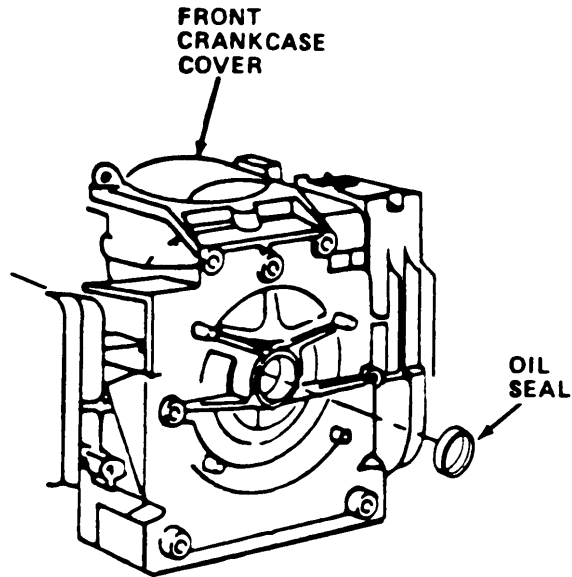

- 55 Pry oil seal from front crankcase cover.
- 56 Replace crankshaft bearing.
- 57 Install new oil seal to front crankcase cover. Press oil seal flush with flange.

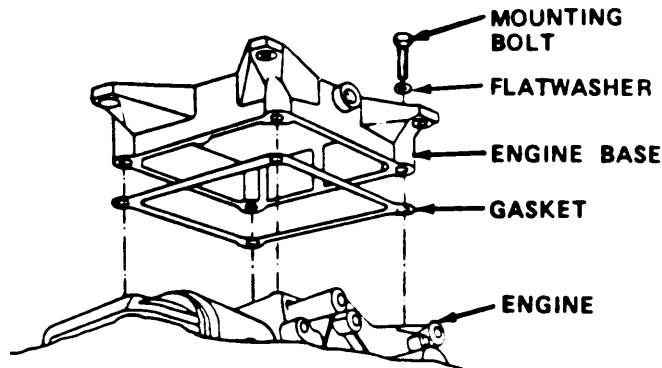

6-2. CYLINDER BLOCK ASSEMBLY REPAIR/OVERHAUL (CONT)

c. Assembly

- 1 With engine cylinder assembly upside down, install engine base gasket and engine base.
- 2 Install four engine base mounting bolts and flatwashers.

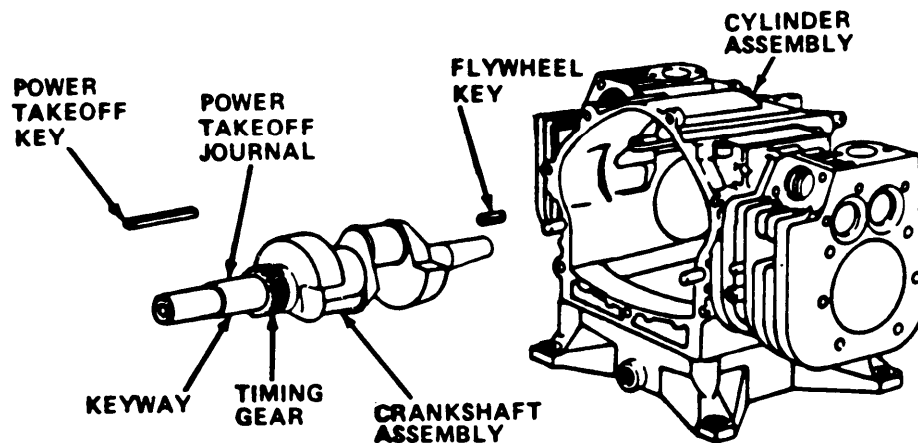

- 3 Turn engine cylinder assembly upright.
- 4 Install keyway to power takeoff journal on crankshaft
- 5 Slide timing gear onto power takeoff journal.
- 6 Tap timing gear gently until it fully seats.
- 7 Install flywheel key and power takeoff key on crankshaft.
- 8 Install crankshaft in engine cylinder assembly.

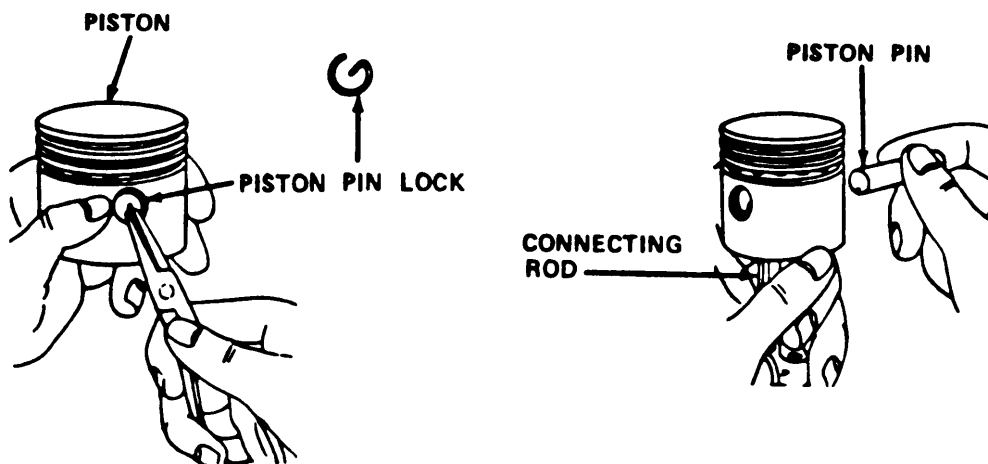

6-2. CYLINDER BLOCK ASSEMBLY REPAIR/OVERHAUL (CONT)

- 9 Install one piston pin lock in each piston assembly.
- 10 Place connecting rod assemblies up into pistons and make sure piston pin holes are alined. Make sure oil holes in connecting rods are facing camgear.
- 11 Install piston pins through pistons and connecting rod assemblies.
- 12 Install remaining piston pin locks in two piston assemblies.
- 13 Using engine oil (MIL-L-4152), lubricate piston rings and piston skirts.
- 14 Install rings on piston. Stagger ring gaps.

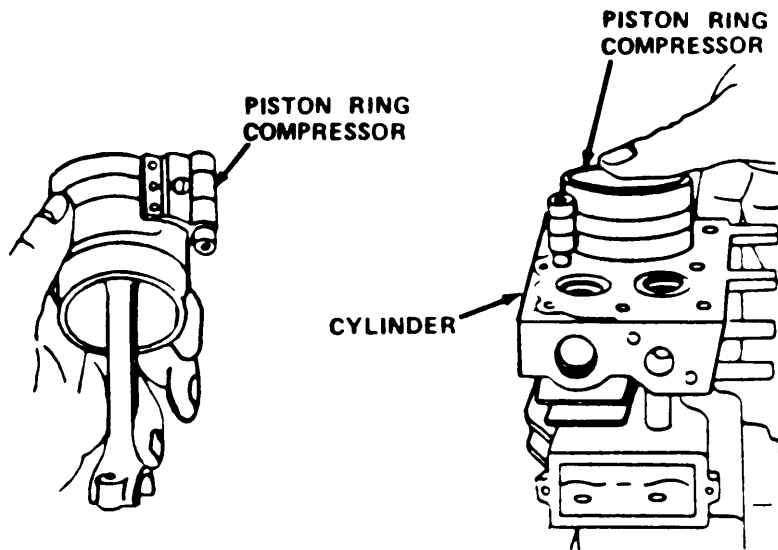

- 15 Tightly compress piston rings, then loosen compressor very slightly.

CAUTION

To prevent damage to piston rings, DO NOT try to install piston and ring gear assembly without ring compressor.

NOTE

- Notch on top of piston must face flywheel side of cylinder when installed.
- Do not interchange parts.

6-2. CYLINDER BLOCK ASSEMBLY REPAIR/OVERHAUL (CONT)

- 16 Push right piston and connecting rod assembly into right cylinder.

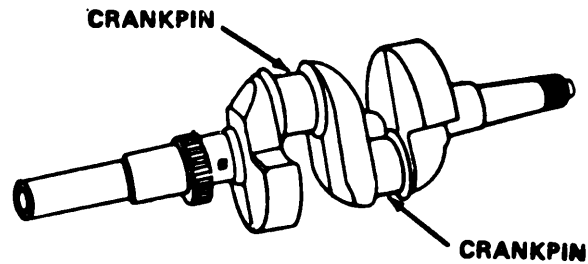

- 17 Using engine oil (MIL-L-46152), lubricate crankpin.

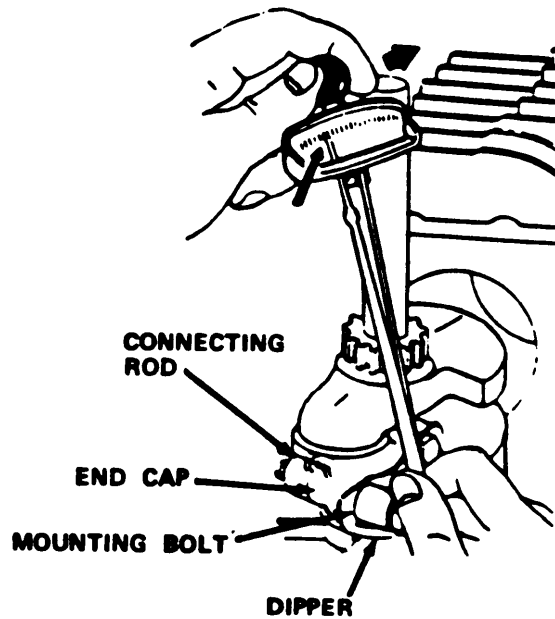

- 18 Pull connecting rod against crankpin and place end cap with dipper around crankpin. Make sure assembly marks on connecting rod and end cap are aligned.
- 19 Install end cap mounting bolts and torque to 190 in. lb (22Nm).
- 20 Bend tabs on dipper back around mounting bolts.

6-2. CYLINDER BLOCK ASSEMBLY REPAIR/OVERHAUL (CONT)

- 21 Rotate crankshaft to allow full entry of piston and connecting rod assembly.
- 22 Repeat steps 16 through 21 for left piston.

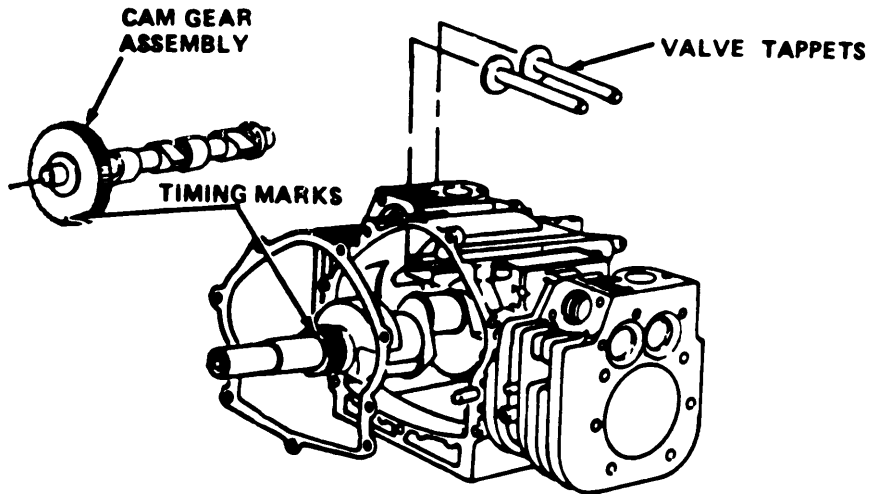

- 23 Making sure timing marks are aligned, install camgear assembly.

NOTE

Do not interchange parts.

- 24 Install four valve tappets.

6-2. CYLINDER BLOCK ASSEMBLY REPAIR/OVERHAUL (CONT)

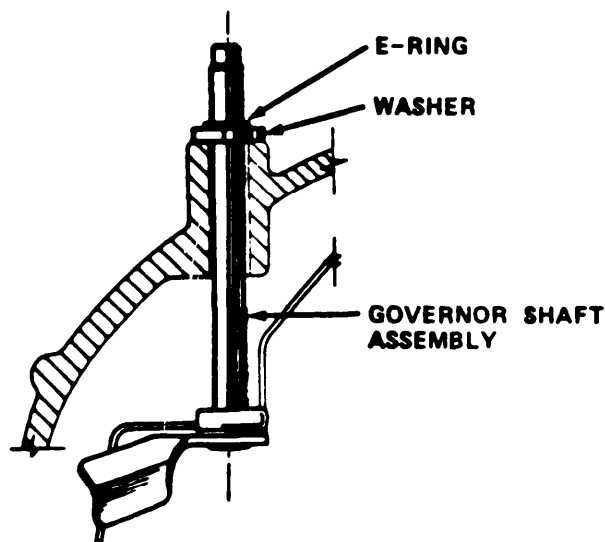

- 25 Install governor shaft assembly. Install washer and E-ring on governor shaft.

CAUTION

To prevent damage to oil seal while assembling crankcase cover, be sure to use oil or grease on sealing edge of oil seal. If sharp edge of oil seal is cut or bent under, seal may leak.

NOTE

New gasket sets include three crankcase cover or sump gaskets: 0.005, 0.009, and 0.015 in. (0.13, 0.23, and 0.38 mm) thick. Crankshaft end play should be 0.002 to 0.008 in. (0.05 to 0.20 mm) with one 0.015 in. (0.38 mm) gasket in place. If end play is less than 0.002 in. (0.05 mm), extra gaskets may be added in various combinations to attain the proper end play.

- 26 Apply a thin coating of oil or grease to sealing edge of oil seal. Wrap piece of thin paper around crankshaft so that seal will slide easily over shoulder of crankshaft.
- 27 Install new back crankcase cover gasket. Install back crankcase cover.

6-2. CYLINDER BLOCK ASSEMBLY REPAIR/OVERHAUL (CONT)

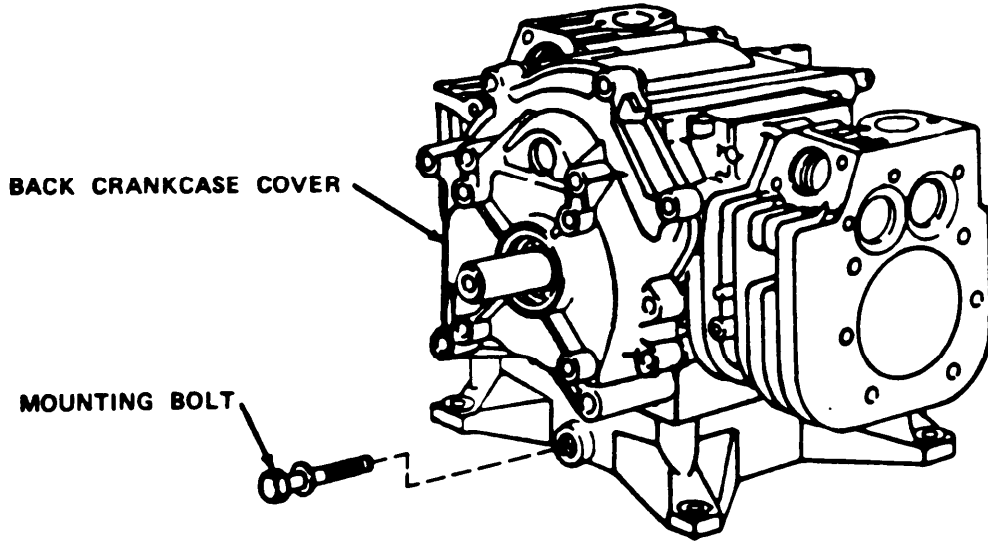

28 Install seven back crankcase cover mounting bolt.s.

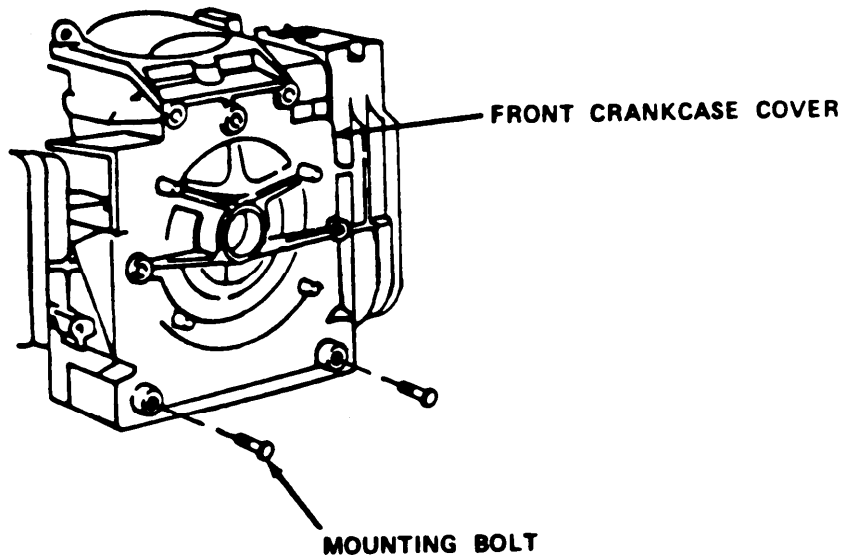

29 Install new front crankcase cover gasket. Install front crankcase cover.

30 Install seven front crankcase cover mounting bolts.

6-2. CYLINDER BLOCK ASSEMBLY REPAIR/OVERHAUL (CONT)

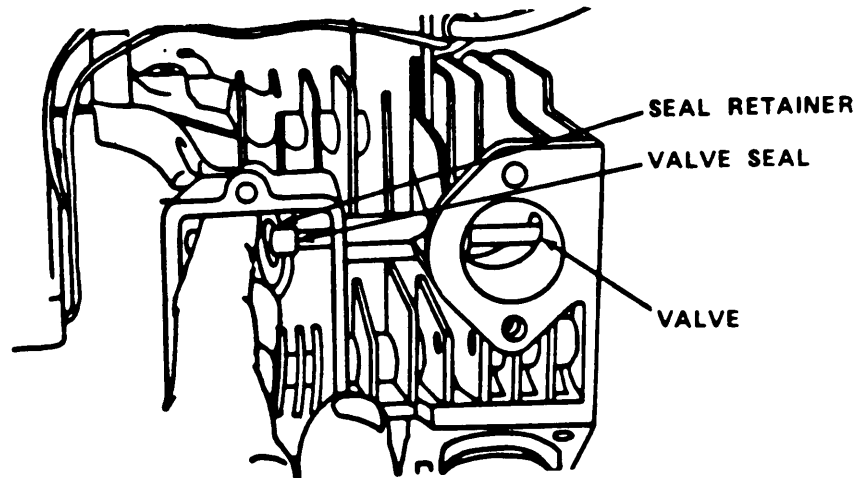

- 31 Place intake valve seal and seal retainer in right valve chamber.
- 32 Insert intake valve through guide while oiling guide lightly.
- 33 While rotating valve to prevent damage to seal, push valve slowly through seal and seal retainer.

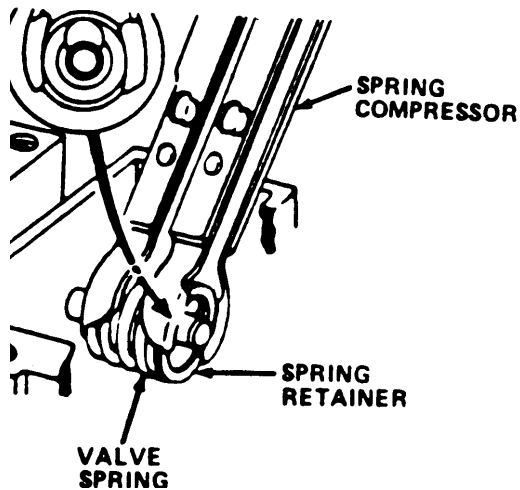

- 34 Place valve spring and spring retainer into spring compressor. Compressor spring.
- 35 Insert compressed spring and retainer into valve chamber with retainer facing back of chamber.

6-2. CYLINDER BLOCK ASSEMBLY REPAIR/OVERHAUL (CONT)

- 36 Open spring compressor about 3/8 to 1/2 in. (10 to 13 mm) while pushing valve all the way through spring retainer.
- 37 Snap retainer onto valve and release spring tension. Remove compressor from valve chamber.

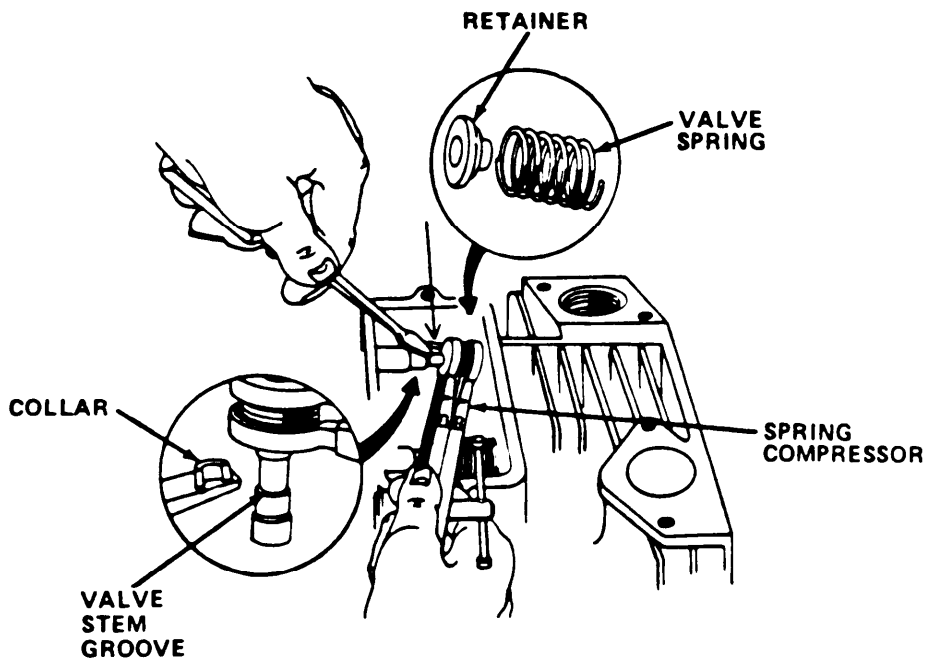

- 38 Insert exhaust valve spring and retainer into valve spring compressor. Compress valve spring.
- 39 Insert compressed spring and retainer into right valve chamber.
- 40 Push exhaust valve through retainer so it is fully seated.
- 41 Place collars into valve stem groove. Grase may be applied to collars and valve stem for ease in assembly.
- 42 Lower compressor tool so spring retainer fits over collars. Release spring tension and remove spring compressor.
- 43 Repeat steps 29 through 41 for left cylinder.

6-2* CYLINDER BLOCK ASSEMBLY REPAIR/OVERHAUL (CONT)

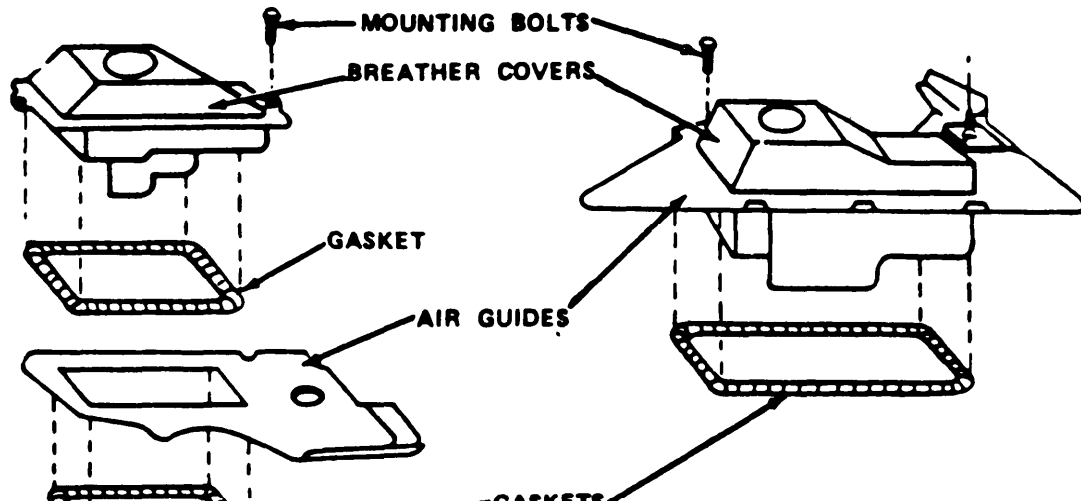

- 44 Assemble breather cover, gasket, and air guide. Install breather assembly and two breather assembly mounting bolts on right cylinder.
- 45 Assemble breather cover, two gaskets, and air guide. Install breather assembly and two breather assembly mounting bolts on left cylinder.

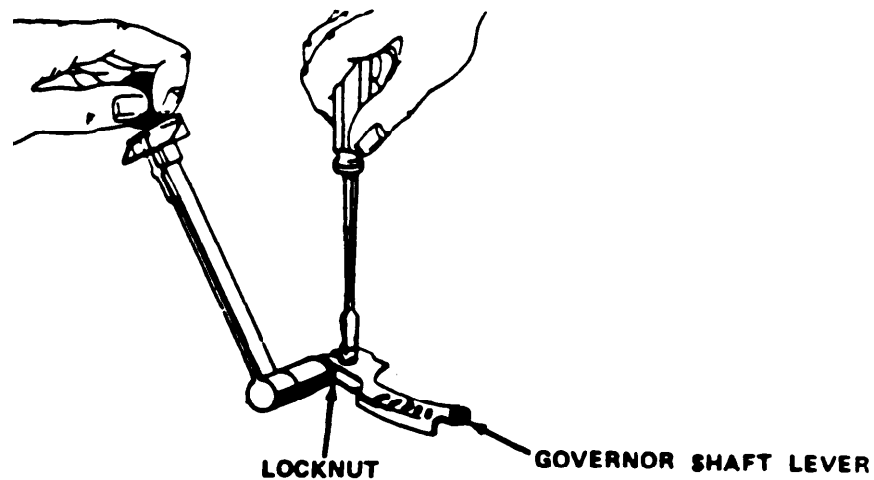

- 46 Install governor shaft lever. Rotate lever left direction as far as it will go. Hold lever in this position and rotate governor shaft left as far as it will go.

6-2. CYLINDER BLOCK ASSEMBLY REPAIR/OVERHAUL (CONT)

- 47 Install governor lever locknut. Torque locknut to 100 in. lb (11.3Nm).
- 48 Install exhaust system (para 4-18).
- 49 Install flywheel and ring gear assembly (para 4-28). DO NOT reinstall blower housing.
- 50 Install armature group (para 4-25). DO NOT install blower housing.
- 51 Install starter (para 4-27).
- 52 Install cylinder head assemblies (para 5-5).
- 53 Install intake manifold assembly (para 4-22).
- 54 Install carburetor assembly (para 4-21).
- 55 Install dipstick and tube assembly (para 4-26).
- 56 Install pulley drive assembly (applicable to water chiller, Model LCW-2685) (para 4-16).
- 57 Install centrifugal clutch (applicable to water chiller, Model LCC-2685) (para 4-17).
- 58 Install fan assembly (para 4-15).
- 59 Install engine assembly (para 4-19).
- 60 Install housing (para 4-9),

**APPENDIX A
REFERENCES**

A-1. SCOPE. This appendix lists all forms, field manuals, technical manuals, and other publications referenced in this manual.

A-2. FORMS

Equipment Inspection and Maintenance Worksheet	DA Form 2404
Quality Deficiency Report	SF 368
Recommended Changes to Publications and Blank Forms	DA Form 2028
Recommended Changes to Equipment Technical Publications	DA Form 2028-2

A-3. FIELD MANUALS

First Aid for Soldiers	FM 21-11
----------------------------------	----------

A-4. TECHNICAL MANUALS

Procedures for Destruction of Equipment to Prevent Enemy Use	TM 750-244-3
Small Mobile Water Chiller Repair Parts and Special Tools List (RPSTL)	TM 10413 O-237-24P

A-5. MISCELLANEOUS PUBLICATIONS

The Army Maintenance Management System (TAMMS)	DA Pam 738-750
--	----------------

APPENDIX B
MAINTENANCE ALLOCATION CHART

Section I. INTRODUCTION

B-1. GENERAL

- a. This section provides a general explanation of all maintenance and repair functions authorized at various maintenance categories.
- b. The Maintenance Allocation Chart (MAC) in section II designates overall authority and responsibility for the performance of maintenance functions on the identified end item or component.
- c. Section III lists the tools and test equipment (both special tools and common tool sets) required for each maintenance function as referenced from section II.
- d. Section IV contains supplemental instructions and explanatory notes for a particular maintenance function.

B-2. MAINTENANCE FUNCTIONS. Maintenance functions will be limited to and defined as follows:

- a. Inspect. To determine the serviceability of an item by comparing its physical, mechanical, and/or electrical characteristics with established standards through examination (e.g., by sight, sound, or feel).
- b. Test. To verify serviceability by measuring the mechanical, pneumatic, hydraulic, or electrical characteristics of an item and comparing those characteristics with prescribed standards.
- c. Service. Operations required periodically to keep an item in proper operating condition, i.e., to clean (includes decontaminate, when required), to preserve, to drain, to paint or to replenish fuel, lubricants, chemical fluids, or gases.
- d. Adjust. To maintain or regulate, within prescribed limits, by bringing into proper or exact position, or by setting the operating characteristics to specified parameters.
- e. Aline. To adjust specified variable elements of an item to bring about optimum or desired performance.

B-2. MAINTENANCE FUNCTIONS (CONT)

f. Calibrate. To determine and cause corrections to be made or to be readjusted on instruments or test, measuring, and diagnostic equipments used in precision measurement. Consists of comparisons of two instruments, one of which is a certified standard of known accuracy, to detect, and adjust, any discrepancy in the accuracy of the instrument being compared.

g. Remove/Install. To remove and install the same item when required to perform service or other maintenance functions. Install may be the act of emplacing, seating, or fixing into position a spare, repair part, or module (component or assembly) in a manner to (allow the proper functioning of an equipment or system.

h. Replace. To remove an unserviceable item and install a serviceable counterpart in its place. "Replace" is authorized by the MAC and is shown as the third position code of the SMR code.

i. Repair. The application of maintenance services¹, including fault location/troubleshooting², removal/installation, and disassembly/assembly³ procedures, and maintenance actions to identify troubles and restore serviceability to an item by correcting specific damage, fault, malfunction, or failure in a part, subassembly, module (component or assembly), end item, or system.

j. Overhaul. That maintenance effort (service/action) prescribed to restore an item to a completely serviceable/operational condition as required by maintenance standards in appropriate technical publications (i.e, DMWR). Overhaul is normally the highest degree of maintenance performed by the Army. Overhaul does not normally return an item to like-new condition.

¹Services – inspect, test, service, adjust, align, calibrate, and/or replace.

²Fault locate/troubleshoot – the process of investigating and detecting the cause of equipment malfunctioning; the act of isolating a fault within a system or unit under test (UUT).

³Disassemble/assemble – encompasses the step-by-step taking apart (or breakdown) of a spare/functional group coded item to the level of its least component identified as maintenance significant (i.e., assigned an SMR code) for the category of maintenance under consideration.

⁴Actions – welding, grinding, riveting, straightening, facing, remachining, and/or resurfacing.

B-2. MAINTENANCE FUNCTIONS (CONT)

k. Rebuild. Consists of those services/actions necessary for the restoration of unserviceable equipment to alike new condition in accordance with original manufacturing standards. Rebuild is the highest degree of maintenance performed by the Army. The rebuild operation includes the act of returning to zero those age measurements (hours/miles, etc.) considered in classifying Army equipment/components.

B-3. EXPLANATION OF COLUMNS IN THE MAC, SECTION II

a. Column 1. Group Number. Column 1 lists functional group code numbers, the purpose of which is to identify maintenance significant components, assemblies, subassemblies, and modules with the next higher assembly. End item group number shall be "00."

b. Column 2. Component/Assembly. Column 2 contains the names of components, assemblies, subassemblies, and modules for which maintenance is authorized

c. Column 3. Maintenance Function. Column 3 lists the functions to be performed on the item listed in column 2. (For detailed explanation of these functions, see paragraph B-2.)

d. Column 4. Maintenance Category. Column 4 specifies, by listing of a work time figure in the appropriate sub-column(s), the category of maintenance authorized to perform the function listed in column 3. This figure represents the active time required to perform that maintenance function to the indicated category of maintenance. If the number or complexity of the tasks within the listed maintenance function vary at different maintenance categories, appropriate work time figures will be shown for each category. The work time figure represents the average time required to restore an item (assembly, subassembly, component, module, end item, or system) to a serviceable condition under typical field operating conditions. This time includes preparation time (including any necessary disassembly/assembly time), troubleshooting/fault location time, and quality assurance/quality control time in addition to the time required to perform the specific task identified for the maintenance functions authorized in the maintenance allocation chart.

B-3. EXPLANATION OF COLUMNS IN THE MAC, SECTION II (CONT)

The symbol designations for various maintenance categories are as follows:

C	Operator or crew
O	Unit maintenance
F	Direct support maintenance
H	General support maintenance
L	Specialized repair activity (SRA) ⁵
D	Depot maintenance

e. Column 5. Tools and Equipment. Column 5 specifies, by code, those common tool sets (not individual tools) and special tools, TMDE, and support equipment required to perform the designated function.

f. Column 6. Remarks. This column shall, when applicable, contain a letter code, in alphabetic order, which shall be keyed to the remarks contained in section IV.

B-4. EXPLANATION OF COLUMNS IN TOOL AND TEST EQUIPMENT REQUIREMENTS, SECTION III

a. Column 1. Reference Code. The tool and test equipment reference code correlates with a code used in the MAC, section II, column 5.

b. Column 2. Maintenance Category. The lowest category of maintenance authorized to use the tool or test equipment.

c. Column 3. Nomenclature. Name or identification of the tool or test equipment.

d. Column 4. National Stock Number. The National stock number of the tool or test equipment.

e. Column 5. Tool Number. The manufacturer's part number.

⁵This maintenance category is not included in section II, column (4) of the maintenance allocation chart. To identify functions to this category of maintenance, enter a work time figure in the "H column of section II, column (4), and use an associated reference code in the Remarks column (6). Key the code to section IV, Remarks, and explain the SRA complete repair application there. The explanatory remark(s) shall reference the specific repair parts and special tools list (RPSTL) TM which contains additional SRA criteria and the authorized spare/repair parts.

B-5. EXPLANATION OF COLUMNS IN REMARKS, SECTION IV

- a. Column 1. Reference Code. The code recorded in column 6, section IL
- b. Column 2. Remarks. This column lists information pertinent to the maintenance function being performed as indicated in the MAC, section II.

**Section II. MAINTENANCE ALLOCATION CHART
FOR
SMALL MOBILE WATER CHILLER**

(1) GROUP NUMBER	(2) COMPONENT/ ASSEMBLY	(3) MAINTENANCE FUNCTION	(4) MAINTENANCE CATEGORY					(5) TOOLS AND EQUIPMENT	(6) REMARKS
			C	O	F	H	D		
00	Small Mobile Water Chiller								
01	Housing Assembly	Inspect Replace Repair	0.1	0.3 1.0				1 A	
02	Electrical System Wiring Harness	Inspect Test Repair	0.1	1.0 2.0				2 1 D E	
03	Drive System Drivebelts	Inspect Adjust Replace	0.1	0.5 1.0				1 1 F	
	Fan Assembly	Inspect Replace	0.1	1.5				1	
	Pulley Drive	Inspect Replace Repair		0.5 1.5 2.0				1 1 A	
	Centrifugal Clutch	Inspect Replace	0.1	1.8				9 A	
04	Exhaust System	Inspect Replace Repair	0.1	1.0 1.5				2 2 A	
04	Engine Assembly	Test Replace		1.0 2.0				2 1 O	
	Air Cleaner Cartridge and Precleaner	Inspect Service Replace	0.1 0.5	0.3				1 K H	

Section II. MAINTENANCE ALLOCATION CHART
FOR
SMALL MOBILE WATER CHILLER (CONT)

(1) GROUP NUMBER	(2) COMPONENT/ASSEMBLY	(3) MAINTENANCE FUNCTION	(4) MAINTENANCE CATEGORY					(5) TOOLS AND EQPT.	(6) REMARKS
			C	O	F	H	D		
	Carburetor Assembly	Inspect		0.2	0.2			1	
		Adjust		0.7				1	I
		Replace		1.0				1	
		Repair			2.0			1	
	Panel Assembly, Starter	Test		0.7				2	D
		Replace		1.0				2	
		Repair		1.0				2	A
	Armature Group Magnetron Ignition	Inspect		0.7				1	
		Test		1.5				1	J
		Adjust		1.5				1	I
		Replace		1.5				2	
		Repair		2.0				2	A
	Dipstick and Tube Assembly	Inspect	0.1						
		Replace		0.5				1	
		Repair		1.0				1	A
	Starter Motor	Inspect		0.7					
		Test		0.5				2	J
		Replace		1.0				1	
		Repair			2.5			3, 4	A
	Flywheel and Ring Gear Assembly	Inspect		1.0				1	
		Replace		2.0				2	
		Repair		2.5				2	A
	Cylinder Block Assembly	Inspect			1.0				
		Replace			8.0			4	G
		Repair				10.0		3, 4	
		Overhaul				12.0		3, 6	

**Section II. MAINTENANCE ALLOCATION CHART
FOR
SMALL MOBILE WATER CHILLER (CONT)**

(1) GROUP NUMBER	(2) COMPONENT/ASSEMBLY	(3) MAINTENANCE FUNCTION	(4) MAINTENANCE CATEGORY					(5) TOOLS AND EQPT.	(6) REMARKS
			C	O	F	H	D		
06	Refrigeration System	Inspect	0.1					5	P
		Test			2.5			4, 5, 7	
		Service			3.0				
	Hose Assemblies	Inspect	0.1						B
		Replace			3.0			4	
	Pressure Switch Assemblies	Inspect	0.1						D B
		Test Replace		1.0	3.0			2 4	
Condenser Assembly	Inspect	0.1		0.5	6.0			5	C B
	Service Replace								
Expansion Valve	Test				1.0			5	B
	Replace				3.0			4	
Compressor Assembly	Inspect		0.7					4	B B
	Replace Repair			4.0 6.0				4 4	
07	Water System	Inspect		0.7					A
		Replace		1.5				1	
		Repair			3.5			3	
	Thermal Switch, High Temperature	Test		0.5					2
Replace			1.5						
Evaporator	Inspect			0.5				5	N N, B
	Replace			6.0					

**Section II. MAINTENANCE ALLOCATION CHART
FOR
SMALL MOBILE WATER CHILLER (CONT)**

(1) GROUP NUMBER	(2) COMPONENT/ASSEMBLY	(3) MAINTENANCE FUNCTION	(4) MAINTENANCE CATEGORY					(5) TOOLS AND EQPT.	(6) REMARKS
			C	O	F	H	D		
08	Relief Valve	Adjust		0.1				1	
		Replace			3.0			4	N, A
		Repair		1.5				1	
	Thermostatic Valve	Inspect			1.0			4	N
		Replace			4.0			4	N
		Repair			5.0			4	N, A
	Ball Valve Assembly	Inspect	0.1						
		Replace			4.0			4	N
	Thermal Switch, Low Temperature	Test		0.5				2	D
		Replace			3.0			4	N
08 Skid Assembly	Vehicle Receptacle Assembly	Inspect	0.1						
		Replace		1.0				1	
	Skid	Inspect	0.1						
09 Trailer Mounting Kit		Repair		1.5				1	A
		Inspect	0.2						
10 Support Kit		Install			2.0			3	M
		Repair		2.0				1	A
10 Support Kit		Inspect	0.2						L
		Repair		1.5				1	A

**Section III. TOOL AND TEST EQUIPMENT REQUIREMENTS
FOR
SMALL MOBILE WATER CHILLER**

(1) TOOL/TEST EQUIP. REF CODE	(2) MAINTENANCE CATEGORY	(3) NOMENCLATURE	(4) NATIONAL/NATO STOCK NUMBER	(5) TOOL NUMBER
1	O	Tool Kit, General Mechanic's Automotive	5180-00-177-7033	
2	O	Shop Equipment, Automotive Maintenance and Repair: Organizational Maintenance Common No. 1	4910-00-754-0654	
3	F, H	Shop Equipment, Automotive Maintenance and Repair: Field Maintenance, Basic	4910-00-754-0705	
4	F, H	Tool Kit, Master Mechanic's	5180-00-699-5273	
5	F	Tool Kit, Service, Refrigeration Unit	5180-00-596-1474	
6	H	Shop Equipment, Automotive Maintenance and Repair: Field Maintenance. Basic Supplement No. 2	4910-00-754-0707	
7	F	Vacuum Pump	4310-00-289-5967	
8	O	Soldering Gun Kit	3439-00-930-1638	
9	O	Puller Adapter (Appendix F)		
10	F, H	Recovery and Recycling Unit, Refrigerant	4130-01-338-2707	17500B (07295)

Section IV. REMARKS

REFERENCE CODE	REMARKS
A	Repair by replacing defective components.
B	After a component is replaced or system is opened, evacuate the system, replace the filter-drier, and recharge the system with R-12 refrigerant.
C	Clean condenser periodically to maintain airflow.
D	Test continuity.
E	Use bulk wire for harness repair.
F	Adjust belt tension.
G	If internal parts are defective, replace short block assembly and evacuate to higher level of maintenance for repair.
H	Replace element and cartridge.
I	Adjust to specification.
J	Check current flow.
K	Service by cleaning filters.
L	Upon receipt, conduct inventory of kit.
M	Weld mounting kit to trailer frame.
N	Remove and replace foam insulation.
O	Perform compression test.
P	Test refrigeration system for freon leaks.

APPENDIX C**COMPONENTS OF END ITEM AND BASIC ISSUE ITEMS LISTS****Section I. INTRODUCTION**

- C-1. SCOPE.** This appendix lists components of end item and basic issue items for the Small Mobile Water Chiller to help you inventory items required for safe and efficient operation.
- C-2. General.** The Components of End Item and Basic Issue Items Lists are divided into the following sections:
- a. Section II. Components of End Item. This listing is for informational purposes only, and is not authority to requisition replacements. These items are part of the end item, but are removed and separately packaged for transportation or shipment. As part of the end item, these items must be with the end item whenever it is issued or transferred between property accounts. Illustrations are furnished to assist you in identifying the items.
 - b. Section III. Basic Issue Items. These are the minimum essential items required to place the Small Mobile Water Chiller in operation, to operate it, and to perform emergency repairs. Although separately packaged, basic issue items (BII) must be with the Small Mobile Water Chiller during operation and whenever it is transferred between property accounts. The illustrations will assist you in hard-to-identify items. This manual is your authority to request/requisition replacement BII, based on TOE/MTOE authorization of the end item.
- C-3. EXPLANATION OF COLUMNS.** The following provides an explanation of columns found in the tabular listings:
- a. Column (1) - Illustration Number (Illus Number). This column indicates the number of the illustration in which the item is shown.
 - b. Column (2) - National Stock Number. Indicates the National stock number assigned to the item and will be used for requisitioning purposes.
 - c. Column (3) - Description. Indicates the Federal item name and, if required, a minimum description to identify and locate the item. The last line for each item indicates the CAGEC (in parentheses) followed by the part number.

C-3. EXPLANATION OF COLUMNS (CONT)

d. Column (4) - Unit of Measure (U/M). Indicates the measure used in performing the actual operational/maintenance function. This measure is expressed by a two-character alphabetical abbreviation (e.g., ea, in., pr).

e. Column (5) - Quantity required (Qty Rqr). Indicates the quantity of the item authorized to be used with/on the equipment.

Section II. COMPONENTS OF END ITEM

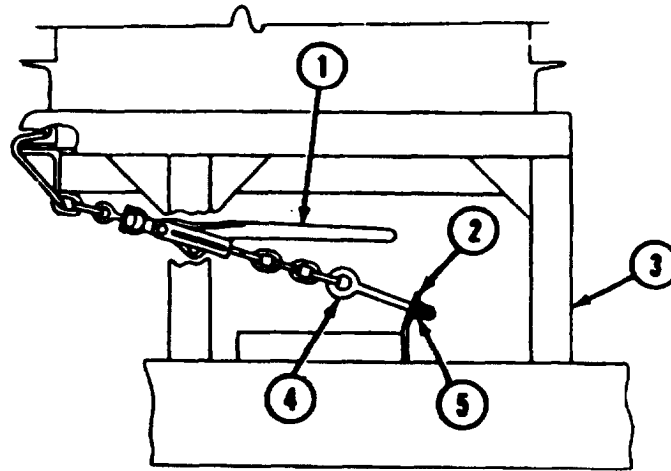

(1) Illus Number	(2) National Stock Number	(3) Description FSCM and Part Number	(4) U/M	(5) Qty Rqr
		MOUNTING KIT, TRAILER (97403) 13226E1712 Consists of the following:	EA	1
1		BINDER, LOAD (97403) 13226E1736	EA	2
2		BRACKET, EYEBOLT (97403) 13226E1721	EA	2
3		CRADLE, WATER CHILLER (97403) 13226E1727	EA	2
4		EYEBOLT (75535) G-291,3/8 x 4-1/2	EA	2
5		FLATWASHER MS15759-814	EA	2

Section II. COMPONENTS OF END ITEM (CONT)

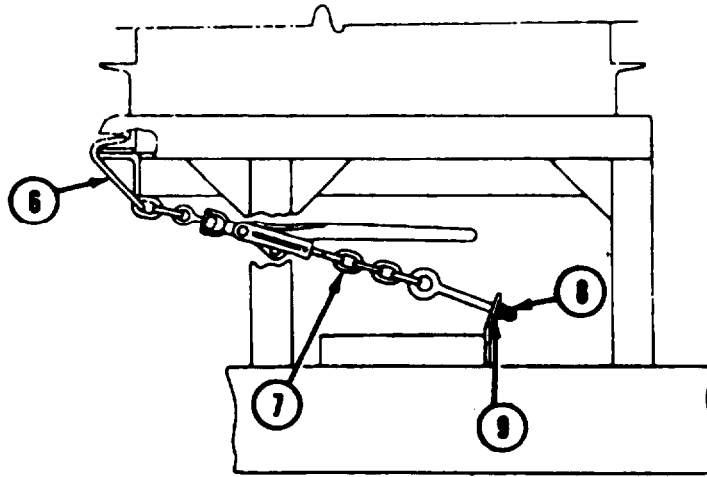

(1) Illus Number	(2) National Stock Number	(3) Description FSCM and Part Number	(4) U/M	(5) Qty Rqr
6		MOUNTING KIT TRAILER (MODIFIED) HOOK, GRAB (97403) 13226E1719	EA	2
7		LINK, CONNECTING (81346) RR-C-271, TYPE II	EA	12
8		NUT, HEXHEAD MS35649-2312	EA	2
9		SPRING, COMPRESSION (84830) LC-072H-4	EA	2

Section II. COMPONENTS OF END ITEM (CONT)

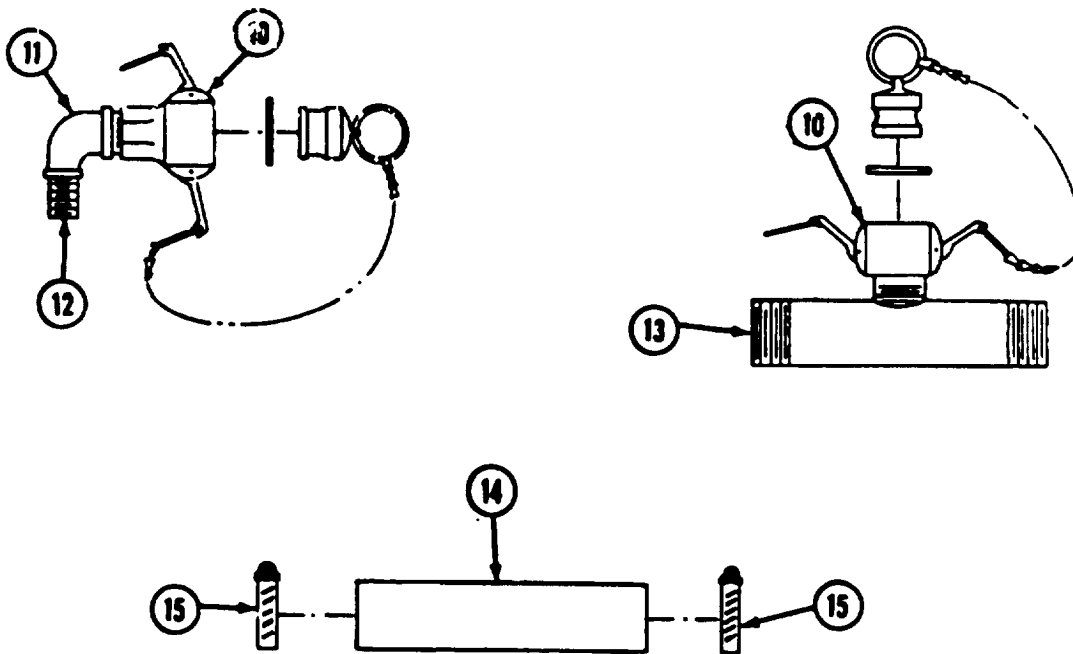

(1) Illus Number	(2) National Stock Number	(3) Description FSCM and Part Number	(4) U/M	(5) Qty Rqr
10		COUPLING HALF, FEMALE MS27026-3	EA	2
11		ELBOW, BRASS, REDUCING, 90° MS14308-4	EA	1
12		NIPPLE, REDUCER, BRASS, HEX SAEJ530, PN 130137	EA	1
13		NIPPLE (79403) A213226E1819	EA	1
14		HOSE, RUBBER (79403) A213226E1820	EA	1
15		CLAMP, HOSE MS35842-13	EA	2

Section II. COMPONENTS OF END ITEM (CONT)

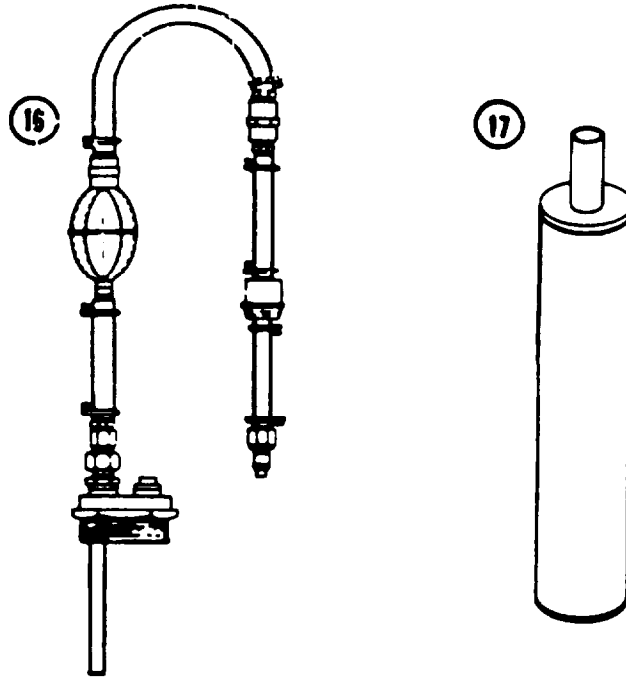

(1) Illus Number	(2) National Stock Number	(3) Description FSCM and Part Number	(4) U/M	(5) Qty Rqr
16		SUPPORT KIT, WATER CHILLER (97403) 13226E1790 Consists of the following:	EA	1
17		LINE, FUEL ASSEMBLY (97403) 13226E1714 MUFFLER (97403) 13226E1733	EA	1

Section II. COMPONENTS OF END ITEM (CONT)

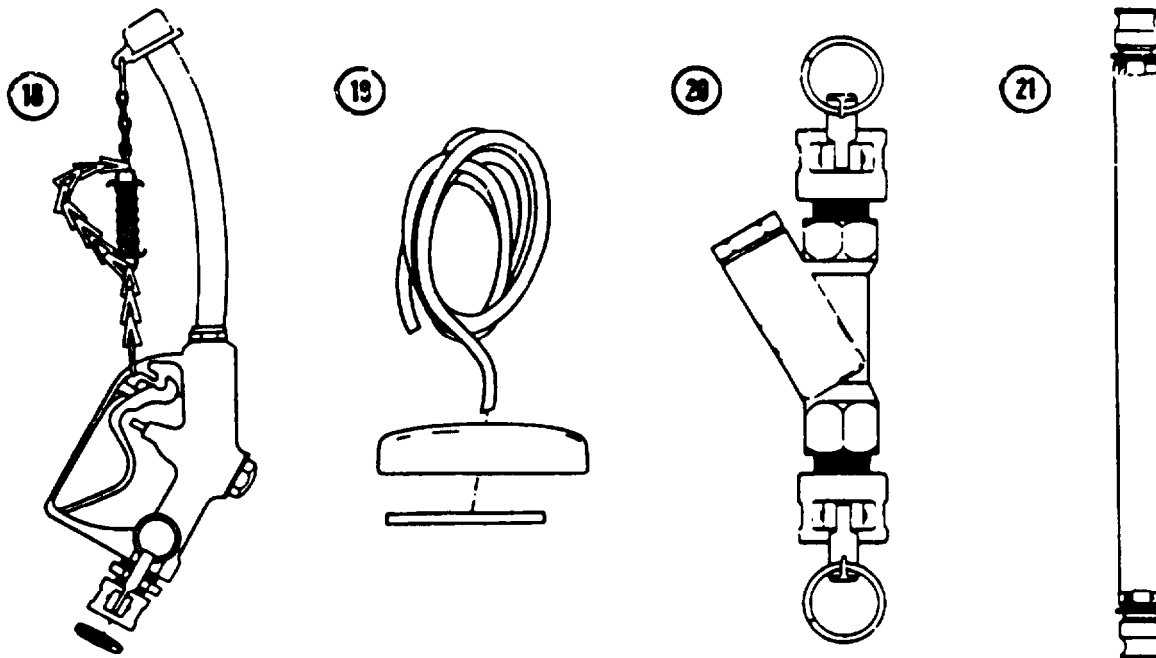

(1) Illus Number	(2) National Stock Number	(3) Description FSCM and Part Number	(4) U/M	(5) Qty Rqr
18		NOZZLE ASSEMBLY (97403) 1322681787	EA	1
19		ROPE, STARTER (97403) 13226E1796	EA	1
20		STRAINER ASSEMBLY (97403) 13226E1738		
21		TUBE ASSEMBLY 13226E1710	EA	5

Section III. BASIC ISSUE ITEMS

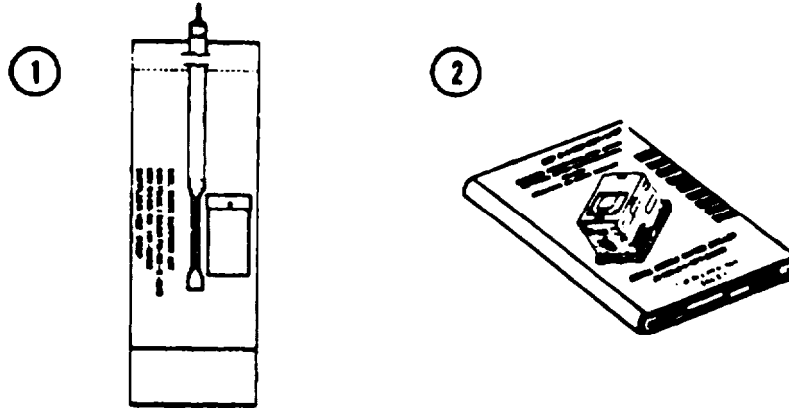

(1) Illus Number	(2) National Stock Number	(3) Description FSCM and Part Number	(4) U/M	(5) Qty Rqr
1	8465-00-141-0932	BAG. AUXILIARY STORAGE (97403) 13226E1802	EA	1
2		MANUAL, OPERATOR'S, ORGANIZATIONAL. DIRECT SUPPORT. AND GENERAL SUPPORT MAINTENANCE MANUAL, SMALL MOBILE WATER CHILLER. TM 10-4130-237-14	EA	1

**APPENDIX D
ADDITIONAL AUTHORIZATION LIST**

Section I. INTRODUCTION

D-1. SCOPE. This appendix lists additional items you are authorized for the support of the Small Mobile Water Chiller.

D-2. GENERAL. This list identifies items that do not have to accompany the Small Mobile Water Chiller and that do not have to be turned in with it. These items are all authorized to you by CTA, MTOE, TDA, or JTA.

D-3. EXPLANATION OF LISTING. National stock numbers, descriptions, and quantities are provided to help you identify and request the additional items you require to support this equipment. The items are listed in alphabetical sequence by item name under the type document (i.e., CTA, MTOE, TDA, or JTA) which authorizes the item to you.

Section II. ADDITIONAL AUTHORIZATION LIST

(1) National Stock Number	(2) Description FSCM and Pm Number	(3) U/M	(4) Qty Rqr
4910-00-387-9592	PADDLE, WOODEN	EA	1
	PAIL, UTILITY, 5-GALLON	EA	2
	PAIL, UTILITY, 1-GALLON	EA	1
	PAN, DRAIN, 4-GALLON	EA	1
	THERMOMETER	EA	1

APPENDIX E

EXPENDABLE/DURABLE SUPPLIES AND MATERIALS LIST

Section I. INTRODUCTION

E-1. SCOPE. This appendix lists expendable/durable supplies and materials you will need to operate and maintain the Small Mobile Water Chiller. This listing is for informational purposes only and is not authority to requisition the listed items. These items are authorized to you by CTA 50-970, Expendable/Durable Items (Except Medical, Class V, Repair Parts, and Heraldic Items), or CTA 8-100, Army Medical Department Expendable Durable Items.

E-2. EXPLANATION OF COLUMNS

a. Column (1) - Item Number. This number is assigned to the entry in the listing and is referenced in the narrative instructions to identify the material (e.g., "Use cleaning compound, item 5, Appendix D.").

b. Column (2) - Level. This column identifies the lowest level of maintenance that requires the listed item,

C - Operator/crew

O - Unit maintenance

F - Direct support maintenance

H - General support maintenance

c. Column (3) - National Stock Number. This is the National stock number assigned to the item; use it to request or requisition the item.

d. Column (4) - Description. Indicates the Federal item name and, if required, a description to identify the item.

e. Column (5) - Unit of Measure (U/M). Indicates the measure used in performing the actual maintenance function. This measure is expressed by a two-character alphabetical abbreviation (e.g., ea, in., pr). If the unit of measure differs from the unit of issue, requisition the lowest unit of issue that will satisfy your requirements.

SECTION II. EXPENDABLE/DURABLE SUPPLIES AND MATERIAL LIST

(1) ITEM NUMBER	(2) LEVEL	(3) NATIONAL STOCK NUMBER	(4) DESCRIPTION	(5) U/M
1	O		ADHESIVE-SEALANT, SILICONE, RTV, NON-CORROSIVE, ML-A-16146, TYPE III	OZ
2	O		ANTIFREEZE, NONTOXIC PROPYLENE-GLYCOL, PN 13226E1839	GL
3	F		BRAZING ALLOY, SILVER, BCUP-5, QQ-B-654	AR
4	C		CALCIUM HYPOCHLORITE POWDER, 0-C-114	OZ
5	H		COMPOUND, LAPPING AND GRINDING, A-A-1203	OZ
6	C		DETERGENT, LIQUID	OZ
7	C	9130-00-160-1817	GASOLINE, MOGAS, TYPE 1. MIL-G-3056	GL
8	H	9150-00-935-1017	GREASE, AUTOMOTIVE AND ARTILLERY, MIL-G-10924	OZ
9	F	9150-00-058-2286	GREASE, NONTOXIC, GP, MINERAL OIL CALCIUM SOAP	OZ
10	C	9150-00-186-6705	OIL, LUBRICATING. OEHD, 15W-4., MIL-L-46152	QT
11	F		OIL, LUBRICATING, REFRIGERANT COMPRESSOR, VV-L-825	OZ
12	F	5350-00-264-3485	PAPER, ABRASIVE	SH
13	F	8135-00-130-9754	POLYURETHANE FOAM, FLEXIBLE, MIL-P-26514	OZ
14	H	9130-00-559-2475	PROPELLANT, KEROSENE, MIL-R-25576	CT
15	F		REFRIGERANT, FLUOROCARBON, TYPE 12, BB-F-1421	LB

Section II. EXPENDABLE/DURABLE SUPPLIES AND MATERIALS LIST (CONT)

(1) Item Number	(2) Level	(3) National Stock Number	(4) Description	(5) U/M
16	F	3439-00-244-4540	RODS, WELDING, QQ-R-571	EA
17	F	8040-00-024-6988	SEALING COMPOUND, NON-CURING, POLYSULFIDE BASE, MIL-S-11030	OZ
18	F	8030-00-081-2325	SEALING, LOCKING, AND RETAINING COMPOUNDS, SINGLE COMPONENT, MIL-S-22473	OZ
19	F		SOLDER, ACID CORE, SN96. WRAP 3, QQ-S-571	AR
20	O		SOLDER, ROSIN CORE, SN60, WRAP 2, QQ-S-571	AR
21	F	6850-00-664-5685	SOLVENT, DRY CLEANING, TYPE II FED-P-D-680	QT
22	O	9905-00-537-8954	TAGS, MARKING	EA
23	O	8030-00-889-3535	TAPE, ANTI SEIZE. TETRAFLUORO- ETHYLENE, MIL-T-27730	RO

APPENDIX F

ILLUSTRATED LIST OF MANUFACTURED ITEMS

F-1. SCOPE. This appendix includes complete instructions for making items authorized to be manufactured or fabricated at unit maintenance. A part number index in alphanumeric order is provided for cross-referencing the part number of the item to be manufactured to the figure which covers fabrication criteria. All bulk materials needed for manufacture of an item are listed by part number or specification number in a tabular list on the illustration.

MANUFACTURED ITEM	FIGURE NO.
MES-90-0001 DRIVE HUB ASSEMBLY ADAPTER	F-1

Drill two 1/2" holes for two jaw slide hammer/puller or three 1/2" holes spaced 120° apart for three jaw slide hammer/puller file holes as required to mate with puller jaws.

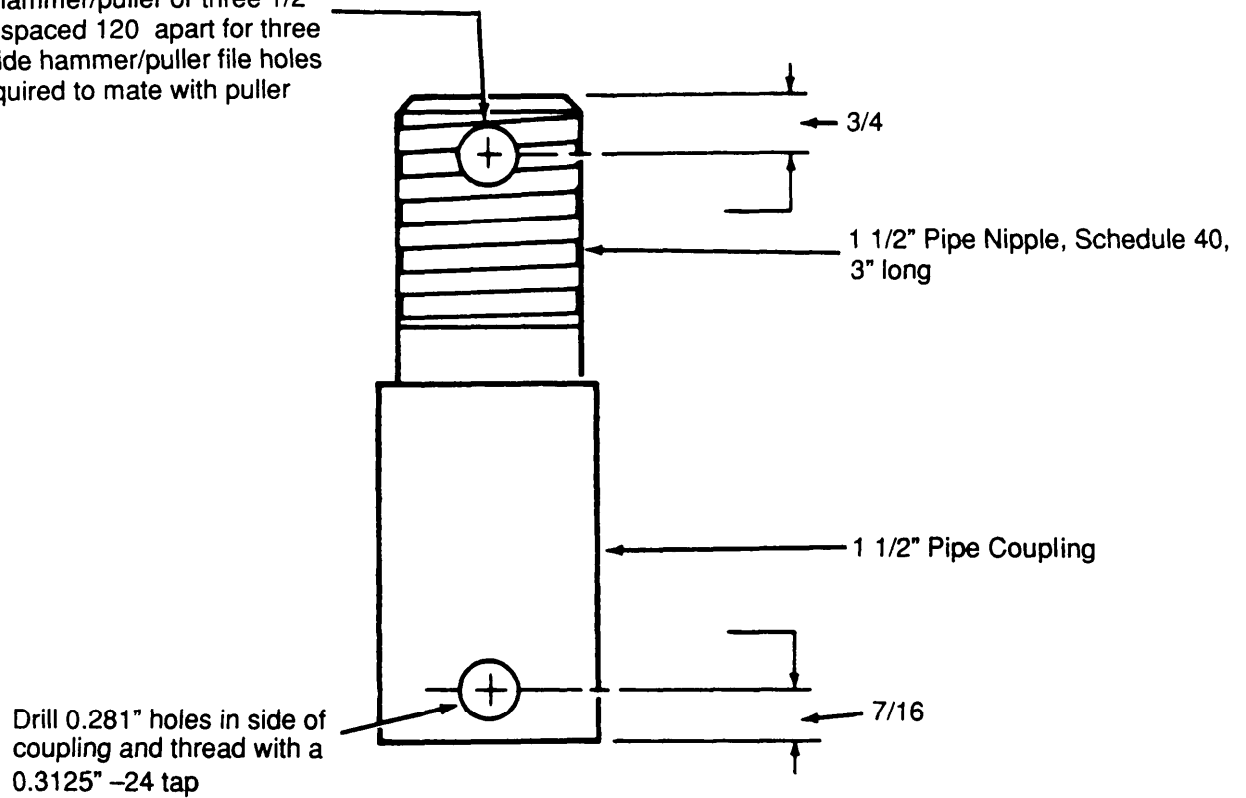

PULLER ADAPTER MES 90-0001

1. Connect predrilled pipe Coupling and pipe nipple.
2. Place puller adapter overdrive hub assembly and align 0.281" hole in adapter with hole in drive hub assembly.
3. Thread bolt through puller adapter into hole in drive hub assembly. Bolt should extend 1/2" to 3/4" into drive hub assembly.
4. Using a standard two or three jaw puller, remove drive hub assembly from shaft.

NOTES

1. Fabricate from:

- a. 1 1/2" pipe nipple, schedule 40, 3" long (39428) 4549K654 or equivalent
- b. 1 1/2" pipe coupling (39248) 4544K27
- c. Bolt, MS35308-338 (or equivalent)

2. All dimensions are in inches.

INDEX

SUBJECT	Page
A	
Additional authorization list	D-1
Adjustment procedures	
Armature group	4-61
Carburetor	4-47
Compressor drivebelt	4-24
Relief valve..	4-92
Sparkplugs	4-57
Water pump drivebelt	4-22
Armature group	
Adjustment	4-61
Assembly	4-65
Disassembly	4-63
Inspection	4-59
Repair	4-61
Replacement	4-61
Testing	4-60
Army Maintenance Management System (TAMMS), The	1-1
Assembly and preparation for use.	2-16
Assembly procedures	
Armature group	4-65
Carburetor	5-9
Cylinder block assembly	6-19
Flywheel and ring gear assembly	4-78
S t a r t e r	5-17
Thermostatic valve	5-80
Water pump	5-70
Automatic shutdown	2-26
B	
Ball valve	
Installation	5-82
Removal	5-81
Replacement	5-81

INDEX

SUBJECT	Page
C	
Carburetor	
Adjustment	4-47
Installation	4-42
Removal	4-41
Repair	5-4
Replacement	4-41
Carrying handles	
Installation	4-100
Removal	4-99
Centrifugal clutch replacement/repair	
Assembly	4-30
Disassembly	4-30
Checks and services, operator preventive maintenance	2-3
Checks and services, organizational preventive maintenance	4-4
Common tools and equipment	4-2
Components of end item and basic issue items lists	C-1
Compressor	
Installation	5-57
Removal	5-55
Repair	5-60
Replacement	5-55
Compressor cylinder head and valve plate	
Installation	5-61
Removal	5-60
Compressor discharge hose	
Installation	5-41
Removal	5-41
Replacement	5-40

INDEX

SUBJECT	Page
Compressor drivebelt	
Adjustment	4-23
Installation	4-24
Removal	4-23
Replacement	4-23
Compressor shaft seal	
Installation	5-43
Removal	5-63
Compressor suction hose	
Installation	5-39
Removal	5-39
Replacement	5-38
Condenser	
Installation	5-48
Removal	5-47
Replacement	5-47
Cylinder block assembly	
Installation	5-26
Removal	5-24
Replacement	5-23
Repair	6-1
Cylinder heads	
Installation	5-20
Removal	5-19
Replacement	5-19

D

DA Form 2404, Equipment Inspection and Maintenance Worksheet	2-4
DA Form 2028, Recommended Changes to Publications and Blank Forms	i

INDEX

SUBJECT	Page
DA Form 2028-2, Recommended Changes to Equipment Technical Publications	i
DA Pam 738-750, The Army Maintenance Management System (TAMMS)	1-1
Data, equipment	1-4
Decals and instruction plates, operating instructions on	2-29
Description and use of operator's controls and indicators	2-1
Destruction of Army materiel to prevent enemy use	1-1
Dimensions, equipment	1-4
Dipstick and tube assembly	
Installation	4-68
Removal	4-68
Repair	4-67
Replacement	4-67
Direct support maintenance	5-1
Direct support troubleshooting	5-1
Disassembly procedures	
Armature group	4-63
Carburetor	5-4
Cylinder block assembly	6-2
Flywheel and ring gear assembly	4-75
Pulley drive	4-26
Relief valve	4-90
Starter	5-14
Thermostatic valve	5-80
Water pump	5-68
Drivebelt, compressor	
Adjustment	4-24
Installation	4-24
Removal	4-23
Replacement	4-23

INDEX

SUBJECT	Page
Drivebelt, water pump	
Adjustment	4-22
Installation	4-22
Removal	4-22
Replacement	4-21
E	
Engine assembly	
Installation	4-37
Removal	4-34
Replacement	4-33
Testing	4-34
Equipment characteristics, capabilities, and features	1-1
Equipment data	1-4
Equipment description and data	1-1
Equipment dimensions	1-4
Equipment weight	1-4
Exhaust system	
Installation	4-32
Removal	4-31
Repair	4-31
Replacement	4-31
Expansion valve	
Installation	5-53
Removal	5-52
Replacement	5-50
Testing	5-51
Expendable/durable supplies and materials list	D-1

INDEX

SUBJECT	Page
Evaporator	
Installation	5-71
Removal	5-73
Replacement	5-70
F	
Fan, assembly	
Installation	4-25
Removal	4-25
Replacement	4-24
Filter-drier	
Installation	5-65
Removal	5-65
Replacement	5-64
Flywheel and ring gear assembly	
Assembly	4-78
Disassembly	4-75
Repair	4-75
Replacement	4-75
Foam precleaner	
Installation	4-40
Removal	4-40
Replacement	4-40
Service	3-2
G	
General information	1-1
General support maintenance	6-1

INDEX

SUBJECT	Page
H	
High pressure switch	
Installation	5-43
Removal	5-42
Replacement	5-41
Testing	4-79
High temperature thermal switch	
Installation	4-89
Removal	4-89
Replacement	4-88
Testing	4-89
Housing	
Installation	4-15
Removal	4-15
Repair	4-15
Replacement	4-14
I	
Inspection, unpacking and	4-3
Inspection	
Armature group	4-58
Pulley drive	4-24
Installation procedures	
Ball valve assembly	5-82
Carburetor	
Carrying handles	4-100
Compressor	5-57
Compressor cylinder head	5-61
Compressor discharge hose	5-41

INDEX

SUBJECT	Page
Installation procedures (cont)	
Compressor drivebelt	4-24
Compressor shaft seal	5-63
Compressor suction hose	5-39
Cylinder block, assembly	5-26
Cylinder heads	
Left	5-23
Right	5-20
Dipstick and tube assembly	4-68
Engine assembly	4-37
Exhaust system	4-32
Expansion valve	5-16
Fan assembly	4-25
Filter-drier	5-45
High pressure switch	5-43
High temperature thermal switch	4-89
Housing	4-15
Intake manifold assembly	4-49
Load binders	4-102
Low pressure switch	5-46
Low temperature thermal switch	5-85
Pressure relief valve	5-49
Spark plugs	4-57
Starter	4-73
Starter panel assembly	4-54
Thermostatic valve	5-78
Toggle switch So	4-21
Trailer mounting kit	5-86
Vehicle receptacle assembly	4-97
Water pump	4-85
Water pump drivebelt	4-22
Instructions, operating	
Intake manifold assembly	
Installation	4-49
Removal	4-48

L

Leak-testing refrigeration system	5-27
---	------

INDEX

SUBJECT	Page
Leak-testing water system	5-66
Location and description of major components	1-2
Low pressure switch	
Installation	5-46
Removal	5-45
Replacement	5-44
Testing	4-80
Low temperature thermal switch	
Installation	5-85
Removal	5-84
Replacement	5-84
Testing	4-93
Lubrication instructions	3-1
K	
Maintenance allocation chart	
Explanation of columns	B-3
Introduction (section I)	B-1
Maintenance allocation chart (sectionII)	B-4
Remarks (section IV)	B-11
Tool and test equipment requirements (section III)	B-10
Maintenance functions	B- 1
Maintenance forms, records, and reports	1-1
Maintenance procedures	
Operator	3-2
Organizational	4-13
Direct support	5-3
General support	6-1
Major components, location and description of	1-2
Major systems	1 - 5

INDEX

SUBJECT	Page
Modified mounting kit, trailer	5-89
Mounting kit, trailer	
Installation	5-86
O	
Operating procedure	2-6
Operation, Principles of	1-4
Operator maintenance	3-1
Operator preventive maintenance checks and services	2-3
Operator troubleshooting	3-1
Operator's controls and indicators, description and use of	2-1
Organizational maintenance	4-1
Organizational preventive maintenance checks and services	4-4
Organizational troubleshooting	4-10
Overhaul, cylinderblock assembly.	6-1

INDEX

SUBJECT	Page
P	
Paper cartridge	
Installation	4-40
Removal	4-40
Replacement	4-39
Service	3-4
Preparation for storage or shipment	4-102
Preventive Maintenance Checks and Services (PMCS)	
Operator	2-3
Organizational	4-4
Principles of operation	1-4
Procedures for Destruction of Equipment to Prevent Enemy Use, TM 750-244-3	1-1
Pulley drive	
Assembly	4-27
Disassembly	4-26
Inspection	4-24
Repair	4-26
Replacement	4-26
Q	
Quality Deficiency Report SF 368	1-1
R	
Recommended Changes to Equipment Technical Publications, DA Form 2028-2	i

INDEX

SUBJECT	Page
Recommended Changes to Publications, and Blank Forms, DA Form 2028	i
Refrigeration system	
Servicing	5-32
Charging	5-36
Discharging	5-32
Evacuation	5-34
Testing	
Leak-test	5-27
Electronic gas detector method	5-28
General instructions	5-28
Soap solution method	5-30
Pressure	5-30
Relief valve	
Adjustment	4-92
Assembly	4-91
Disassembly	4-90
Removal procedures	
Ball valve assembly	5-81
Carburetor	4-41
Carrying handles	4-35
Compressor	5-55
Compressor cylinder head and valve plate	5-60
Compressor discharge hose	5-41
Compressor drivebelt	4-23
Compressor shaft seal	5-63
Compressor suction hose	5-39
Cylinder block assembly	5-24
Cylinder heads	5-19
Dipstick and tube assembly	4-68
Engine, assembly	4-34
Evaporator	5-73
Exhaust system	4-31
Expansion valve	5-52
Fan assembly	4-25
Filter-drier	5-45
Foam precleaner	4-40
High pressure switch	5-42
High temperature thermal switch	4-87

INDEX

SUBJECT	Page
Removal procedures (cont)	
Housing	4-15
Intake manifold assembly	4-48
Low pressure switch	5-45
Low temperature thermal switch	5-84
Paper cartridge	4-40
Pressure relief valve	5-49
Spark plugs	4-57
Starter	4-71
Starter panel assembly	4-52
Thermostatic valve	5-77
Toggle switch S3	4-21
Vehicle receptacle assembly	4-95
Water pump	4-82
Water pump drivebdt	4-22
Repair procedures	
Armature group	4-58
Carburetor	5-4
Compressor	5-60
Cylinder block assembly	6-1
Dipstick and tube assembly	4-67
Exhaust system	4-31
Flywheel and ring gear assembly	4-75
Fuel hose	4-103
Housing	4-15
Pulley drive	4-24
Relief valve	4-90
Skid	4-99
Starter	5-13
Starter panel assembly	4-50
Support kit	4-101
Thermostatic valve	5-79
Trailer mounting kit	4-100
Water hose	4-103
Water pump	5-67
Wiring harness	4-18
Replacement procedures	
Armature group	4-58
Ball valve assembly	5-81

INDEX

SUBJECT	Page
Replacement procedures (cont)	
Carburetor	4-41
Compressor	5-55
Compressor discharge hose	5-40
Compressor drivebelt	4-23
Compressor suction hose	5-38
Cylinder block	5-23
Cylinder heads	5-19
Dipstick and tube assembly	4-67
Engine assembly	4-33
Evaporator	5-70
Exhaust system	4-31
Expansion valve	5-50
Filter-drier	5-44
Flywheel, and ring gear, assembly.	4-55
Fuel falter	4-103
High pressure switch	5-41
High temperature thermal switch	4-88
Intake manifold assembly	4-48
Low pressure switch	5-44
Low temperature thermal switch	5-84
Pressure relief valve	5-49
Pulley drive	4-26
Relief valve	5-74
Spark plugs	4-57
Starter	4-69
Starter panel assembly	4-50
Thermostatic valve	5-77
Toggle switch So	4-19
Vehicle receptacle, assembly.	4-94
Water pump	4-82
Water pump drivebelt	4-21
Reporting equipment improvement recommendations	1-1
Reporting errors and recommending improvements	i
S	
Scope	1-1

SUBJECT	Page
Servicing procedures	
Carburetor	5-9
Foam precleaned	3-2
Paper cartridge	3-3
Refrigeration system	5-32
Service upon receipt	4-3
SF 368, Quality Deficiency Report	1-1
Shipment instructions	4-104
Shutdown, automatic	2-26
Shutdown (standard)	2-26
Skid	
Preventive maintenance	2-13
Repair	4-99
Installation of carrying handle	4-100
Removal of carrying handle	4-99
Sparkplugs	
Adjustment	4-57
Installation	4-57
Preventive maintenance	4-8
Removal	4-57
Replacement	4-57
Starter	
Installation	4-73
Preventive maintenance	4-6
Removal	4-71
Repair	5-13
Replacement	4-69
Testing	4-69
Starter panel assembly	
Installation	4-54
Removal	4-52
Repair	4-50
Replacement	4-50
Testing	4-50

INDEX

SUBJECT	Page
Storage and shipment instructions	4-104
support kit	
Repair	4-102
Repair of fuel hose	4-103
Repair of water hose	4-103
Replacement of fuel filter	4-103
Systems, major	1-5
T	
Table of contents	i
Test Procedures	
Armature group	4-60
Engine assembly	4-33
High pressure switch	4-79
High temperature thermal switch	4-89
Low pressure switch	4-80
Low temperature thermal switch	4-93
Refrigeration system	
Leak	5-27
Pressure	5-30
Starter	4-67
Starter panel assembly	4-48
Wiring harness	4-18
Thermostatic valve	
Installation	5-78
Removal	5-77
Replacement	5-77
TM 750-244-3, Destruction of Army Materiel to Prevent Enemy Use	1-1
Toggle switch S3	
Installation	4-21
Removal	4-21
Replacement	4-19

INDEX

SUBJECT	Page
Trailer mounting kit	
Installation	5-86
Repair	4-101
Installation of load binders	4-102
Removal of load binders	4-101
Troubleshooting	
Direct support	5-2
Operator	3-1
Organizational	4-10
U	
Unpacking	4-3
V	
Vehicle receptacle assembly	
Installation	4-97
Removal	4-95
Replacement	4-94
W	
Water pump	
Installation	4-85
Removal	4-82
Repair	5-47
Replacement	4-82

INDEX

SUBJECT	Page
Water pump drivebelt	
Adjustment	4-22
Installation	4-22
Removal	4-22
Replacement	4-21
Weight, equipment	1-4
Wiring harness	
Repair	4-18
Test	4-18

By Order of the Secretary of the Army:

Official:

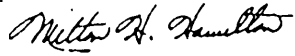

MILTON H. HAMILTON
*Administrative Assistant to the
Secretary of the Army*

01694

GORDON R. SULLIVAN
*General, United States Army
Chief of Staff*

DISTRIBUTION:

To be distributed in accordance with DA Form 12-25E, qty rqr block no. 2347.



THEN... JOT DOWN THE DOPE ABOUT IT ON THIS FORM. CAREFULLY TEAR IT OUT. FOLD IT AND DROP IT IN THE MAIL!

SOMETHING WRONG WITH THIS PUBLICATION?

FROM: (PRINT YOUR UNIT'S COMPLETE ADDRESS)

PFC JOHN DOE
COA, 3d ENGINEER BN
FT. LEONARDWOOD, MO 63108

DATE SENT

PUBLICATION NUMBER

TM 10-4130-237-14

PUBLICATION DATE

12 JUNE 1992

PUBLICATION TITLE

SMALL MOBILE WATER CHILLER

BE EXACT PIN-POINT WHERE IT IS

PAGE NO	PARA-GRAPH	FIGURE NO	TABLE NO
6	2-1 a		
B1		4-3	
125	line 20		

IN THIS SPACE TELL WHAT IS WRONG AND WHAT SHOULD BE DONE ABOUT IT:

In line 6 of paragraph 2-1a the manual states the engine has 6 Cylinders. The engine on my set only has 4 Cylinders. Change the manual to show 4 Cylinders.

Callout 16 on figure 4-3 is pointing at a bolt. In key to figure 4-3, item 16 is called a shim - Please correct one or the other.

I ordered a gasket, item 19 on figure B-16 by NSN 2 910-05-762-3001. I got a gasket but it doesn't fit. Supply says I got what I ordered, so the NSN is wrong. Please give me a good NSN

PRINTED NAME, GRADE OR TITLE, AND TELEPHONE NUMBER

JOHN DOE, PFC (268) 317.7111

SIGN HERE

JOHN DOE

DA FORM 2028-2
1 JUL 79

PREVIOUS EDITIONS ARE OBSOLETE.
DRSTS-M Overprint 1, 1 Nov 80

PS--IF YOUR OUTFIT WANTS TO KNOW ABOUT YOUR RECOMMENDATION MAKE A CARBON COPY OF THIS AND GIVE IT TO YOUR HEADQUARTERS

TEAR ALONG PERFORATED LINE

1 Nov 80

FILL IN YOUR
UNIT'S ADDRESS



FOLD BACK

DEPARTMENT OF THE ARMY

OFFICIAL BUSINESS

COMMANDER
U.S. ARMY TROOP SUPPORT COMMAND
ATTN: AMSTR-MMTS
4300 GOODFELLOW BOULEVARD
ST. LOUIS, MO 63120-1798

TEAR ALONG PERFORATED LINE

1 Nov 80

FILL IN YOUR
UNIT'S ADDRESS



FOLD BACK

DEPARTMENT OF THE ARMY

OFFICIAL BUSINESS

COMMANDER
U.S. ARMY TROOP SUPPORT COMMAND
ATTN: AMSTR-MMTS
4300 GOODFELLOW BOULEVARD
ST. LOUIS, MO 63120-1798

TEAR ALONG PERFORATED LINE

RECOMMENDED CHANGES TO EQUIPMENT TECHNICAL PUBLICATIONS

SOMETHING WRONG WITH THIS PUBLICATION?



THEN... JOT DOWN THE DOPE ABOUT IT ON THIS FORM. CAREFULLY TEAR IT OUT. FOLD IT AND DROP IT IN THE MAIL!

FROM: (PRINT YOUR UNIT'S COMPLETE ADDRESS)

DATE SENT

PUBLICATION NUMBER

TM 10-4130-237-14

PUBLICATION DATE

12 JUNE 1992

PUBLICATION TITLE

SMALL MOBILE WATER CHILLER

BE EXACT PIN-POINT WHERE IT IS

PAGE NO	PARA-GRAPH	FIGURE NO	TABLE NO

IN THIS SPACE TELL WHAT IS WRONG AND WHAT SHOULD BE DONE ABOUT IT:

TEAR ALONG PERFORATED LINE

PRINTED NAME, GRADE OR TITLE AND TELEPHONE NUMBER

SIGN HERE

DA FORM 2028-2
1 JUL 79

PREVIOUS EDITIONS ARE OBSOLETE.
DRSTS-M Overprint 2, 1 Nov 88.

P.S.--IF YOUR OUTFIT WANTS TO KNOW ABOUT YOUR RECOMMENDATION MAKE A CARBON COPY OF THIS AND GIVE IT TO YOUR HEADQUARTERS

1 Nov 80

FILL IN YOUR
UNIT'S ADDRESS



FOLD BACK

DEPARTMENT OF THE ARMY



OFFICIAL BUSINESS

COMMANDER
U.S. ARMY TROOP SUPPORT COMMAND
ATTN: AMSTR-MMTS
4300 GOODFELLOW BOULEVARD
ST. LOUIS, MO 63120-1798

TEAR ALONG PERFORATED LINE

RECOMMENDED CHANGES TO EQUIPMENT TECHNICAL PUBLICATIONS



THEN... JOT DOWN THE DOPE ABOUT IT ON THIS FORM. CAREFULLY TEAR IT OUT. FOLD IT AND DROP IT IN THE MAIL!

SOMETHING WRONG WITH THIS PUBLICATION?

FROM: (PRINT YOUR UNIT'S COMPLETE ADDRESS)

DATE SENT

PUBLICATION NUMBER

TM 10-4130-237-14

PUBLICATION DATE

12 JUNE 1992

PUBLICATION TITLE

SMALL MOBILE WATER CHILLER

BE EXACT PIN-POINT WHERE IT IS

PAGE NO	PARA-GRAPH	FIGURE NO	TABLE NO
---------	------------	-----------	----------

IN THIS SPACE TELL WHAT IS WRONG AND WHAT SHOULD BE DONE ABOUT IT:

TEAR ALONG PERFORATED LINE

PRINTED NAME, GRADE OR TITLE AND TELEPHONE NUMBER

SIGN HERE

DA FORM 2028-2
1 JUL 79

PREVIOUS EDITIONS ARE OBSOLETE.
DRSTS-M Overprint 2, 1 Nov 80.

P.S.--IF YOUR OUTFIT WANTS TO KNOW ABOUT YOUR RECOMMENDATION MAKE A CARBON COPY OF THIS AND GIVE IT TO YOUR HEADQUARTERS

1 Nov 80

FILL IN YOUR
UNIT'S ADDRESS



FOLD BACK

DEPARTMENT OF THE ARMY

OFFICIAL BUSINESS

COMMANDER
U.S. ARMY TROOP SUPPORT COMMAND
ATTN: AMSTR-MMTS
4300 GOODFELLOW BOULEVARD
ST. LOUIS, MO 63120-1798

TEAR ALONG PERFORATED LINE

The Metric System and Equivalents

Linear Measure

1 centimeter = 10 millimeters = .39 inch
 1 decimeter = 10 centimeters = 3.94 inches
 1 meter = 10 decimeters = 39.37 inches
 1 dekameter = 10 meters = 32.8 feet
 1 hectometer = 10 dekameters = 328.08 feet
 1 kilometer = 10 hectometers = 3,280.8 feet

Weights

1 centigram = 10 milligrams = .15 grain
 1 decigram = 10 centigrams = 1.54 grains
 1 gram = 10 decigrams = .035 ounce
 1 dekagram = 10 grams = .35 ounce
 1 hectogram = 10 dekagrams = 3.52 ounces
 1 kilogram = 10 hectograms = 2.2 pounds
 1 quintal = 100 kilograms = 220.46 pounds
 1 metric ton = 10 quintals = 1.1 short tons

Liquid Measure

1 centiliter = 10 milliliters = .34 fl. ounce
 1 deciliter = 10 centiliters = 3.38 fl. ounces
 1 liter = 10 deciliters = 33.81 fl. ounces
 1 dekaliter = 10 liters = 2.64 gallons
 1 hectoliter = 10 dekaliters = 26.42 gallons
 1 kiloliter = 10 hectoliters = 264.18 gallons

Square Measure

1 sq. centimeter = 100 sq. millimeters = .155 sq. inch
 1 sq. decimeter = 100 sq. centimeters = 15.5 sq. inches
 1 sq. meter (centare) = 100 sq. decimeters = 10.76 sq. feet
 1 sq. dekameter (are) = 100 sq. meters = 1,076.4 sq. feet
 1 sq. hectometer (hectare) = 100 sq. dekameters = 2.47 acres
 1 sq. kilometer = 100 sq. hectometers = .386 sq. mile

Cubic Measure

1 cu. centimeter = 1000 cu. millimeters = .06 cu. inch
 1 cu. decimeter = 1000 cu. centimeters = 61.02 cu. inches
 1 cu. meter = 1000 cu. decimeters = 35.31 cu. feet

Approximate Conversion Factors

To change	To	Multiply by	To change	To	Multiply by
inches	centimeters	2.540	ounce-inches	newton-meters	.007062
feet	meters	.305	centimeters	inches	.394
yards	meters	.914	meters	feet	3.280
miles	kilometers	1.609	meters	yards	1.094
square inches	square centimeters	6.451	kilometers	miles	.621
square feet	square meters	.093	square centimeters	square inches	.155
square yards	square meters	.836	square meters	square feet	10.764
square miles	square kilometers	2.590	square meters	square yards	1.196
acres	square hectometers	.405	square kilometers	square miles	.386
cubic feet	cubic meters	.028	square hectometers	acres	2.471
cubic yards	cubic meters	.765	cubic meters	cubic feet	35.315
fluid ounces	milliliters	29.573	cubic meters	cubic yards	1.308
pints	liters	.473	milliliters	fluid ounces	.034
quarts	liters	.946	liters	pints	2.113
gallons	liters	3.785	liters	quarts	1.057
ounces	grams	28.349	liters	gallons	.264
pounds	kilograms	.454	grams	ounces	.035
short tons	metric tons	.907	kilograms	pounds	2.205
pound-feet	newton-meters	1.356	metric tons	short tons	1.102
pound-inches	newton-meters	.11296			

Temperature (Exact)

°F Fahrenheit temperature 5/9 (after subtracting 32) Celsius temperature °C

